









# Nidec

## SRM-1624

### Mini Portable Slab Roller Operation Manual

#### For Your Safety

⚠ Caution			
	Place the slab roller on a flat surface.		Do not operate with more than 2 people.
	This is not a toy. Children should not operate.		Make sure the handle is secured properly in place before using.
	Do not disassemble.		Do not use with extremely stiff clay or any other materials.
	Do not put your hands in or near the following parts when in operation; rollers, roller adjustment area and canvas.	While operating the slab roller be carefull not to get your hands or clothes caught in the rollers. 	

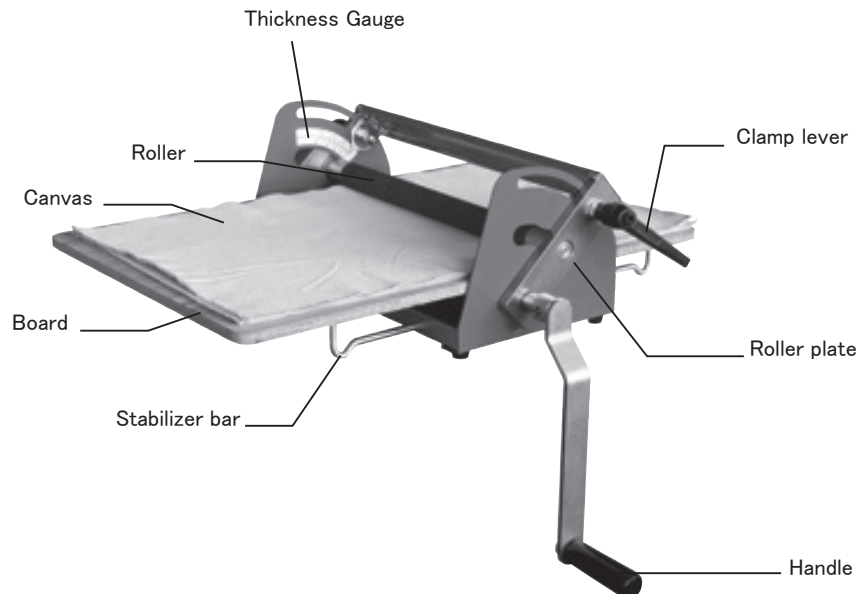

**NIDEC-SHIMPO CORPORATION**

**1. How to set up the portable mini slab roller**

1.1 Pull out the metal stabilizer bars on both sides of the roller assembly.

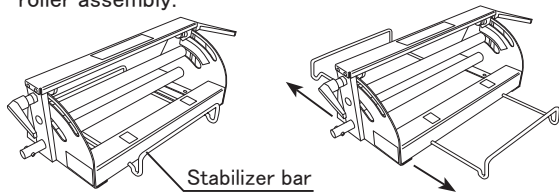

**2. To adjust the thickness of the clay**

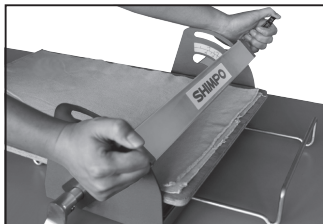

2.1. Pull up on the clamp levers to release the lock on the rollers.

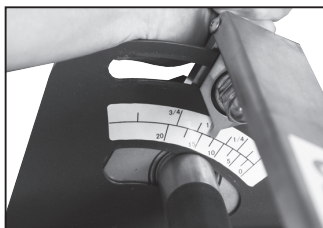

2.2. Set the rollers to the desired thickness of clay by sliding the rollers up or down, following the thickness gauge on the inside of the roller assembly.

**\*\*Attention: The thickness gauge is just an approximation of thickness.**

**3. How to prepare your slab roller to make a clay slab**

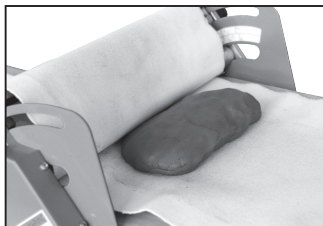

3.1. Place one canvas on the board. Then place the board, with the canvas, on the left side of the rollers just between the rollers.

3.2. Place a "cheese wedge shape" piece of well-mixed, soft, clay on the canvas covered board. The clay should not exceed 1-1/2" in height. The clay should not exceed the height of the top roller.

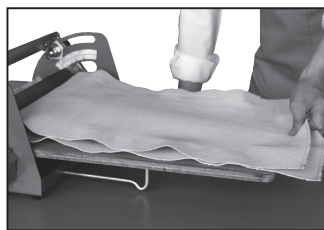
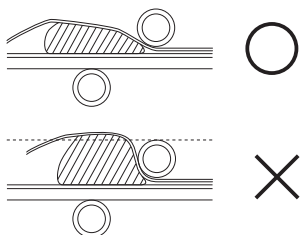

3.3. Place the second canvas on top of the clay.

**4. Install the handle into the roller assembly**

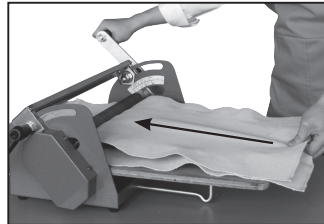

4.1. Turn the handle clockwise while guiding the board through the rollers in the direction of the arrow.

**5. To finish the slab**

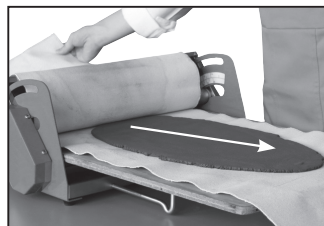

5.1. Once the board has been completely rolled through the rollers and is on the right side, roll the board back through (rotating handle counter-clockwise) so that it is on the left side again. This means the clay will be rolled through the rollers twice.

5.2. Remove the top canvas to reveal a completed slab.

**\*\*\*Do not use sharp tools when cutting clay on the canvas, this can damage the canvas.**



**Caution in using Portable slab roller**

- \*\*\*Do not overload the slab roller with a lot of clay at once, this can cause damage to the slab roller.
- \*\*\*Clean any leftover clay from canvas.

