



CENTURIONPRO

ELITE TRIMMING TECHNOLOGIES



OWNERS MANUAL

THE TABLETOP



IMPORTANT SAFETY INFORMATION

CENTURIONPRO SOLUTIONS: TABLETOP AUTOMATED TRIMMING SYSTEM

The TableTop is a high-speed trimming system, requiring that specific safety precautions are practiced during operation to reduce the risk of personal injury. Improper use of The TableTop, or any CenturionPro product, may cause serious or fatal injury. Please ensure you read the operations manual and warning notes before using the TableTop.

**DO NOT LEND OUT OR RENT YOUR TABLETOP WITHOUT THIS OPERATING MANUAL.
A FIRST TIME USER SHOULD OBTAIN PROPER INSTRUCTION PRIOR TO USE.**

GENERAL

- Do not move, disassemble, clean or inspect the trimmer while the power is still connected to the machine.
- Replacement parts are specific to The TableTop and must be purchased from an authorized dealer only. Substituting factory parts with non-approved third-party replacements may result in damage to the machine or bodily harm.
- Keep all individuals a safe distance from the work area. Do not operate the machine around children.
- Do not remove safety labels. Replace any and all labels if they become damaged or obscured.

CONNECTION

- As with home appliances, The TableTop must be used in connection with a properly grounded receptacle.
- Never plug in or power up your trimming machine if the protective shrouds are removed.
- Do not use extension cords over 8m (25ft) in length to power the TableTop.

OPERATION

- The initial set up will show assembly instructions to unpack and set-up your machine.
- Your bed bar blade has been factory set to cut perfectly. Please do not adjust your blade until it is time to clean the machine. Also, please watch the video tutorial located on our website on how to adjust your blade before attempting.
- Safety glasses should be worn at all times while operating The TableTop.
- Do not operate any trimming machine while tired or under the influence of medication, drugs or alcohol.
- Do not put anything other than plant material into the tumbler. Doing so may cause damage to the tumbler, the machine or result in bodily harm.
- Operate the trimmer in a well ventilated area in order to prevent overheating.

MAINTENANCE

- Never leave The TableTop system running unattended.
- Never conduct maintenance or cleaning while the machine is plugged in.
- Do not modify or adapt any part of the trimmer or its accessories. Doing so may cause irreversible damage to the machine or result in bodily harm.



TABLE OF CONTENTS

IMPORTANT SAFETY INFORMATION	2
TABLE OF CONTENTS	3
COMPONENT OVERVIEW	4
MACHINE ASSEMBLY	5
LEAF COLLECTOR ASSEMBLY	6
TRIPLE BAG KIEF COLLECTION SYSTEM	6
HOPPER ASSEMBLY	7
CLEANING & MAINTENANCE - BLADE REMOVAL, TRIMMER CLEANING	8
CLEANING & MAINTENANCE - LEAF COLLECTOR CLEANING	9
MACHINE MAINTENANCE	10
QUANTANIUM COATED TUMBLERS	11
TROUBLESHOOTING	12
FREQUENTLY ASKED QUESTIONS	14
ADDITIONAL ASSISTANCE	14
SPECIFICATIONS	15
WARRANTY	16
NOTES	17

TOOL REQUIREMENTS

AMOUNT	SIZE	TOOL ITEM
1 x	#2	PHILLIPS SCREWDRIVER
1 x	3/32"	T-Handle Allen Wrench
1 x	5/32"	T-Handle Allen Wrench
1 x	9/64"	T-Handle Allen Wrench
1 x	1/8"	T-Handle Allen Wrench
1 x	3/16"	T-Handle Allen Wrench
1 x	3/8"	Wrench

COMPONENT OVERVIEW

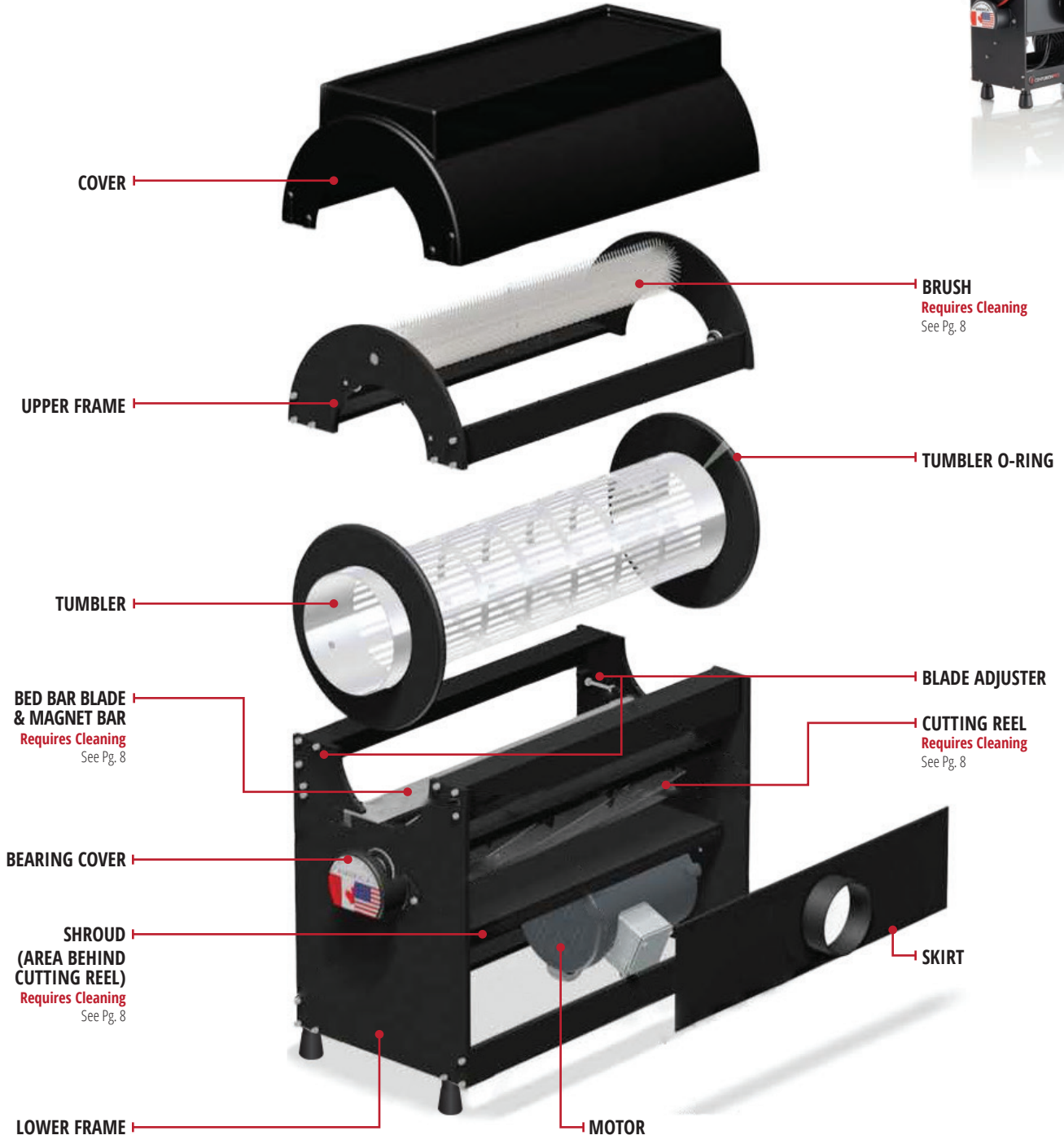

110V North America
220V Australia EU

MACHINE ASSEMBLY

STEP 1: PLACE TUMBLER IN GROOVES

Note: longer end of Tumbler should be installed on the side that faces the hopper.



STEP 2: INSTALL UPPER FRAME

Tighten four sealing bolts & washers.



STEP 3: INSTALL COVER

Place cover over Upper Frame.



STEP 4: INSTALL SKIRT

Note: installed on the machine when shipped.



NOTE: the longer end of the TUMBLER when re-installing



STEP 5: INSTALL BEARING COVER TO THE TABLETOP

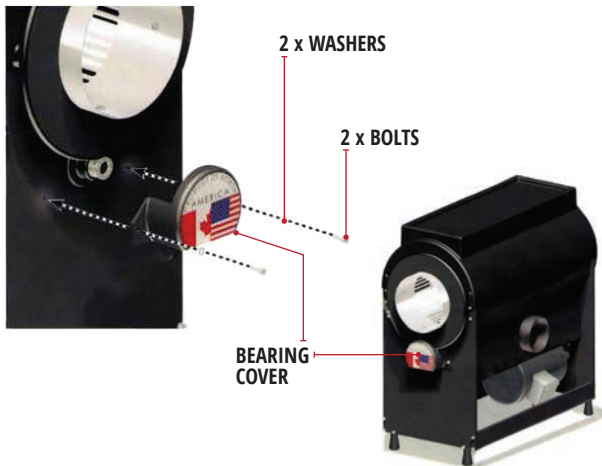

STEP 6: INSTALL BELT COVER TO THE TABLETOP

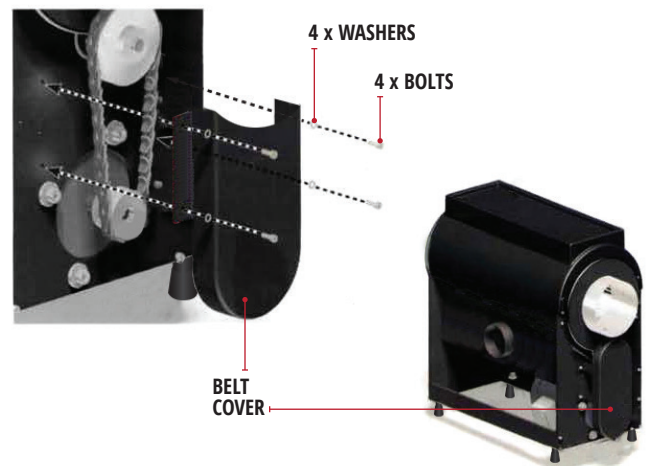

IT IS UNSAFE TO OPERATE THE TABLETOP TRIMMER WITHOUT COVERS.

LEAF COLLECTOR ASSEMBLY

STEP 1: ATTACH BAG SYSTEM TO LEAF COLLECTOR

- Secure with 5" hose clamp
- Requires cleaning (pg. 9)



Please disregard hole on top of diverter, the suction will hold the diverter in place and no screw is needed to secure.



STEP 2: ATTACH 5" FLEX HOSE TO THE DIVERTER & TABLETOP

- Secure with 5" hose clamp

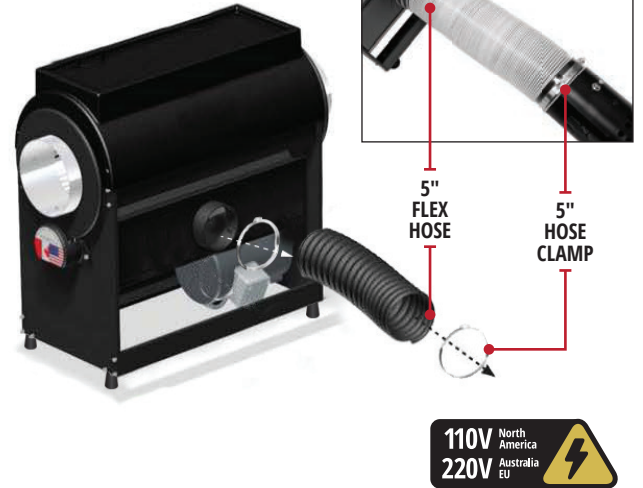

TRIPLE-BAG KIEF COLLECTION SYSTEM

Kief is becoming wildly popular due to the rise of extractions. Unfortunately, machines that require sprays can contaminate and destroy your Kief, making it virtually useless. Thankfully, CenturionPro offers an optional non-stick Quantanium coating on the tumblers. This means no spray is needed, so your Kief remains 100% pure and usable. To further benefit growers, we developed a new triple-bag filtration system. This system will assist with Kief collection and separating it from your trim. This allows you to safely and easily collect the precious trichomes for further processing and profits. With your machine, you will see that you have a black mesh bag, a white nylon bag, and an outer cloth bag. The black bag goes inside the white nylon bag, which then goes inside the white cloth bag.

THE BAGS ARE EASY TO WASH WITH A PRESSURE WASHER USING COLD WATER. THE BAGS CAN ALSO BE PUT THROUGH THE WASHING MACHINE, BUT IT IS RECOMMENDED TO BE RUN THROUGH ON A COLD DELICATE CYCLE ONLY.



HOW IT WORKS

- | | |
|---------------|---|
| STEP 1 | THE GREEN LEAFY TRIM WILL COLLECT IN THE INNER BLACK BAG. |
| STEP 2 | ONLY THE KIEF MAKES IT THROUGH THE BLACK BAG AND COLLECTS IN THE OUTER MESH BAG. |
| STEP 3 | OUTER CLOTH BAG CATCHES ANY KIEF THAT MAY PASS THROUGH THE MICRON WHITE BAG. |
| STEP 4 | TURN OFF THE MACHINE AND REMOVE THE INNER BAGS AND THEN EXTRACT KIEF. ENJOY! |



HOPPER ASSEMBLY

STEP 1: ASSEMBLE FRAME

- A) Ensure the RODS are facing inward. Secure with:
8 - 1/4" bolts
8 - 1/4" washers
8 - 1/4" locking nuts

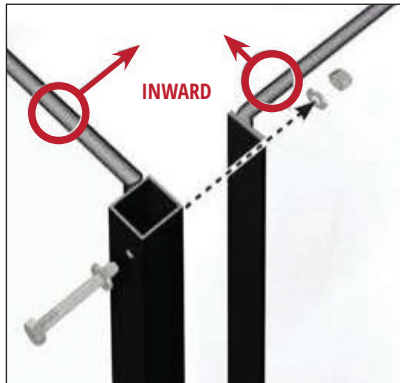

STEP 2: SECURE HOPPER BAG TO FRAME

- A) Ensure the FRAME & OPENING match.

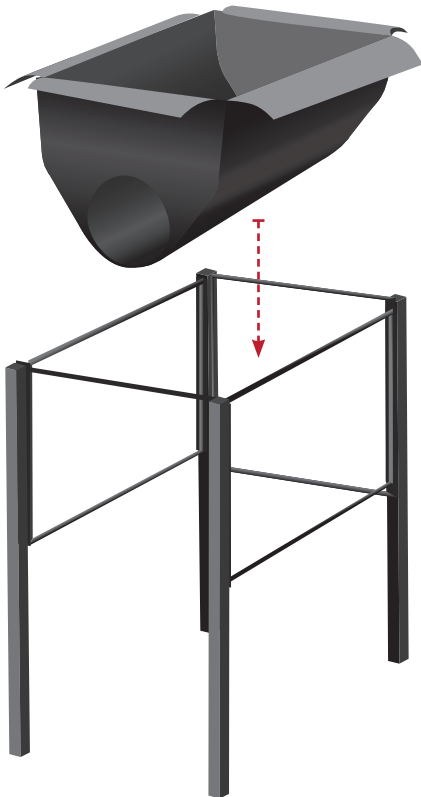

STEP 3: CONNECT THE HOPPER TO THE MACHINE

- A) Ensure the FRAME & OPENING match the TableTop machine exactly.

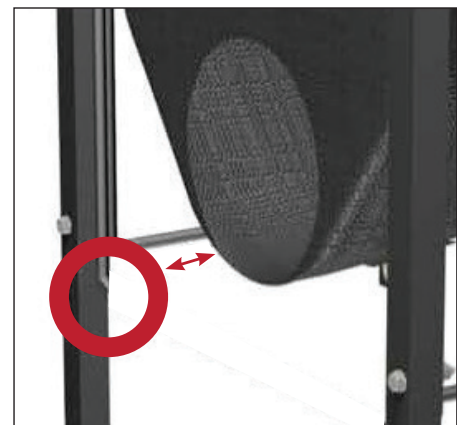
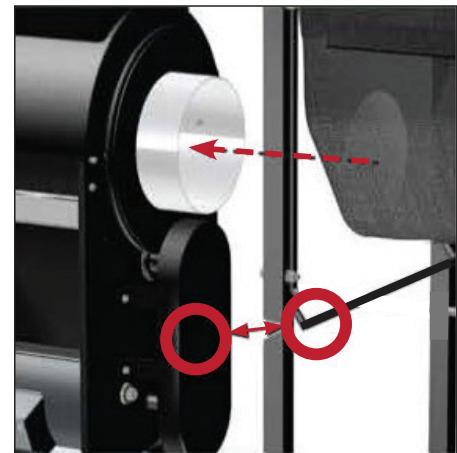

BLADE REMOVAL

For optimal performance and life, the BLADE and the MAGNET BAR must be removed and cleaned every 3-4 hours of operation.

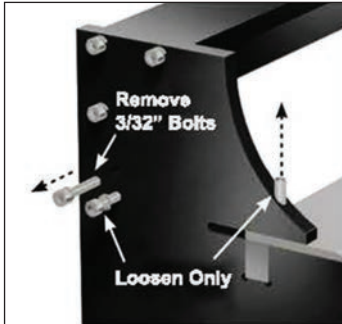

STEP 1: UNLOCK BLADE

- Remove 3/32" bolt
- Loosen the surrounding set screws ONLY



STEP 2: UNPIN BLADE

- Pivot the pin up from the blade

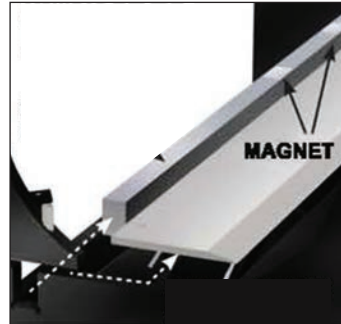

STEP 3: BLADE & MAGNET REMOVAL

- Carefully slide blade off magnets
- Carefully Remove bed bar blade

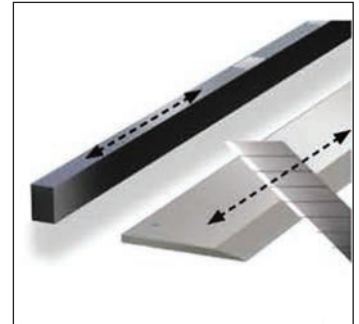

STEP 4: BLADE & MAGNET CLEANING

- Clean blade and magnet bar with a utility knife.

INSTALLATION IS REVERSE ORDER OF REMOVAL



IMPORTANT NOTE:

YOUR BED BAR BLADE HAS BEEN FACTORY SET TO CUT PERFECTLY. PLEASE DO NOT ALTER THE SETTINGS OF YOUR MACHINE. YOU MIGHT NOTICE SLIGHT CONTACT BETWEEN YOUR ROTATING CUTTING REEL AND THE FLAT BED BAR BLADE - THIS IS NORMAL.

CLEANING THE TABLETOP TRIMMER

For optimal performance and life, the components must be cleaned every day after use.

STEP 1: CLEAN BRUSH

Clean the length of the brush of all debris using hot pressurized water.



STEP 2: CLEAN ELECTROPLISH TUMBLER

Clean the length of the tumbler of all debris using hot pressurized water.

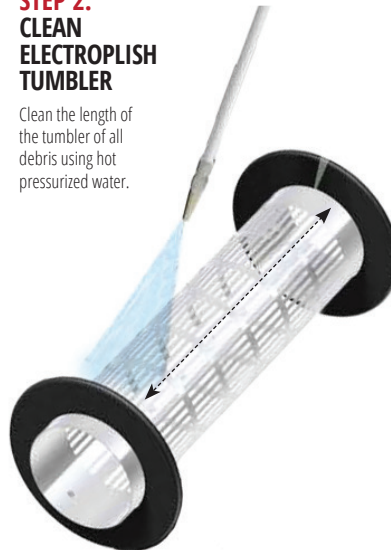

STEP 3: CLEAN CUTTING REEL & SHROUD

Clean the length of the cutting reel and shroud of all debris using hot pressurized water.

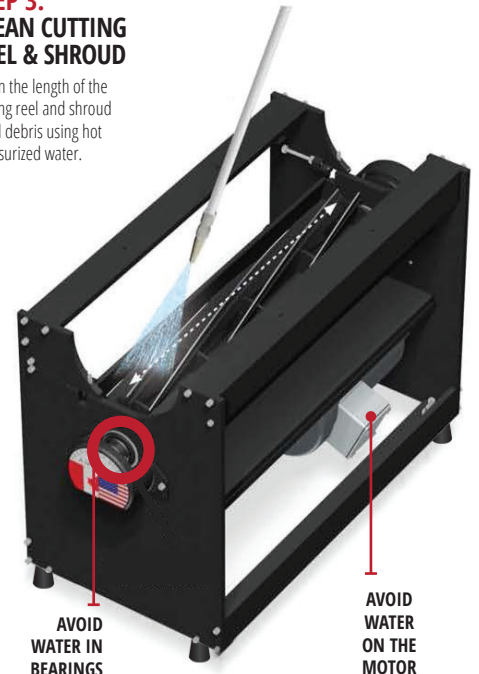

AVOID WATER IN BEARINGS

AVOID WATER ON THE MOTOR



IMPORTANT NOTE:

- Clean with pressure-washer at 1500 - 2000 psi.
- Hot water, fan spray setting
- Run TableTop for 15 mins after washing to allow components to dry
- DO NOT pressure-wash Quantanium Coated tumblers (see page. 10)

LEAF COLLECTOR CLEANING

STEP 1: REMOVE COVER & IMPELLER FROM LEAF COLLECTOR

- Remove 8 screws from the side panel to uncover the leaf collector
- Remove the 13mm bolt & washer located in the middle of the fan blades
- When removing the blower impeller, use a pulling tool only.



ONLY USE PULLING TOOL WHEN REMOVING THE BLOWER IMPELLER FOR CLEANING. CLEAN BLOWER EVERY 30-40 DAYS OF USE.



STEP 2: PRESSURE WASH IMPELLER & INTERIOR OF LEAF COLLECTOR

- Spray the impeller blades with your pressure washer using hot water
- Tip the leaf collector up so that the opening is in a drain position
- Spray the entire inside of the leaf collector. Avoid spraying directly onto the bearing
- To clean the outside of the unit, wipe the leaf collector down with some isopropyl alcohol to remove dirt and residue

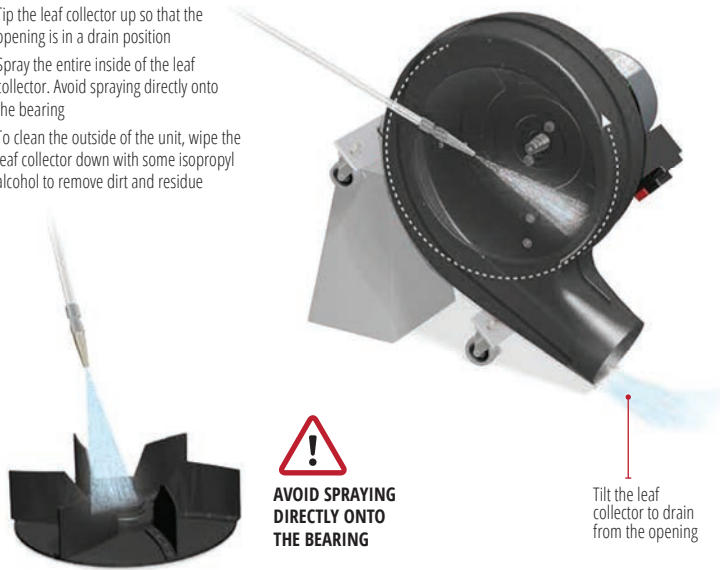

AVOID SPRAYING DIRECTLY ONTO THE BEARING

Tilt the leaf collector to drain from the opening

STEP 3: CLEAN LEAF COLLECTOR BAGS

- Unzip all three bags to empty contents
- Turn leaf collector bags inside-out separately and pressure wash each bag
- Allow bags to dry

Black Mesh Bag

White Filter Bag

Outer Polyester Bag



Turn inside-out to pressure wash and let dry.

****INSTALLATION IS REVERSE ORDER OF REMOVAL**

INSTRUCTIONS:

Clean with pressure-washer at 1500 - 2000 PSI, Hot Water, Fan Spray Setting. Run LEAF COLLECTOR for 15 minutes after washing, allowing components to dry.

**30
DAYS**

FOR OPTIMAL PERFORMANCE AND LIFE, THE LEAF COLLECTOR COMPONENTS MUST BE CLEANED EVERY 30 DAYS OF USE.



AVOID WATER CONTACT ON BEARINGS AND MOTOR.

MACHINE MAINTENANCE

The Tabletops are precision machines. It is essential that they be operated and maintained with this in mind. The machine has been adjusted and tested by the manufacturer prior to shipping to ensure optimal performance. However, it is important to inspect the machine at initial start-up and after each use to ensure that no damage or plant material build-up has occurred and that the blades spin freely.

In addition, it is highly recommended to clean the machine at the end of every use. This ensures that the blades are kept lubricated and that resin does not build-up and affect performance. This is especially important if the machine has been stored for an extended period of time.

If optional Quantanium coating is chosen, the machine will not require any lubricants or sprays. The application of which will only damage or alter the final product and will not assist with the cutting process. In fact, it may hinder it. Cold water is recommended to spray on blades during harvest.

TRIM BOTH WET + DRY



**ELECTROPOLISHED
DUAL-PURPOSE
HYBRID TUMBLER**



CENTURIONPRO DUAL-PURPOSE HYBRID TUMBLER

DESIGNED FOR BOTH WET + DRY TRIMMING

All CenturionPro trimming machines are specially designed to trim both wet and dry material better than any other machine on the market. Our Dual-Purpose Hybrid Tumbler has been extensively tested to outperform both the traditional wet tumbler when trimming wet and the traditional dry tumbler when trimming dry.

This CenturionPro innovation allows you to switch between wet and dry material with just a few small adjustments to your trimming system. This is a major benefit because you can purchase one machine and still have the capability to trim wet or dry flowers.

See our dry trimming tips below for more details.

TRIMMING DRY? HERE ARE SOME IMPORTANT TIPS!

- Begin by hanging the entire plant, leaving the leaf on. Starting with 30% humidity at 60-65 degrees Fahrenheit for 24 hours, raising the humidity to 50-60% for another five to six days.
- Next, carefully cut all your flowers off the main stocks of the plant, leaving only flowers and leaves in tact. Then, depending on the density of the flowers, it should be ready to run through the machine.
- The buds should be about 80-90% dry, which allow the fan leaf and sugar leaf to remain somewhat PLIABLE/BENDY, in a soft and flexible state. If the larger leaf is too dry and brittle (which makes it more difficult for the machine to pull this stiffer leaf through the slots of the drum, preventing a clean, sharp cut) raise the humidity up to 75% for about half a day to a full day. This, remarkably, softens up the unwanted leaf while returning almost no additional moisture to the main body of the buds.

CRITICAL:

IT IS CRITICAL FOR THE UNWANTED LEAVES TO BE **SOFT AND BENDY** FOR THIS MACHINE TO PERFORM A CLEAN PERFECT CUT. WE ALSO RECOMMEND USING A **HUMIDIFIER OR A WATER BOTTLE WITH A MISTING NOZZLE** TO RE-INTRODUCE A SMALL AMOUNT OF MOISTURE TO THE UNWANTED LEAVES BEFORE RUNNING THE FLOWERS THROUGH THE MACHINE.

NOTE 1:

THIS METHOD WILL ALLOW VIRTUALLY NO ADDITIONAL MOISTURE BACK TO THE INNER BUD/FLOWER. THE MOISTURE WILL ONLY SOFTEN UP THE OUTER LEAVES.

NOTE 2:

THE LEAVES MUST BE SOFT AND PLIABLE FOR THE DRY TRIMMER TO BE EFFECTIVE.

After running the buds through the machine the chances are they are ready to bag up! All that might be necessary is a quick test after the bag has been sealed by opening it back up to air them out a bit to achieve the perfect moisture content (curing process). You may prefer to run the machine with the plastic cover off, and diverter almost open (this varies depending on the density of the strain). Please note the machine operates best when the tumbler is 40-60% full. A huge bonus to the DRY trimming method is that the machine will require almost no periodic cleaning, as the tumblers and blades will not gum up and therefore not reduce performance. The main advantage of DRY trimming is said to be better preservation of all the strong natural aromas and flavours after the harvesting process is complete.

MONTHS OF WORK CAN BE RUINED IN A FEW HOURS AT THE END SO PLEASE BE PATIENT AND TAKE YOUR TIME WITH THE HARVESTING AND CURING PROCESS.

QUANTANIUM COATED NON-STICK TUMBLER

WHAT IS QUANTANIUM?

Quantanium is a multi-coat non-stick coating that incorporates a unique mix of titanium particles. These particles are blended into the coating that stands up to almost anything and makes the tumbler resistant to scratching. The outstanding release is provided by silicone, not PTFE. All of our Quantanium coated tumblers are made without PTFE/PFOA.

WHY DO WE USE QUANTANIUM?

HIGHER POTENCY HARVEST

The non-stick properties of the Quantanium tumbler prevents precious trichomes from adhering the tumbler surface without the need for sprays. This results in the end product having a better visual appearance while maintaining its strong natural aroma and flavors. Overall, this results in a better-quality end product as the natural properties are preserved during the harvesting and trimming processes.

SAVE TIME = SAVE MONEY

Another benefit of the Quantanium tumbler is that it speeds up the harvesting process since no downtime is required to stop and clean the tumblers throughout the day. A simple wipe down with a cloth and warm water will remove the small amount of residue that may be present.

HOW TO CLEAN THE QUANTANIUM TUMBLER

When cleaning the Quantanium tumbler, we recommend that you DO NOT pressure wash it. This will cause the coating to flake and come off. Treat the tumbler the same way you would treat a non-stick pan at home by letting it soak in warm, soapy water. After letting it soak, rinse the tumbler and then wipe it with a soft, clean cloth.

In extreme cases, residue can be removed by a thorough cleaning with 3 TBSP of vinegar, 1 TBSP liquid dish detergent and 1 cup of water. Apply with sponge or plastic scrubbing pad, then completely rinse with warm water.

DO NOT USE AUTOMOTIVE DEGREASERS.

While the Quantanium surface is designed to stand up to rough treatment, non-stick surfaces last longer if you are careful not to rub or touch them with metal surfaces or sharp objects. Remember that sensible care of your Quantanium tumbler will ensure it lasts for many years.



QUANTANIUM COATED
DUAL-PURPOSE
HYBRID TUMBLER



IMPORTANT NOTE:

- DO NOT PRESSURE WASH
- SOAK IN WARM SOAPY WATER, RINSE & WIPE

TROUBLESHOOTING



MY PRODUCT IS STUCK IN THE MIDDLE OF MY TUMBLER AND WILL NOT COME OUT THE OTHER END.

- 1) The tumbler should always be 40%-60% full. You should be feeding the tumbler every 30-60 seconds; this will ensure that new product entering the machine will help push out product that is trimmed. This constant flow of product will also help with your processing capacity.
- 2) You can also increase the downward slope of the machine. To do this place a piece of cardboard or wood underneath the input side wheels/legs. Before turning the machine ensure that the machine is level and sturdy.
- 3) Try opening the Diverter fully and/or removing the plastic top cover. This will increase the air flow and decrease the suction, allowing product to pass through quicker.



MY LEAF COLLECTOR IS NOT TURNING ON.

- 1) Ensure the correct voltage is being supplied as per your manual and never use an extension cord longer than 25 ft. Using an extension longer than 25 ft long will cause a drop in power being supplied to the leaf collector. This can cause the motor to compensate for the lost power, therefore over heat and eventually burn out.
- 2) Test your electrical current to make sure it is producing power. We recommend having a certified electrician set up the proper power supply as noted on pg. 15. This will ensure your power source is supplying the correct electricity. If you have not done this, have a certified electrician come and test your electrical current.
- 3) If you have tried all of the above, then your leaf collector's capacitors or electrical box may need to be replaced. Ensure that you have a certified electrician install the parts correctly. Also have them double check your power supply. If your power supply is inconsistent, the same problems will occur in the future.



MY TUMBLER IS SPINNING SLOWER THAN USUAL OR IS NOT SPINNING AT ALL.

- 1) You will need to take a link (or two) out of the belt. Use a pair of needle nose pliers to help you with this. When putting your tightened belt back on your machine it might be a little difficult. Use the video tutorial "Removing and Replacing the Belt" on our website to help you with this. Once the belt is tightened properly, the tumbler speed will resume back to normal.
- 2) Ensure that the tumbler is placed correctly in the grooves and there is no lubricant on the Tumbler O Rings (red o-rings on both sides of the tumbler). This will cause the tumbler to slip in one spot rather than make a full rotation.
- 3) Ensure your Cam Follower's O Rings are in tact. You should NEVER run your machine without these. Cam Followers help guide the tumbler, without these your tumbler and/or machine can incur damage.



THE LEAF COLLECTOR SUCTION SEEMS WEAK.

- 1) Ensure the correct voltage is being supplied as per your manual and never use an extension cord longer than 25 ft. Using an extension cord longer than 25 ft long will cause a drop in power being supplied to the leaf collector. This can cause the motor to compensate for the lost power, therefore over heat and eventually burn out.
- 2) Test your electrical current to make sure it is producing power. We recommend having a certified electrician set up the proper power supply as noted on pg. 15. This will ensure your power source is supplying the correct electricity. If you have not done this, have a certified electrician come and test your electrical current.
- 3) Ensure the leaf collector and surrounding parts are clean. Also ensure nothing is blocking the inlet or the outlet of the leaf collector. Often buildup of product around the openings of the blower can cause weak suction. Be sure to clean the Kief Collection System, Impeller and the inside of the blower. Refer to pg. 9 for cleaning instructions.



THE PRODUCT IS NOT COMING OUT TRIMMED.

- 1) First, ensure that your machine is clean. Clean the Bed Bar Blade (flat blade), top and underneath every 3-4 hours of use. The Reel Blade (rotary blade) should be cleaned every 6-8 hours of use. Think of the blades as a pair of scissors, if the blades are not clean the machine will not be able to do its job.
- 2) Secondly, ensure that the Bed Bar Blade is set close to the Reel Blade. The space between the two blades should be the same thickness as a single sheet of newspaper – essentially, they should be skimming. Please refer to the video tutorial "Adjusting the Blade" on our website on how to set the Bed Bar Blade accurately. Again, think of the blades as a pair of scissors, if the blades are too far away from each other they will not trim your product.
- 3) Lastly, ensure the suction from the Leaf Collector is working correctly. Make sure there are no air-leaks. Keep in mind that long extension cords result in a decrease in performance of the machine and its components.

MY MACHINE MOTOR IS HOT

- 1) Your machine may be overworking due to a voltage drop in your power supply. This can happen if you're using an extension cord that is too long or undersized. You can only use an extension cord with a maximum length of 25ft.
- 2) Use a voltage tester to test your electrical current to ensure you have the correct voltage. We recommend having a certified electrician come in and make sure your power supply is consistent.
- 3) Having a motor on for an extended period can be the reason for overheating. Allow the motor to cool down by turning the machine off for an hour, every 5 hours of use.

**MY LEAF COLLECTOR IS MAKING A LOUD BANGING NOISE**

- 1) Ensure your blower is clean of debris and build up. Build up inside the blower and on the impeller can cause contact with the housing of the blower.
- 2) If cleaning the build up in your blower does not stop the noise, there may be a bend in your impeller. As such, you will need to purchase a new impeller to replace the one in your leaf collector. To remove the impeller use ONLY a pulling tool. Refer to pg. 9 for instructions on how to properly remove the impeller.

**THE CIRCUIT BREAKER KEEPS TRIPPING.**

- 1) This is caused by a cord that is too long or undersized. Your cord must be no more than 25ft long and the same gauge of thickness as the main cord.
- 2) Also, ensure the machine is not sharing a circuit with other devices and the correct size breaker is present. Circuit sharing can significantly decrease the power being supplied to the devices therefore causing the breaker to trip.
- 3) Test your electrical current to make sure it is producing consistent power. We recommend having a certified electrician set up the proper power supply as noted on pg. 15. This will ensure your power source is supplying the correct electricity. If you have not done this, have a certified electrician come and test your electrical current to ensure it complies with the electrical requirements on pg. 15.

**THERE IS A HIGH-SPEED TICKING SOUND COMING FROM THE BLADES.**

- 1) The ticking sounds might be the bed bar blade and reel blade making slight contact. If the machine is producing a louder than usual ticking/banging sound, then turn off the machine and inspect the blades. Ensure your blades are properly adjusted by following the video tutorial "Adjusting the Bed Bar Blade" on our website.
- 2) A fin on the tumbler might be slightly protruding therefore causing slight contact with the bed bar blade. This will cause a ticking sound for every rotation the tumbler does. Watch the video tutorial on our website called "Straightening the Drum". Also ensure the blade is adjusted properly.

**MY TUMBLER IS HOPPING AND/OR WOBBLING.**

- 1) All tumblers are hand rolled and welded. None of our tumblers are cut from a perfectly cylindrical pipe, therefore the tumbler might appear as it is slightly wobbling while the machine is on.
- 2) You might notice a slight hop to your tumbler every rotation. This is from the Red Tumbler O Ring. This should not affect the functioning of your machine. However, if you notice the hop getting worse, you will need to replace this part.

**THERE IS A HIGH PITCH SCREECHING NOISE COMING FROM MY MACHINE.**

- 1) Determine if the noise is coming from your reel bearings or brush assembly. Check your reel bearings to ensure they are greased sufficiently, Take a look at the video tutorial "Packing the Bearings" on our website to help you with this. If the noise persists after you grease your bearings you will need to purchase and replace them. If the noise is coming from your brush assembly, you will need to purchase and replace the brush bearings.
- 2) If the noise is coming from your leaf collector, you will need to replace the bearings in your leaf collector. Please contact our tech support for more details on this.
- 3) It is very important to ensure that after cleaning your machine, you run it for 10-15 mins to ensure there is no residual water around the bearings.



FREQUENTLY ASKED QUESTIONS

HOW EASY IS IT TO CLEAN?

Our machines can be taken apart and cleaned within 15 minutes. Please see the detailed cleaning instructions throughout this manual. Our Quantanium coating is similar to a Teflon pan you would have at home which is even easier to clean. Just submerge in warm water, let soak and then wipe with a soft cloth. We recommend to clean every 3-4 hours of use, but it depends on your strain. We know the importance of down time during a harvest so we wanted to make this process extremely quick and easy

WHAT IS THE MAINTENANCE LIKE?

We have several video tutorials on our website with how to fully service your machine. These step by step DIY videos make it very easy to do everything necessary to maintain your machine. All parts can be ordered through any hydroponic store nationwide.

DO YOUR MACHINES TRIM WET OR DRY?

All CenturionPro trimming machines are specially designed to trim both wet and dry material better than any other machine on the market. Our Dual-Purpose Hybrid Tumbler has been extensively tested to outperform both the traditional wet tumbler when trimming wet and the traditional dry tumbler when trimming dry.

This CenturionPro innovation allows you to switch between wet and dry material with just a few small adjustments to your trimming system. This is a major benefit because you can purchase one machine and still have the capability to trim wet or dry flowers.

ARE YOUR MACHINES BUILT TO AN INDUSTRIAL STANDARD?

We do not compromise quality for cost savings. All CenturionPro Solutions machines are composed of the highest quality materials available in North America and each machine is put through a comprehensive quality control inspection. We only use brand name components in the build out of our machines which enables us to have the comfort in giving you a 10 year trimmer warranty. With proper maintenance these machines will last you well over a decade.

WHAT IS THE OPTIMAL ROOM TEMPERATURE TO TRIM?

Use your CenturionPro machine in 50-60 °F (10- 15 °C) room to get the best performance. Cooler temperatures prevent excessive sticking to machine components.

MY MACHINE IS NOT WORKING LIKE IT DID WHEN IT WAS NEW, WHY?

Make sure to fully clean the machine and blades. If the machine is clean, the blade is adjusted properly and the leaf collector has full suction, then your machine should trim exactly like it was new.

WHY IS MY PRODUCT STICKING TO THE INSIDE OF THE TUMBLER?

If you find that product is sticking to the inside of the tumbler, first clean the tumbler. When you reassemble it, make sure the top brush bristles are poking through 1/4" into the tumbler.

HOW MUCH PRODUCT SHOULD BE IN THE TUMBLER AT ONE TIME?

The tumbler should be 40-60% full when trimming.

ADDITIONAL ASSISTANCE

You are about to enjoy the experience of CenturionPro Solution's automated trimming machine. For critical information on assembly, cleaning, care, maintenance and how to operate your machine correctly, please review this manual and check out our video tutorials, which are posted on our website for your ease and convenience.

Go to www.cprosolutions.com/video-tutorials for our video tutorials.

These tutorials provide how-to assistance on the following aspects of machine maintenance:

• Straightening the Tumbler/Drum	• Complete Unit Assembly	• Sharpening The Blade
• Skirt Assembly	• Replacing the Bearings	• Cleaning The Blower
• Removing and Replacing The Belt	• Manually Bucking Your Product	• Adjusting The Blade
• Replacing The Motor	• Trimmer Cleaning and Maintenance	• Packing The Bearings
• Blade Removal and Cleaning	• Replacing The Tumbler/Drum Ring	• Replacing The Pulleys

****If for some reason you can't find an answer to your question online or in your manual, please do not hesitate to contact us.**

**WE ARE OPEN MONDAY THROUGH FRIDAY FROM 9AM TO 5PM PST - PH: 1-855-535-0558
 FILLING OUT THE "CONTACT US" FORM ON THE WEBSITE, IS ANOTHER SURE WAY TO GET IN TOUCH.**

TABLETOP & LEAF COLLECTOR SPECIFICATIONS

TABLETOP TRIMMER

Input Voltage	6 Amp - 110V NA
	3 Amp - 220V EU/AUS
Dimensions	24" L x 10" W x 21" H
Weight	40 lbs
Reels	1
Blades Per Reel	7
Tumbler Diameter	5.5"
Tumbler Length	24"
Number of Tumblers	2
Human Trimmer Replacement	16 people
Processing Capacity	Dry: 4 lbs/hr
	Wet: 20 lbs/hr
Cuts Per Minute	20,000
Warranty	10 year

TABLETOP LEAF COLLECTOR

Input Voltage	12 Amp - 110V NA
	6 Amp - 220V EU/AUS
Dimensions	16" L x 13.5" W x 13.5" H
Weight	20lbs
Horsepower	1 hp
Airflow Capacity	1800 CFM
Warranty	3 year

ELECTRICAL POWER SUPPLY SET-UP

TEST YOUR ELECTRICAL CURRENT TO MAKE SURE IT IS PRODUCING POWER. **WE RECOMMEND HAVING A CERTIFIED ELECTRICIAN SET UP THE PROPER POWER SUPPLY.** THIS WILL ENSURE YOUR POWER SOURCE IS SUPPLYING THE CORRECT ELECTRICITY. IF YOU HAVE NOT DONE THIS, HAVE A CERTIFIED ELECTRICIAN COME AND TEST YOUR ELECTRICAL CURRENT.



!! IMPORTANT !!

WARRANTY

YOU MUST REGISTER YOUR TRIMMER WITHIN 30 DAYS OF YOUR PURCHASE

YOU HAVE JUST MADE A SMART DECISION BY PURCHASING THE BEST TRIMMER IN THE WORLD. FAILURE TO REGISTER YOUR MACHINE WITHIN 30 DAYS OF PURCHASE WILL VOID YOUR 10 YEAR WARRANTY. PROTECT YOUR INVESTMENT. THIS PROCESS WILL ONLY TAKE 3 MINUTES TO COMPLETE.

TO REGISTER GO TO:

cprosolutions.com/warranty

WARRANTY TERMS AND CONDITIONS

CenturionPro Solutions (the manufacturer) will repair or replace, without charge, any parts proven defective in material or workmanship for a period of 10 years on the Trimming Machine and 3 years on the Leaf Collector.

The warranty period will begin on the date the machine(s) is purchased by the initial purchaser. Product or component warranty defects can be remedied at any authorized service dealer, or directly at the manufacturer. Any service work performed, and deemed valid due to a defective part, will be free of charge. CenturionPro Solutions reserves the right to use any manufacturer-approved replacement part for the warranty repair.

The machine or defective part then must be returned to the manufacturer for analysis or replacement at the cost of the owner. Parts deemed to be covered under the warranty will be provided for free excluding shipping costs.

Do not return the machine to the place of purchase for repair or warranty claims, unless you have been authorized by CenturionPro Solutions to do so. The place of purchase can only sell replacement parts and will not repair any warranty issues, unless it is noted as an authorized repair dealer and has been authorized to work on your machine.

IF WARRANTY REPAIR IS REQUIRED, PLEASE CONTACT THE MANUFACTURER AT 1-855-535-0558 OR techsupport@cprosolutions.com AND PROVIDE THE FOLLOWING INFORMATION:

- 1. Model and serial number**
- 2. Proof of purchase date**
- 3. A copy of the original Warranty Registration Card or Online Submission**
- 4. Details of the defect or problem (include photos and videos)**

YOU MAY BE DENIED WARRANTY COVERAGE IF YOUR MACHINE HAS FAILED DUE TO ANY OF THE FOLLOWING:

Product abuse	Normal wear
Product neglect	Accidental damage
Improper maintenance	Unapproved modifications
Improper electrical connection	

LIABILITIES

The manufacturer assumes no risk and shall be subject to no liability for damages or loss resulting from the specific use or application made of the product. In no event will the manufacturer be liable for any special, incidental or consequential damages (including loss of use, loss of profit and claims of third parties) however caused - whether by negligence of the manufacturer or otherwise. If you have any questions regarding your warranty rights and responsibilities, please contact the manufacturer.

LEGALITIES

CenturionPro trimming machines are intended for use on legal aromatic herbs and hops. Please check all municipal, provincial/state and federal laws and regulations before using these machines. CenturionPro Solutions does not promote or condone the use of these products in any way that may be deemed illegal. Allow only persons who understand this disclaimer to operate the machines.

NOTES



A large grid of small dots for taking notes.

FOR ALL OTHER ISSUES, PLEASE EMAIL techsupport@cprosolutions.com, WE WOULD BE HAPPY TO HELP YOU.

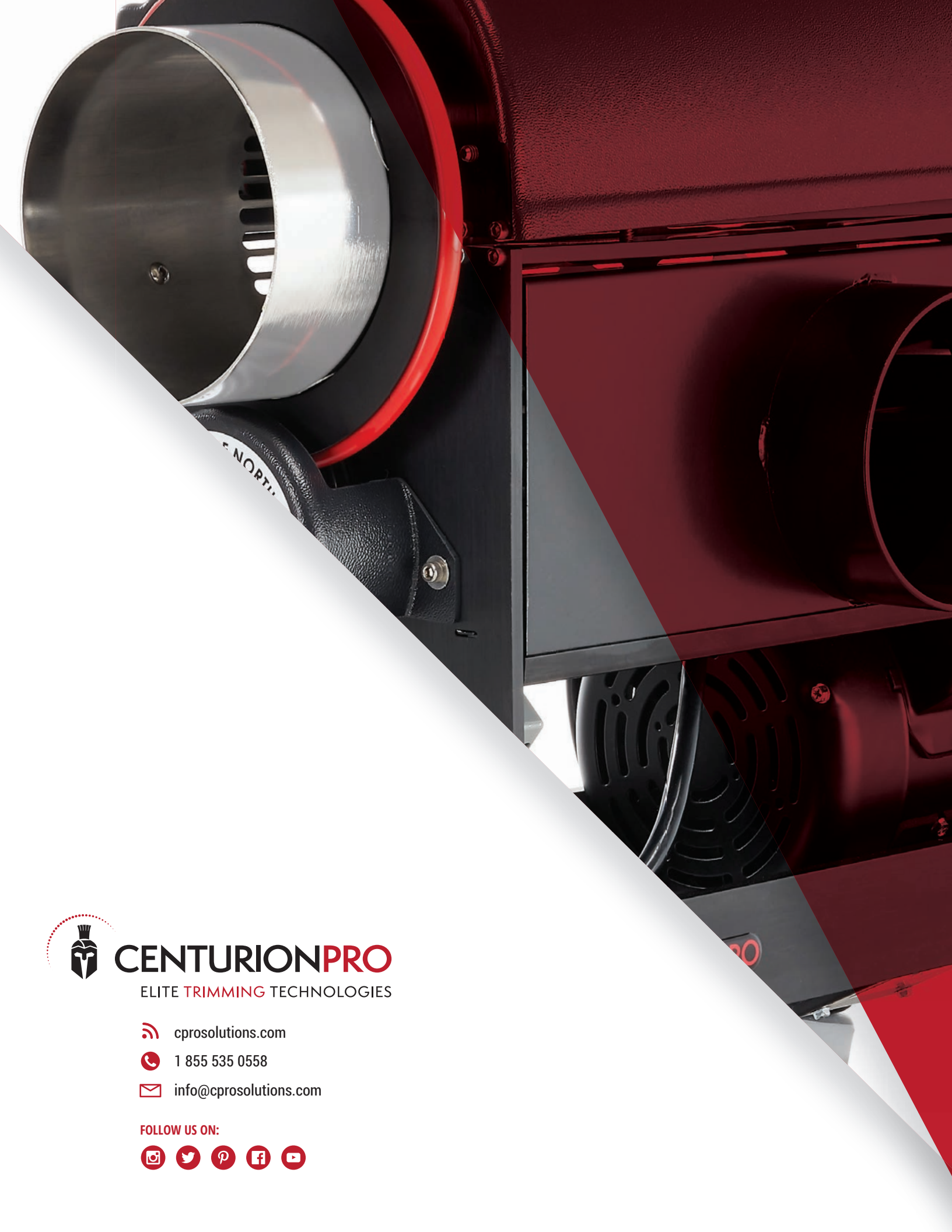

CENTURIONPRO

ELITE TRIMMING TECHNOLOGIES

 cprosolutions.com

 1 855 535 0558

 info@cprosolutions.com

FOLLOW US ON:

