

EG

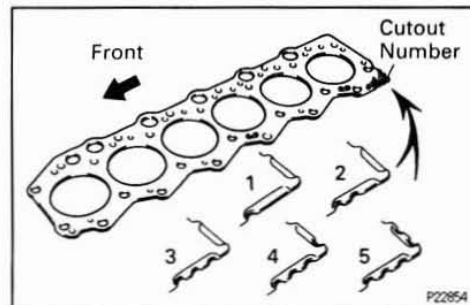
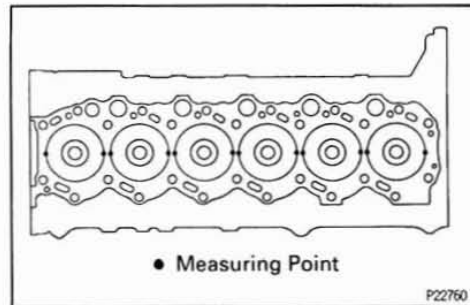
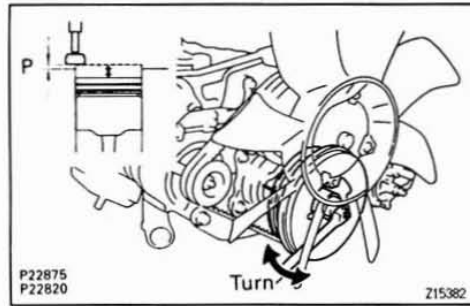

## CYLINDER HEAD INSTALLATION

### 1. CHECK PISTON PROTRUSION AND SELECT CYLINDER HEAD GASKET

#### A. Check piston protrusions for each cylinder

- Clean the cylinder block with solvent.
- Set the piston of the cylinder to be measured to slightly before TDC.
- Place a dial indicator on the cylinder block, and set the dial indicator at 0 mm (0 in.).

#### HINT:

- Use a dial indicator measuring tip as shown in the illustration.
  - Make sure that the measuring tip is square to the cylinder block gasket surface and piston head when taking the measurements.
- Find where the piston head protrudes most by slowly turning the crankshaft clockwise and counterclockwise.
  - Measure each cylinder at 2 places as shown in the illustration, making a total of 12 measurements.
  - For the piston protrusion value of each cylinder, use the average of the 2 measurements of each cylinder.

#### Protrusion (P):

0.175 – 0.425 mm (0.0069 – 0.0167 in.)

When removing piston and connecting rod assembly: If the protrusion is not as specified, remove the piston and connecting rod assembly and reinstall it. (See cylinder block disassembly and assembly)

#### B. Select new cylinder head gasket

HINT: There are 5 types of gasket (cutout number 1 to 5) installed at factory, but only 3 types for supply parts (cutout number 1, 3 and 5), so when replacing the gasket select from one of 3 types above.

#### New installed cylinder head gasket thickness:

##### Cutout number 1

0.85 – 0.95 mm (0.0335 – 0.0374 in.)

##### Cutout number 3

0.95 – 1.05 mm (0.0374 – 0.0414 in.)

##### Cutout number 5

1.05 – 1.15 mm (0.0414 – 0.0453 in.)

Select the largest piston protrusion value from the measurements made, then select a new appropriate gasket according to the table below.

Piston protrusion	Gasket size
0.225 mm (0.0089 in.) or less	Use 1
0.226 – 0.325 mm (0.0089 – 0.0128 in.)	Use 3
0.326 mm (0.0128 in.) or more	Use 5



EG

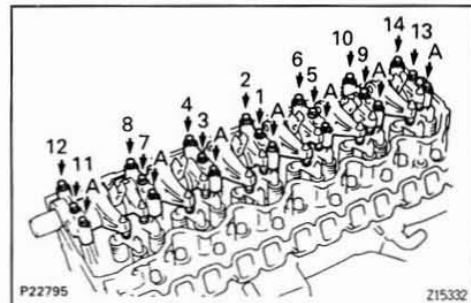
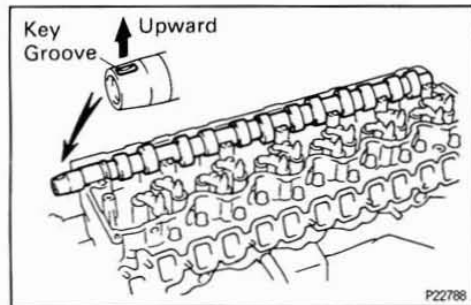
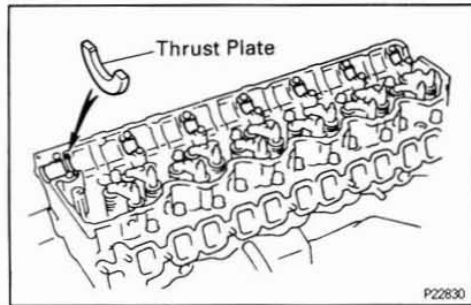
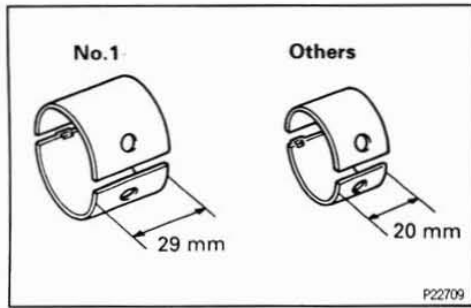

#### 4. INSTALL CAMSHAFT, CAMSHAFT BEARING CAPS VALVE ROCKER ARMS NOZZLE HOLDER CLAMPS AND ROCKER SHAFT ASSEMBLY

HINT: Camshaft bearings come in widths of 20 mm (0.79 in.) and 29 mm (1.14 in.). Install the 29 mm (0.886 in.) bearings in the No.1 cylinder head journal positions with the camshaft bearing cap. Install the 20 mm (0.79 in.) bearings in the other positions.

(a) Install the 7 lower camshaft bearings and thrust plate.

(b) Place the camshaft on the cylinder head, facing the key groove upward.

(c) Install the 7 upper camshaft bearings to the bearing caps.

(d) Install the 7 bearing caps, 12 rocker arms, 6 holder clamps and rocker shaft assembly.

(e) Install and uniformly tighten the 14 bearing cap bolts in several passes, in the sequence shown.

**Torque: 25 N·m (250 kgf·cm, 18 ft·lbf)**

(f) Install the 7 others bolts.

**Torque: 25 N·m (250 kgf·cm, 18 ft·lbf)**

#### 5. INSTALL INJECTION NOZZLES

(See steps 1, 2 and 4 in injection nozzles installation in Fuel System)

#### 6. INSTALL CAMSHAFT OIL SEAL RETAINER

(a) Remove any old packing (FIPG) material and be careful not to drop any oil on the contact surfaces of the oil seal retainer and cylinder head.

- Using a razor blade and gasket scraper, remove all the oil packing (FIPG) material from the gasket surfaces and sealing groove.
- Thoroughly clean all components to remove all the loose material.

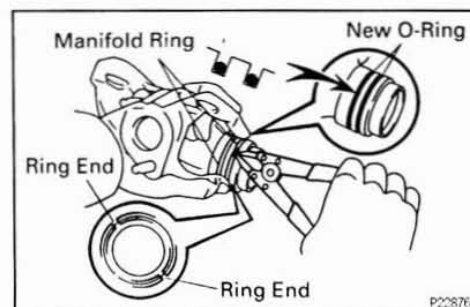
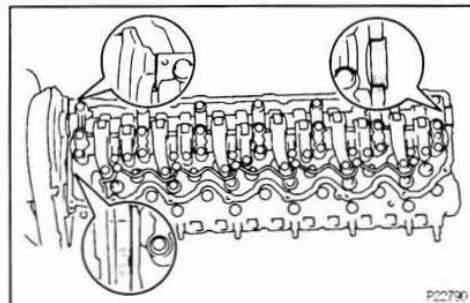
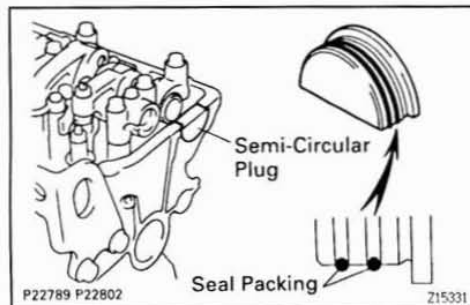
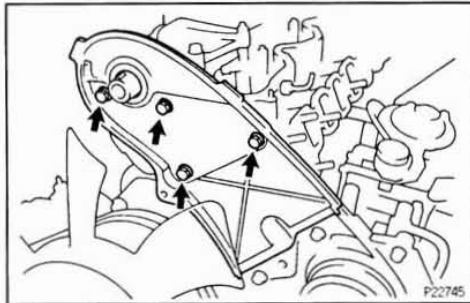
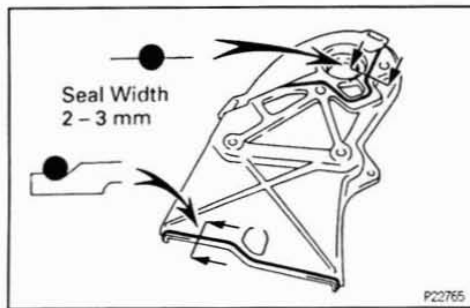

- Using a non-residue solvent, clean both sealing surfaces.

- (b) Apply seal packing to the oil seal retainer as shown in the illustration.

**Seal packing:**

**Part No. 08826-00080 or equivalent**

- Install a nozzle that has been cut to a 2 – 3 mm (0.08 – 0.12 in.) opening.
- Parts must be assembled within 5 minutes of application. Otherwise the material must be removed and reapplied.
- Immediately remove nozzle from the tube and reinstall cap.

- (c) Install the oil seal retainer with the 4 bolts. Uniformly tighten the bolts in several passes.

**Torque: 19.6 N·m (200 kgf·cm, 14 ft·lbf)**

**7. INSTALL PULLEYS AND TIMING BELT**

(See steps 1 and 4 to 10 in timing belt installation)

**8. CHECK AND ADJUST VALVE CLEARANCE**

(See steps 2 to 4 in valve clearance inspection and adjustment)

**9. INSTALL SEMI-CIRCULAR PLUG**

- (a) Remove any old packing (FIPG) material.
- (b) Apply seal packing to the semi-circular plug as shown in the illustration.

**Seal packing:**

**Part No. 08826-00080 or equivalent**

- (c) Install the semi-circular plug to the cylinder head.

**10. INSTALL CYLINDER HEAD COVER**

- (a) Remove any old packing (FIPG) material.
- (b) Apply seal packing to the cylinder head as shown in the illustration.

**Seal packing:**

**Part No. 08826-00080 or equivalent**

- (c) Install the gasket to the cylinder head cover.
- (d) Install the cylinder head cover with 12 new seal washers and 12 bolts. Uniformly tighten the bolts in several passes.

**Torque: 6.4 N·m (65 kgf·cm, 57 in.-lbf)**

**11. INSTALL REAR ENGINE HANGER**

**Torque: 39.2 N·m (400 kgf·cm, 29 ft·lbf)**

**12. ASSEMBLE EXHAUST MANIFOLDS**

- (a) Install 2 new O-rings to the rear exhaust manifold.
- (b) Using snap ring pliers, install the 2 rings to the rear exhaust manifold.
- (c) Position the rings so that the ring ends are as shown. **NOTICE: Do not align the ring ends.**

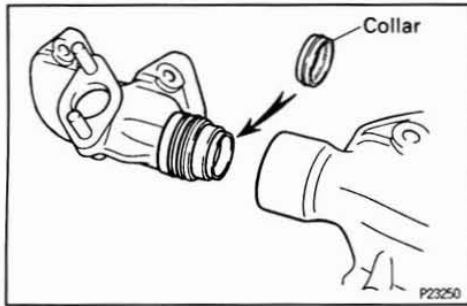

- (d) Install the collar to the rear exhaust manifold.  
 (e) Assemble the front and rear exhaust manifolds.

### 13. INSTALL EXHAUST MANIFOLD TO TURBOCHARGER

(See step 2 in turbocharger installation in Turbocharger System)

### 14. INSTALL TURBOCHARGER AND EXHAUST MANIFOLDS ASSEMBLY

(See steps 4, 5 and 6 to 9 in turbocharger installation in Turbocharger System)

### 15. INSTALL WATER OUTLET

- (a) Install a new gasket to the intake manifold.  
 (b) Connect the water bypass hose to the water outlet.  
 (c) Install the water outlet with the 2 nuts.  
 Torque: 19.6 N·m (200 kgf·cm, 14 ft·lbf)

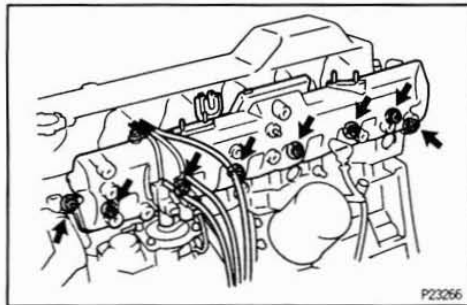
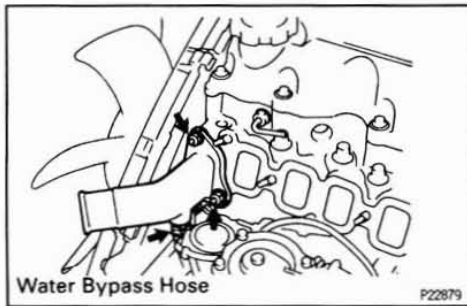

### 16. INSTALL INTAKE MANIFOLD

- (a) Install 2 new gaskets and the intake manifold with the 8 seal washers and 8 nuts. Uniformly tighten the nuts in several passes.  
 Torque: 19.6 N·m (200 kgf·cm, 14 ft·lbf)

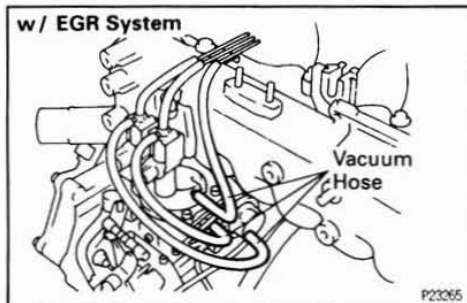

- (b) w/ EGR System:  
 Connect the 3 vacuum hoses to the injection pump.

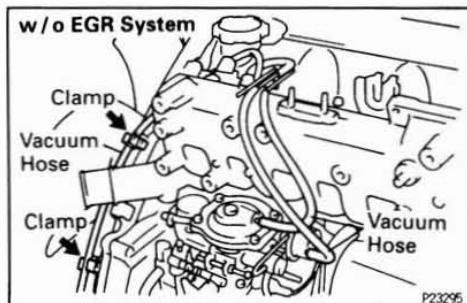

- (c) w/o EGR System:  
 Connect these vacuum hoses:
- 2 vacuum hoses to injection pump
  - Vacuum hose to 2 clamps on timing belt cover

### 17. INSTALL INJECTION PIPES

(See steps 3 and 5 in injection nozzles installation in Fuel System)

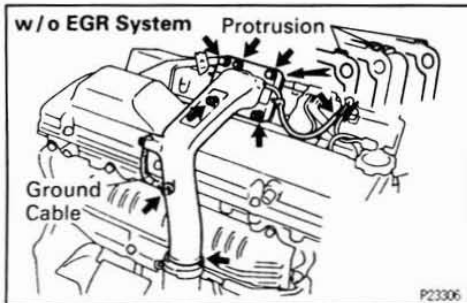
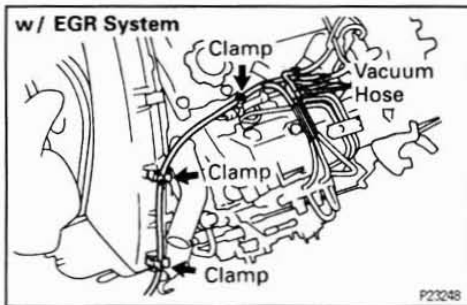
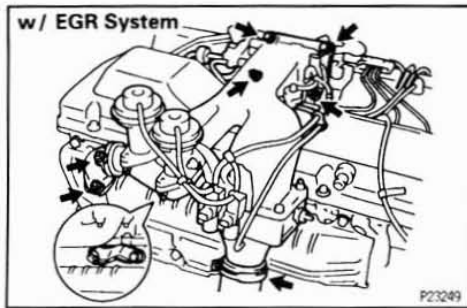
**18. w/ EGR System:****INSTALL INTAKE PIPE ASSEMBLY**

- (a) Place the intake pipe insulator on the cylinder head.
- (b) Install a new gasket to the intake manifold.  
**NOTICE: Be careful of the installation direction.**
- (c) Install a new gasket to the exhaust manifold.
- (d) Connect the intake pipe to the air hose.
- (e) Place the intake pipe assembly on the intake manifold and exhaust manifold.
- (f) Install the 2 bolts and 2 nuts holding the intake pipe to the intake manifold.

**Torque: 19.6 N·m (200 kgf·cm, 14 ft·lbf)**

- (g) Install the 2 nuts holding the EGR valve adapter to the exhaust manifold.  
**Torque: 40 N·m (400 kgf·cm, 26 ft·lbf)**
- (h) Install the EGR valve bracket with the 2 bolts. Alternately tighten the bolts in several passes.  
**Torque: 20 N·m (200 kgf·cm, 15 ft·lbf)**
- (i) Install the vacuum hose to the 3 clamps on the timing belt cover and fuel return hose.
- (j) Connect the 3 vacuum hoses to the vacuum pipe on the intake manifold.

**19. w/o EGR System:****INSTALL INTAKE PIPE AND INTAKE HEATER**

- (a) Place the intake pipe insulator on the cylinder head.
- (b) Install a new gasket, the intake heater and a new gasket to the intake manifold.  
**NOTICE: Be careful of the installation direction.**
- (c) Connect the intake pipe to the air hose.
- (d) Install the intake pipe to the intake manifold with the 3 bolts and 2 nuts.

**Torque:**

**10 mm head**

**7.5 N·m (75 kgf·cm, 66 in.-lbf)**

**12 mm head**

**19.6 N·m (200 kgf·cm, 14 ft·lbf)**

- (e) Install the ground cable to the cylinder head with the bolt.
- (f) Connect the vacuum hose to the vacuum pipe on the intake manifold.

**20. FILL WITH ENGINE COOLANT****21. START ENGINE AND CHECK FOR LEAKS****22. RECHECK ENGINE COOLANT LEVEL AND OIL LEVEL**

# CYLINDER BLOCK COMPONENTS FOR PREPARATION AND AFTER ASSEMBLY

EG

