

SG

MAVERICK

MICROBE

MICROBE **FLUX**



Startup Guide



Vol.3 150800-006 SG

Thank you for selecting this Maverick RC product!

HAVE FUN! But please read this first!!

We know you will have great fun with your model, but to get the best from your purchase, please read this information before operating your model.



Safety precautions

WARNING! THIS IS NOT A TOY

This product is an authentic hobby-grade radio-controlled vehicle (RC vehicle) and not a toy.

Please read the enclosed instructions carefully and follow all product warnings for all accessories used with this product, including batteries, chargers, tools, adhesives, electronics, and cleaning materials.

This model may require some assembly and will need regular maintenance.

Prior experience with RC models is recommended.

If you are new to radio-controlled vehicles, please ask an experienced hobbyist or retailer for advice.

- Never connect the drive battery with reversed polarity or attempt to disassemble the battery. Incorrect handling can cause short circuits or fire and is extremely dangerous.
- If you are using rechargeable batteries for the transmitter, always use a compatible charger for that battery type.
- Do not operate, display, or test this product on public roads, in crowded places, or near people or animals. Always make sure others are aware you are using this model to prevent injury or damage.
- Some parts may become hot during normal operation — handle with care.
- This product is covered by a limited warranty. Please read the enclosed warranty details for more information. Damage caused by crashes, negligence, or improper handling is not covered under warranty.

Section	Contents	Page
	Overview	4
	Main Car Components (Brushed)	5
	Main Car Components (Brushless/Flux)	6
1	Getting Started	7
1-1	Charging Car Battery	7
1-2	Setting Up the Transmitter	8
1-3	Preparing the Chassis	8
2	Setup	9
2-1	ESC/Receiver Overview	9
2-2	Binding/Pairing	10
2-3	Decals	11
3	Switching On	12
4	Using the Transmitter	13
4-1	Transmitter Information	13
4-2	Steering	14
4-3	Acceleration/Braking	14
4-4	Transmitter Indicator LEDs	15
4-5	Practice Turning	15
5	Fail Safe System	16
5-1	Checking Fail Safe	16
5-2	Fail Safe Setup	17
6	Checking Radio Range	19
7	Basic Troubleshooting	19
7-1	Steering Adjustments	19
7-2	Throttle Adjustments	20
8	After Use	21
8-1	Switching Off	21
8-2	Maintenance after driving	21
	Further Information	22
	Driving in wet conditions	22
	Troubleshooting	22

Additional Information

QS

Quick Start Guide



+



RMI

Transmitter Manual



TG

Technical Guide



+



EMI

ESC Guide



SG

This Guide



NOTE - This refers to the relevant guide (as above) and the relevant section. In this example, Section 1-1 of the ESC Manual.

Kit Contents

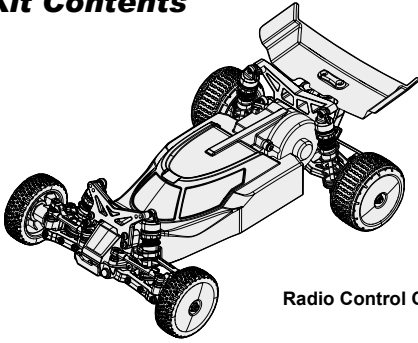

Radio Control Car

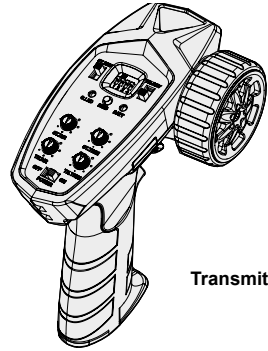

Transmitter

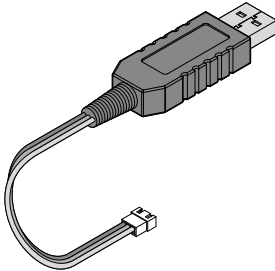

USB Battery Charger

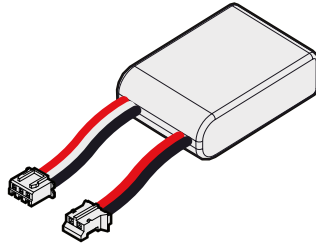

2S Li-Ion (7.4V) Battery pack

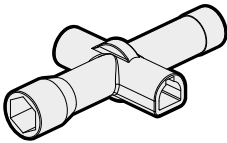

4-Way Cross Wrench (Small)

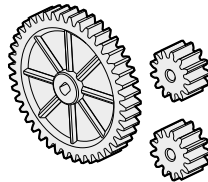

Alternate Motor Gears

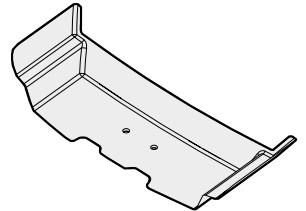

Spare transparent wing

Equipment Needed

4x

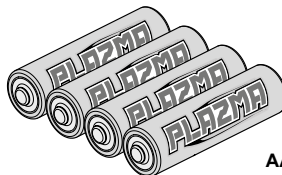

AAA Batteries for Transmitter

MAIN CAR COMPONENTS

MICROBE

**Brushed Models: 150800, 150801,
150802, 150803, 150850, 150851**

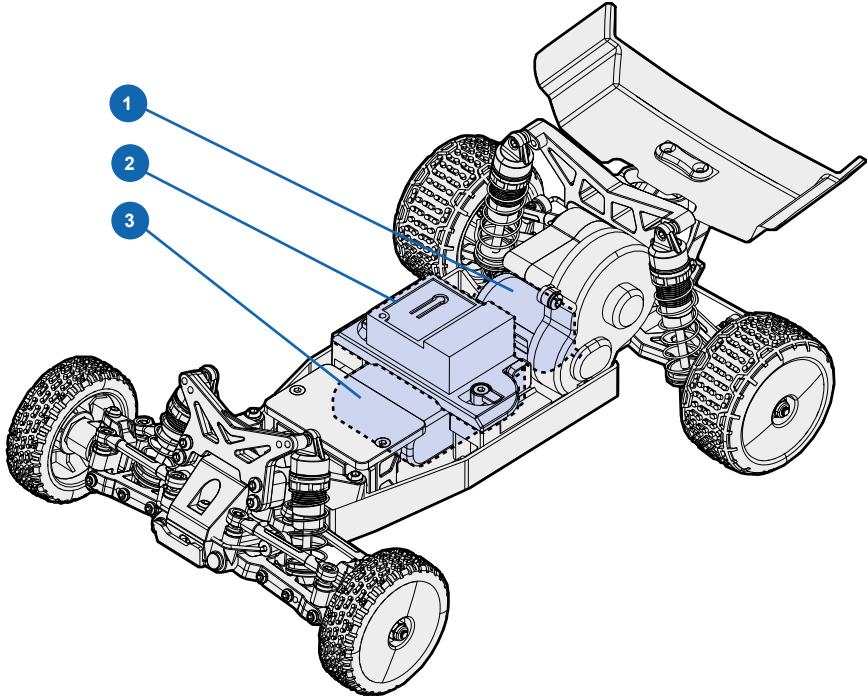

1

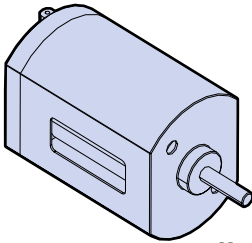

Motor

2

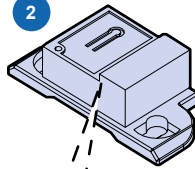

Electronic Speed Control (ESC)

3

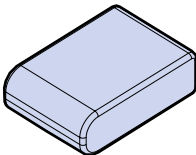

Battery

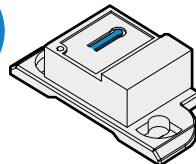

Power Switch

MAIN CAR COMPONENTS

MICROBE FLUX

Brushless Models: 150870, 150871

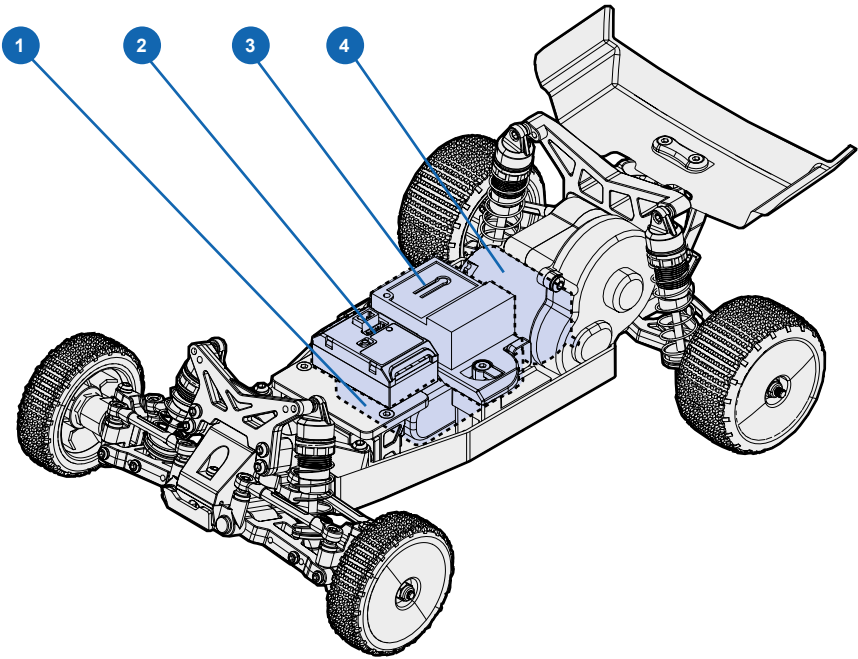

1

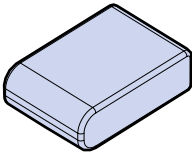

Battery

2

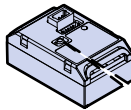

Electronic Speed Control (ESC)

3

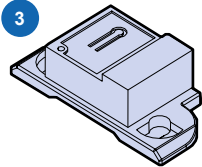

Receiver

4

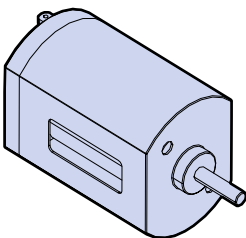

Motor

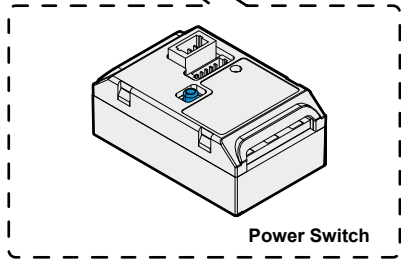

Power Switch

1-1 Charging Car Battery



Caution

- Only use the supplied charger to charge the battery pack.
- Do not leave the battery unattended while charging.
- Do not use damaged or leaking batteries or chargers.
- Children must not charge the battery without adult supervision.
- Always disconnect the battery from the ESC/Receiver and remove it from the model when not in use.
- Fully charge the battery before each run.
- Do not leave the battery uncharged for long periods.
- Do not fully discharge the battery during use.
- Charge only in dry conditions. Do not charge in wet or humid environments.

1. Connect the charger plug to the battery pack connector
The connectors are shaped and include a clip to ensure correct connection.

Do not force them together – always check the alignment first.

2. The charger will automatically begin charging.

Charging will stop automatically once the battery is fully charged.

Error: Voltage out of charging range.

If this happens repeatedly, the battery pack may be damaged and should be replaced.

LED Status

	Solid Red:	Charging
	LED OFF	Fully Charged
	Flashing Red (No Battery pack plugged in)	Standby
	Flashing Red (Battery pack plugged in)	Error

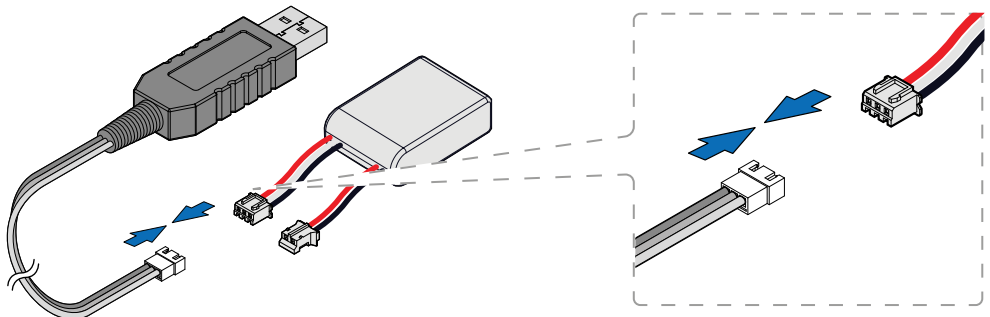

Caution

The USB charger requires a USB power adapter with an output of at least 2A.



Caution

Do not use NiCd or NiMH battery chargers for Li-ion/LiPo batteries.
Always use a charger specifically designed for Li-ion/LiPo batteries to prevent damage.

1-2 Setting Up the Transmitter

1-2-1 Transmitter Battery Installation

- 1** Open battery cover at the bottom of transmitter.

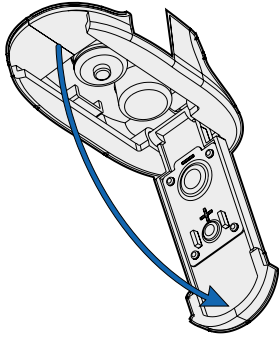

- 2** Insert 4 fully-charged AAA batteries into the compartment checking the polarity.

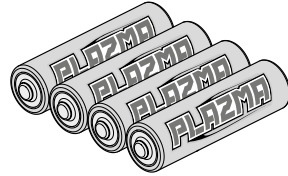

1-3 Preparing the Chassis

1-3-1 Access Battery

- 1** The Microbe body is held on with Velcro in the areas shown. Gently pull the body sides to release Velcro, then lift off body shell. Lastly slide the nose out from the front shock tower.

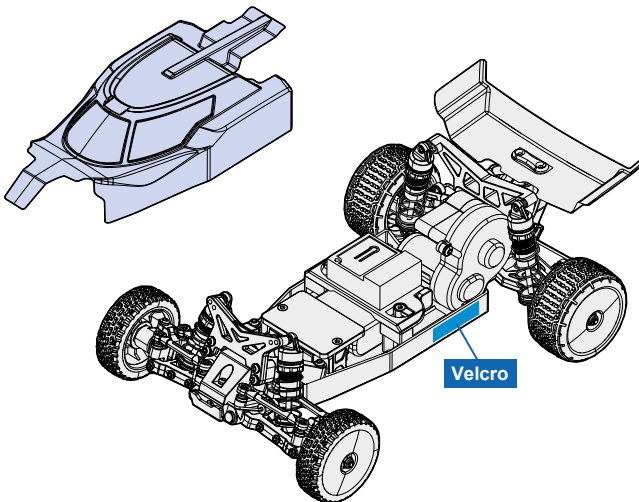

- 2** The battery is accessed by removing the ESC mount. Locate rear tabs as shown.

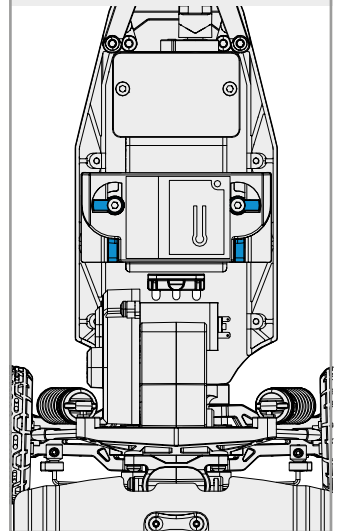

3

Rotate tabs to release ESC mount

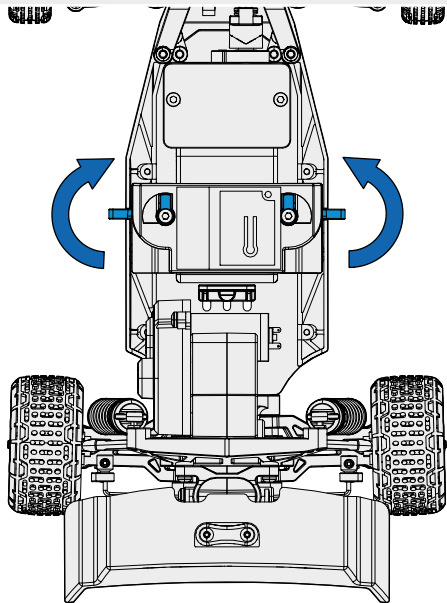

4

Remove ESC mount and battery. Disconnect Battery from ESC AFTER removal

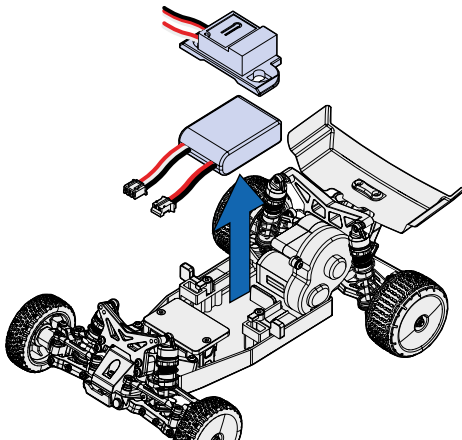

5

Installation is the reverse of removal.

2 SETUP

MICROBE

2-1 ESC/Receiver Overview

The ESC and Receiver are preset at the factory for correct operation with the supplied Transmitter and Battery.



Tip

If you wish to customize your vehicle, several parameters can be adjusted. See the ESC manual for details



EM 2

2-2 Binding/Pairing

Programming a receiver to recognize the code of only one specific transmitter. Binding and fail-safe is preset from the factory.



Cautions

Any new binding of transmitter & receiver will clear the preset fail safe.



Cautions

If you change transmitters or add a receiver, you must re-bind before operating your vehicle.

- 1** Place the transmitter and the receiver close to each other (within one meter). Press and hold the transmitter bind button

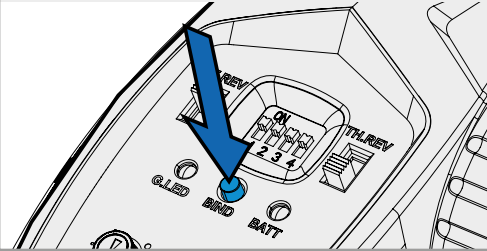

- 2** Turn the power switch to the ON position. The Power LED will flash quickly. Release the setup button after 1 second.

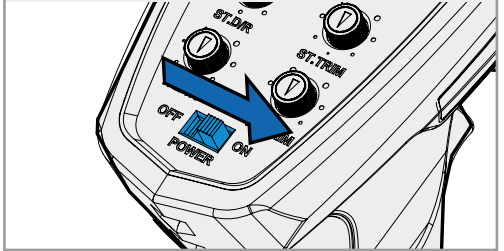

- 3^A** Press the power switch on the ESC/Receiver to the ON position. Wait for 1 second. The LED will flash quickly until the connection is established. (Models 150800, 150801, 150802, 150803, 150850, 150851)

- 3^B** Press the power switch on the ESC/Receiver to the ON position. Wait for 1 second. The LED will flash quickly until the connection is established. (Models 150870, 150871)

MICROBE

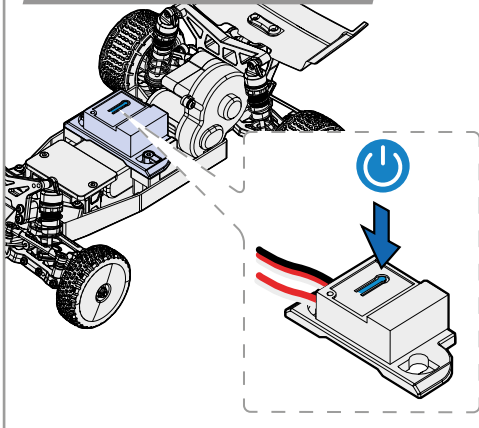

MICROBE FLUX

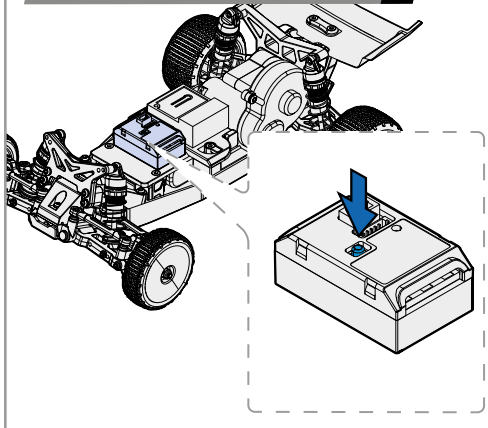

2-3 Decals

A decal sheet is included. Our suggestion for placement is as shown, but feel free to customize your car however you like!

2-3-1 Models 150800, 150801, 150802, 150803, 150850, 150851

MICROBE

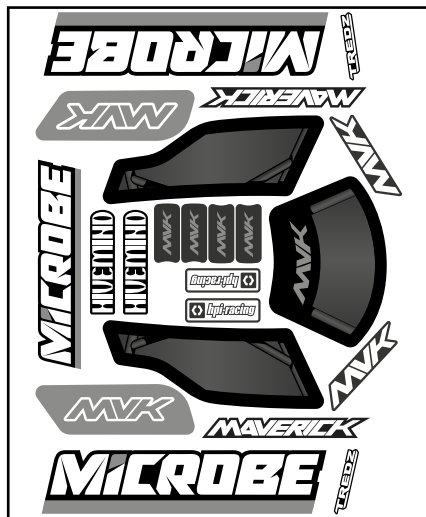

2-3-2 Models 150870, 150871

MICROBE FLUX

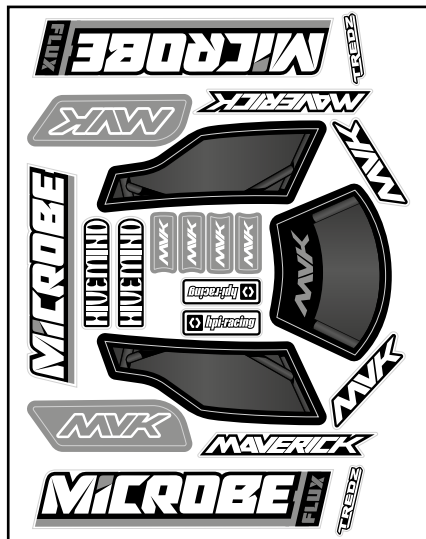

3 SWITCHING ON

MICROBE

1^A Ensure Car Battery is connected.
(Models 150800, 150801, 150802, 150803,
150850, 150851)

MICROBE

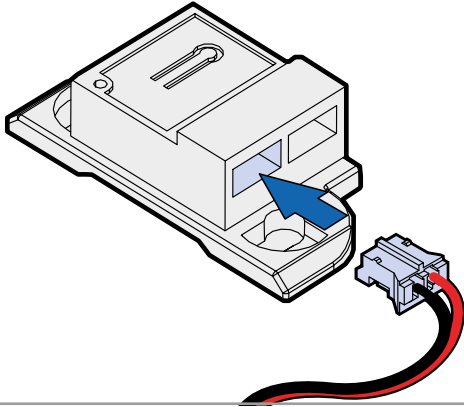

1^B Ensure Car Battery is connected. (Models
150870, 150871)

MICROBE FLUX

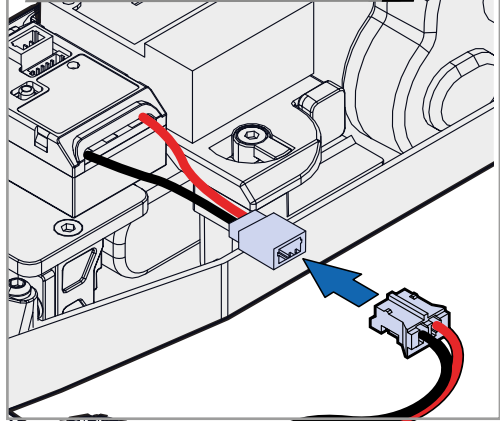

2
Switch on transmitter first

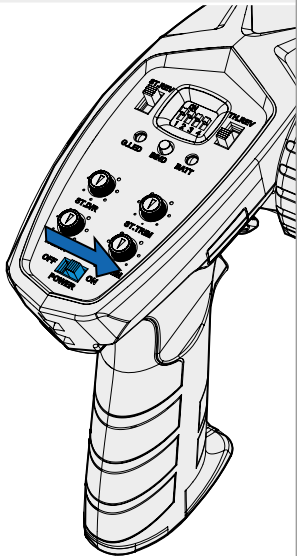

3^A Then switch on car power.
(Models 150800, 150801,
150802, 150803, 150850,
150851)

MICROBE

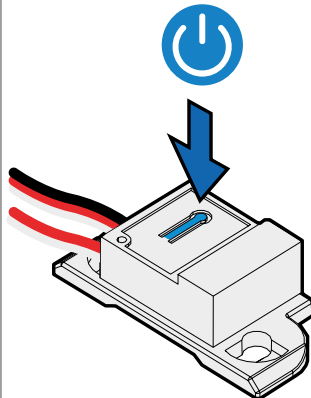

3^B Then switch on car power.
(Models 150870, 150871)

MICROBE FLUX

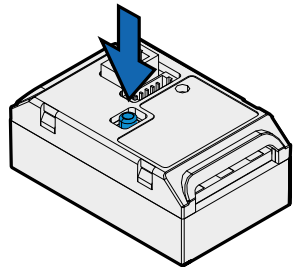

4-1 Transmitter Information

- 1 Steering Trim
- 2 4-bit DIP Switch
- 3 Status Indicator
- 4 BIND Button
- 5 Reverse the steering function.
- 6 Throttle Speed Limiter Switch
- 7 Power on/ off
- 8 Reverse the throttle function.
- 9 Steering Wheel (CH1)
- 10 Battery/Power Indicator
- 11 Steering Trim
- 12 Throttle Trim
- 13 Battery Compartment
- 14 Throttle Trigger
- 15 USB port

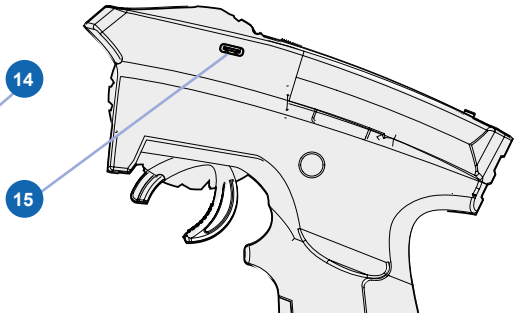
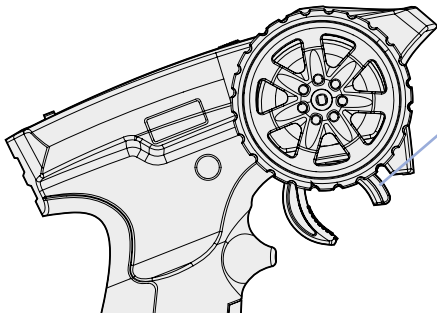
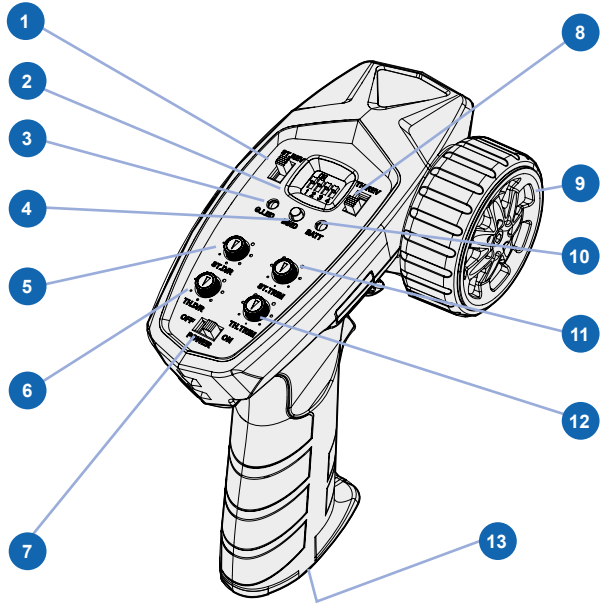

4-2 Steering

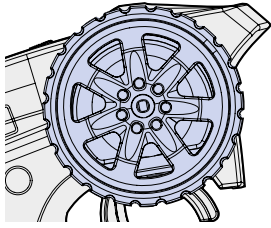

Neutral

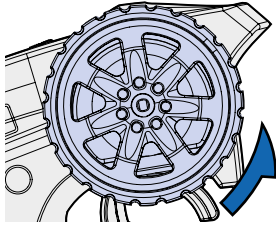
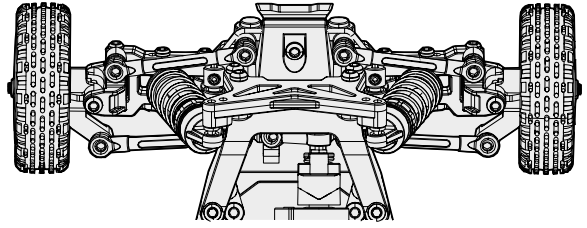

Left

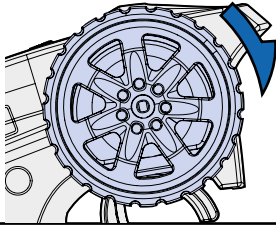
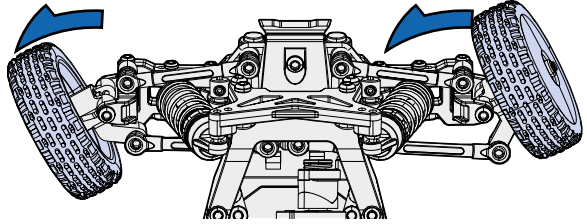

Right

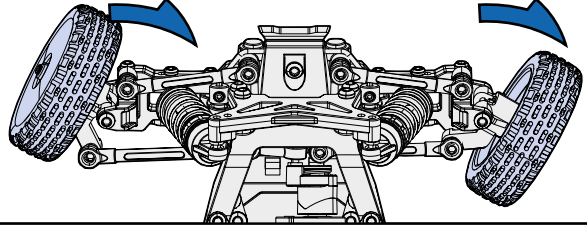

4-3 Acceleration/Braking

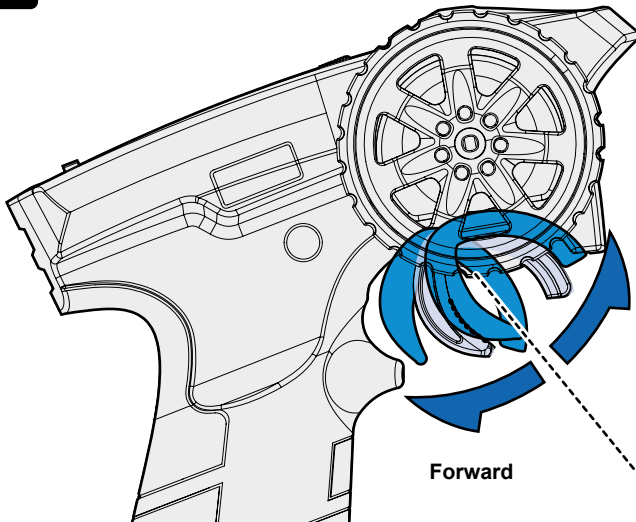

Brake / Reverse

Forward

Stop (Neutral)

4-4 Transmitter Indicator LEDs

4-4-1 Status Indicator

The battery power indicator for the Transmitter

1. Solid Green - Battery Power High
2. Solid Yellow - Battery Power Medium
3. Solid Red - Battery Power Low
4. Flashing Red - Battery Power very low
5. Rapid Flashing Green - Binding Mode
6. Slow Flashing Green - Idle mode

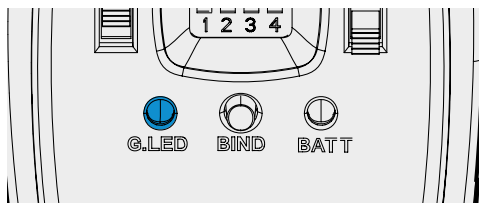

4-4-2 BATT Indicator

The battery power indicator for the 2-in-1 receiver

1. Solid Green - Battery Power High
2. Solid Yellow - Battery Power Medium
3. Solid Red - Battery Power Low
4. Flashing Red - Battery Power very low
5. Slow flashing Green - Transmitter calibration mode

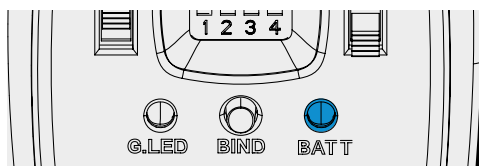

Note: In three seconds after the power-on of the transmitter, the BATT LED indicates the transmitter battery power status. When the transmitter is powered on for 3 seconds, the receiver battery power status is indicated.

When the transmitter does not receive the return message, the BATT LED will be off.

When the receiver is de-bound, the BATT LED will maintain in the state when the receiver is de-binding.

4-5 Practice Turning

Install body and enjoy!

Allow the car to cool down for 15 minutes between each run.

When the car is running toward the driver, the directions of the steering wheel are reversed.

Once you become comfortable driving your RC car, practice driving on a track with cones.

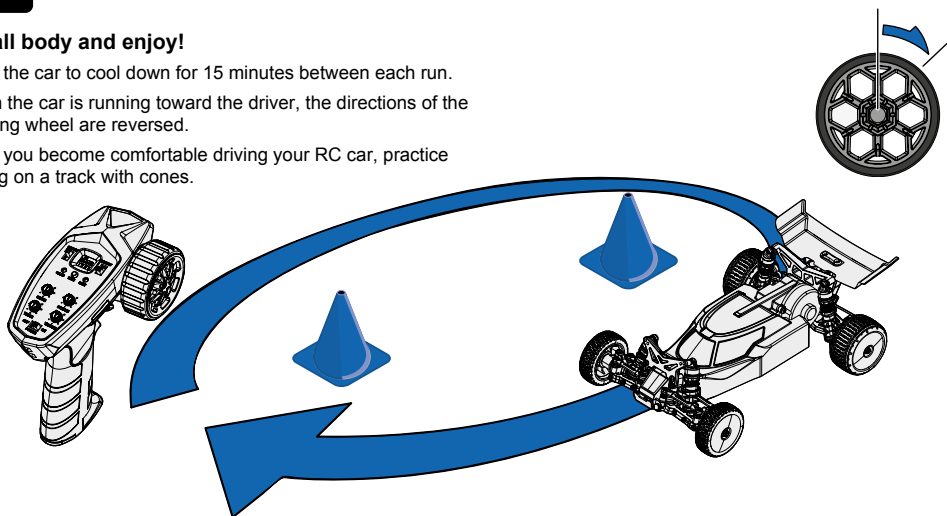

Caution

Do not run in water or sand

Do not run on public streets or highways. This could cause serious accidents, personal injuries, and/or property damage.

5-1 Checking Fail Safe

This car has a built-in fail safe system that will stop the car if the radio glitches, either because of interference or if the car goes out of range.

The fail safe system has been setup at the factory, but you should become familiar with the function of the fail safe and check the operation before running.



Caution

Any new binding of transmitter & receiver will clear the preset fail safe.



Caution

The fail safe can not completely protect your car.

- 1** Set the car so that the wheels can turn, but it will not move, either by putting on a stand or turning upside down

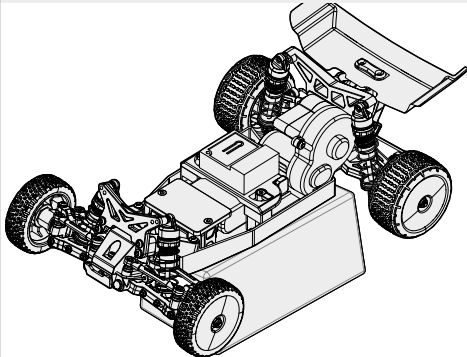

- 2** Turn on the transmitter, and then the car

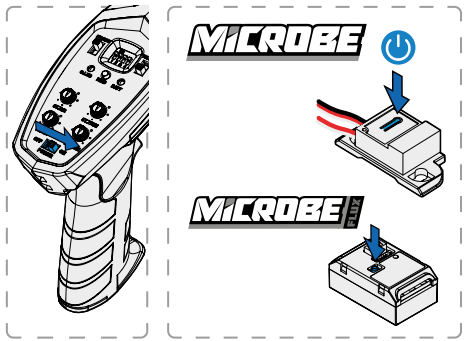

- 3** Move the throttle trigger to turn the car wheels (accelerate).

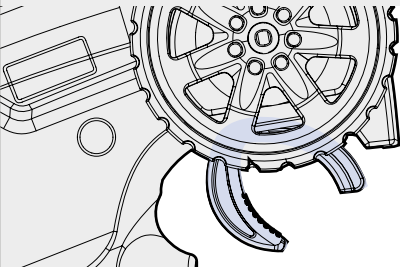

- 4** Whilst the car is running, turn off the transmitter. If the failsafe is working, the car's wheels should stop turning.

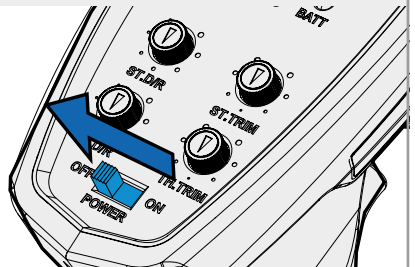

5-2 Fail Safe Setup

If the failsafe is not working correctly, work through the following steps to set it up.

Re-check the Failsafe as per section 5-1 after completion to check it has setup correctly

5-2-1 Models 150800, 150801, 150802, 150803, 150850, 150851

1 Place car on a stand and turn OFF

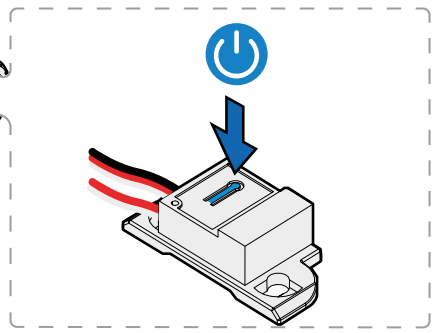
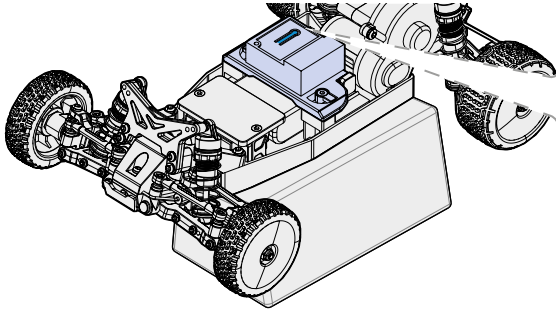

2 Connect Battery

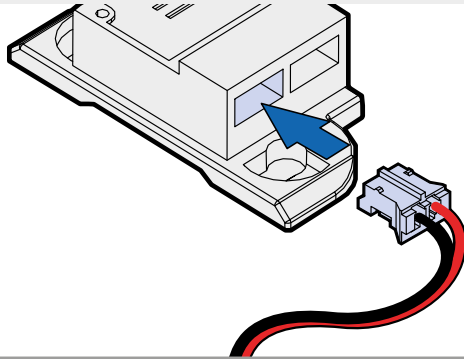

3 Switch on car and transmitter

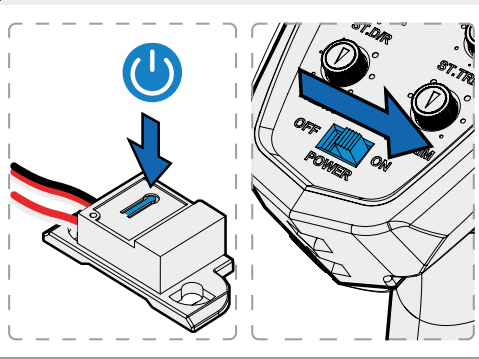

4 Press the BIND button on the receiver then release

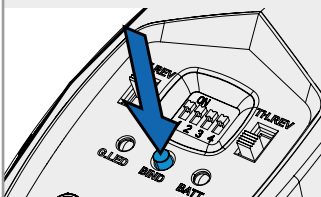

5 Leave throttle trigger in neutral position, and press the BIND button again for 3 seconds.

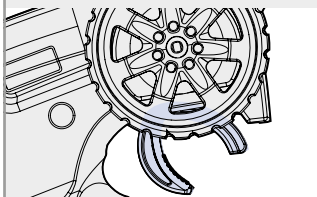

6 The G.LED will flash rapidly three times to indicate successful configuration, and the BIND button can be released.

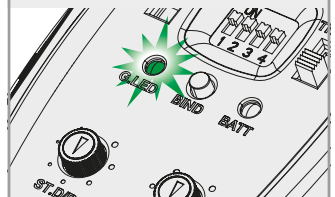

5-2-2 Models 150870, 150871

1 Place car on a stand and turn OFF

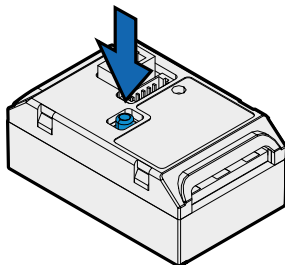
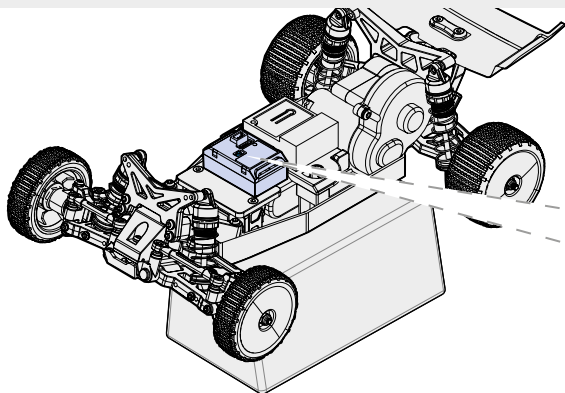

2 Connect Battery

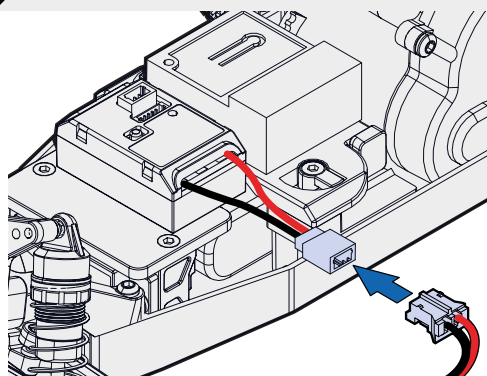

3 Switch on car and transmitter

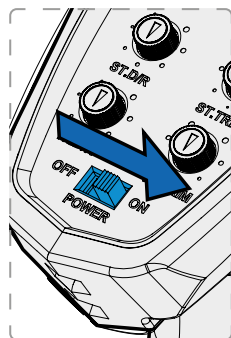
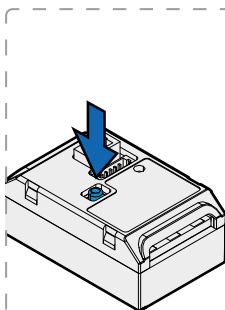

4 Press the BIND button on the receiver then release

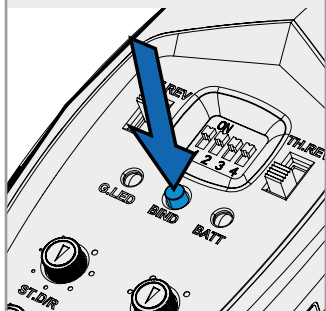

5 Leave throttle trigger in neutral position, and press the BIND button again for 3 seconds.

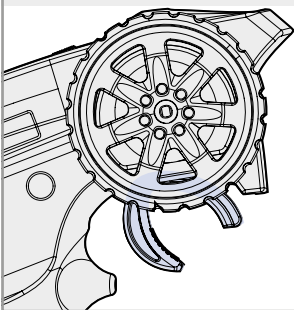

6 The G.LED will flash rapidly three times to indicate successful configuration, and the BIND button can be released.

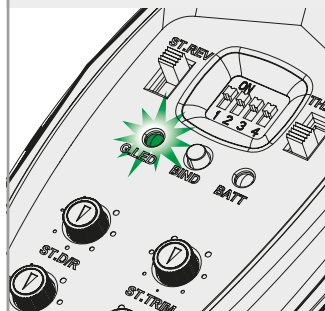

6 CHECKING RADIO RANGE

To check the radio range safely:

Ask a friend to hold the model securely while you walk to the farthest distance you plan to operate it. Use the transmitter controls to confirm that the model responds correctly.

If you notice any delay, loss of signal, or unusual behavior, do not operate the model until the issue is resolved.

Always switch on the transmitter first, then the model.

If the model is powered on before the transmitter, you may lose control.

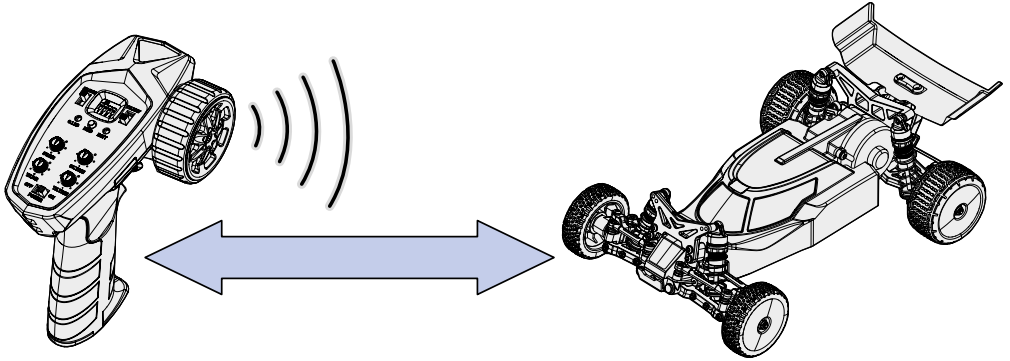

Cautions

2.4GHz radio frequency only functions by line of sight, if you drive behind a solid object or around a corner and lose sight of the vehicle you may lose control of the RC car.

7 BASIC TROUBLESHOOTING

MICROBE

7-1 Steering Adjustments

7-1-1 Steering Trim Setup

Steering Trim: Trim adjustment allows you to finely tune the inputs from your transmitter. It's the dial you reach for when your RC car isn't tracking straight. The steering trim is what helps navigate the RC car in a straight line.

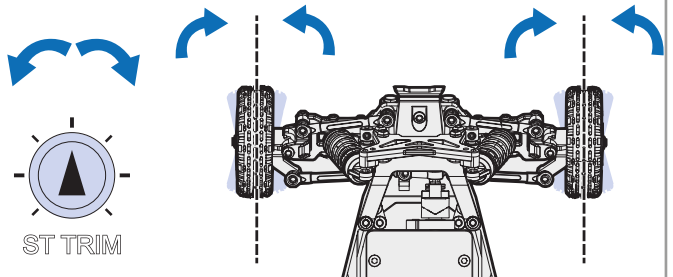

7-1-2 Steering Dual Rate Setup

The steering Dual Rate knob can be set to control the steering throw:

Turn the knob clockwise to increase the steering throw.

Turn the knob anticlockwise to reduce the steering throw.

The steering rudder amount is recommended to be controlled within 75% to avoid excessive steering resulting in friction between the front wheel and the car shell, and the appropriate steering range can better maintain the body attitude and control comfort.

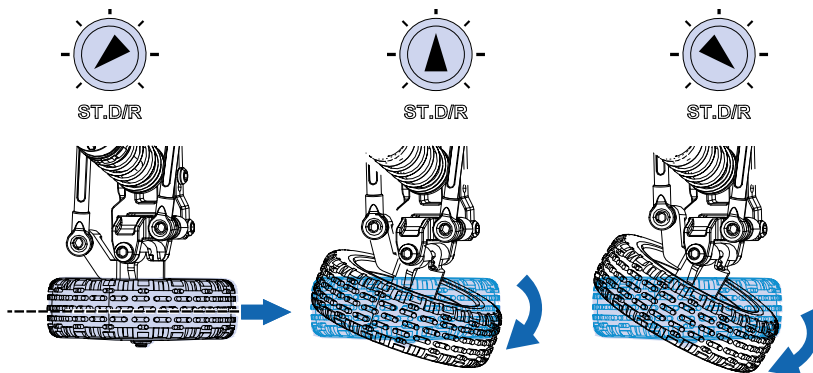

7-2 Throttle Adjustments

7-2-1 Throttle Trim

The throttle trim adjusts the neutral (center) point of the electronic speed controller (ESC).

If your car creeps forward or backward when the throttle trigger is at neutral, you can use throttle trim to fine-tune it so the car stays still.

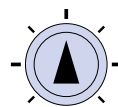

TH TRIM
Set TH Trim to center position for electric cars.

7-2-2 Throttle Dual Rate

The throttle dual rate (TH-D/R) setting controls how much of the full throttle range from your transmitter is actually used.

For an electric car, this can be used to limit top speed.

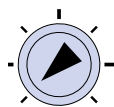

TH.D/R

Low speed

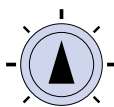

TH.D/R

Medium speed

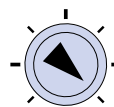

TH.D/R

Maximum Speed

8-1 Switching Off

IMPORTANT: Always power OFF the ESC/Receiver before the transmitter.

1. Remove the car body
2. Switch off the vehicle's ESC/Receiver (short press ≤ 1 second) power and disconnect the battery.
3. Turn off the transmitter power
4. Remove the battery when not using the car. See **section 1-3**



Caution

Always power OFF the ESC/Receiver before the transmitter to prevent loss of control.



Caution

Disconnect the battery whenever the model is not in use.
If left connected, the vehicle may start unexpectedly or the battery may overheat and cause a fire.

8-2 Maintenance after driving

Regular maintenance is very important to keep your RC model in top condition.

After each run, clean the chassis and check all moving parts for any damage or wear.

If any parts are broken or worn out, repair or replace them before your next run.

Routine maintenance helps prevent damage and keeps your model performing reliably.

Completely remove any dirt or debris from the model, paying special attention to the suspension, drive shafts, and steering components.

Check that all screws and fasteners are tight and that no parts are missing or loose.

Use the schedule below as a general maintenance guide.

Interval	Maintenance Item
After every run	Clean chassis and suspension, remove dirt and debris.
Every 10 runs	Check wheels, tires, and bearings. Inspect gears and drive-train for wear.
Every 20 runs	Inspect and clean motor and pinion gears. Check differential and shock absorbers. Lubricate moving parts.
Occasionally	Check radio system, wiring, and connectors. Replace batteries if needed.



Tip

Perform maintenance more frequently if driving in dusty, wet, or sandy conditions.

Driving in wet conditions

This model is not designed to be used in wet conditions.

Troubleshooting

If R/C car does not move or you have no control, see below.

If you encounter any other fault whilst operating the vehicle please contact your local hobby shop.

Problem	Cause	Remedy
Does Not Move	Battery is not placed properly in the transmitter.	Place batteries in the transmitter properly.
	Weak or no batteries in transmitter or model.	Install charged or fresh batteries.
	Damaged motor.	Replace with new motor.
	ESC is shut down by heat protection circuit.	Stop driving immediately, do not drive the car until the Speed Controller cools down.
	Binding Setup is incorrect.	Make sure binding is setup properly.
The vehicle does not follow your driving inputs	Servo reverse switch is in the wrong position.	Check the reverse switch settings
	Wires from ESC to motor are improperly connected.	Connect wires from ESC to motor correctly
	Neutral position or trim is incorrect.	Adjust the steering trim.



MVK

HPI RACING A/S

Jegindoevej 21

8800 Viborg, Denmark

Email: info@hpiracing.com

WWW.MAVERICK-RC.COM