

Atmospheric - Types 3000, 3000C, 3001, 3001C, 3002, 3002C

Superior offers the most complete range of refrigeration relief valves in the industry. All valves have been designed, constructed and rated in accordance with ANSI/ASHRAE 15-1994 Standard Safety Code for Mechanical Refrigeration.

Each valve is stamped U.V./N.B. to indicate National Board certifications as to capacities. Certified National Board ratings are printed on the next page.

These pressure-relief valves are all PTFE seated, permitting their use in applications of either high or low temperatures where the conventional rubber seated valves are often completely unsatisfactory.

Part Numbers indicate style and size of relief valve only – customer must specify pressure setting when ordering.

Note: Prior to installation or during pressure vessel testing, Superior pressure-relief valves should not be discharged. Any dirt in the system may embed in the seat and prevent the pressure-relief valve from resealing properly.

Important: A pressure-relief valve is installed in a refrigeration system primarily to protect the receiver. Since it is not intended to be an overload or high-pressure cutout, we recommend that the pressure-relief valve be set at the working pressure marked on the receiver, regardless of the type of refrigerant used. The method for determining “set pressure” is outlined in ANSI/ASHRAE 15 Standard Safety Code for Mechanical Refrigeration.

Note: Pressure-relief valves cannot be returned to the factory. This policy helps maintain product integrity.

- Body construction: brass
- Seat material: 100% PTFE
- Spring material: stainless steel
- Minimum temperature: -40° F
- Maximum temperature: 325°F
- Initial leak: set pressure \pm 3%
- Full discharge: initial leak +10%
- ASME Certificate No. 16-564
- CRN 0G8195.5C
- RoHS compliant
- N.B. Certificate Nos.: 3000 Series M41173, 3020 Series M41184, 3030 Series M41195, 3060 Series M41207



Atmospheric — Types 3000 & 3000C, 3001 & 3001C, 3002 & 3002C

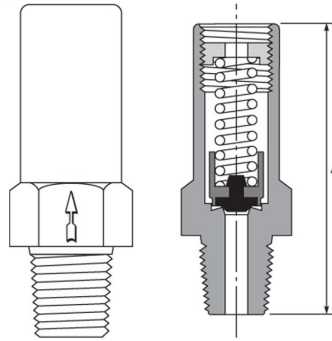

Part Number	Port Diameter	Size (Inches)		Dimensions A (inches)	Discharge Capacity (psig)						
		Inlet NPT	Outlet		235	300	350	400	425	450	500
Types 3000, 3001, 3002											
3000	3/16	1/8	*	2.17	7.9	10.0	11.6	13.2	X	14.7	X
3001	3/16	1/4	*	2.30	7.9	10.0	11.6	13.2	14.0	14.7	16.3
3002	3/16	3/8	*	2.30	7.9	10.0	11.6	13.2	14.0	14.7	16.3

Part Number	Port Diameter	Size (Inches)		Dimensions A (inches)	Discharge Capacity (psig)					
		Inlet NPT	Outlet		550	600	650	700	750	800
Types 3000C, 3001C, 3002C										
3000C	3/16	1/8	*	2.17	17.9	19.5	X	22.7	X	X
3001C	3/16	1/4	*	2.30	17.9	19.5	21.1	22.7	24.3	25.9
3002C	3/16	3/8	*	2.30	17.9	19.5	21.1	22.7	X	X

* Atmospheric - No external connection.

X - Valve unavailable at pressure setting

RoHS Compliant

Discharge capacities shown in pounds air per minute.
To convert pounds air per minute to standard cubic feet per minute, multiply by 13.1.

Selection of Relief Valves for Commercial Refrigeration and Air Conditioning Applications based on ANSI/ASHRAE Standard

To select a pressure-relief valve, it is necessary first to determine the discharge capacity required to protect the refrigerant-containing vessel under consideration. The ANSI/ASHRAE Standard 15 states that the required discharge capacity of a pressure-relief valve used on such a vessel is directly proportional to the size of the vessel. Once the size of the vessel to be protected is known, the required discharge capacity of the pressure-relief valve may then be determined by using the following formula:

$$C = fDL$$

Where: C = minimum required discharge capacity of the pressure-relief device in pounds of air per minute (kg/sec).

f = factor dependent upon type of refrigerant¹. (See Table 1)

D = outside diameter of vessel in feet (m).

L = length of vessel in ft. (m).

Table 1

Refrigerant.....	Value of f
When used on the low side of a limited-charge cascade system (Values in parentheses are metric):	
R-23, R-170, R-744, R-1150, R-508A, R-508B.....	1.0 (0.082)
R-13, R-13B1, R-503.....	2.0 (0.163)
R-14.....	2.5 (0.203)

Other applications:

R-718.....	0.2 (0.016)
R-717.....	0.5 (0.041)
R-11, R-32, R-113, R-123, R-142b, R-152a, R-290, R-600, R-600a, R-764.....	1.0 (0.082)
R-12, R-22, R-114, R-124, R-134a, R-401A, R-401B, R-401C, R-405A, R-406A, R-407C, R-407D, R-407E, R-409A, R-409B, R-411A, R-411B, R-411C, R-412A, R-414A, R-414B, R-500, R-1270.....	1.6 (0.131)
R-143a, R-402B, R-403A.....	2.0 (0.163)
R-407A, R-408A, R-413A.....	2.0 (0.163)
R-115, R-402A, R-403B, R-404A, R-407B, R-410A, R-410B, R-502, R-507A, R-509A.....	2.5 (0.203)

Example: What is the required discharge capacity of a pressure-relief valve to be used on an R-22 receiver that is 14" in diameter and 42" long having a design working pressure of 320 psi?

Solution: D = 1.167 ft., L = 3.5 ft., and f = 1.6 from Table 1:

$$C = fDL = 1.6 \times 1.167 \times 3.5$$

$$C = 6.5 \text{ lbs. air/min.}$$

In other words, under the conditions listed above, a receiver of this size requires a pressure-relief valve with a minimum discharge capacity of 6.5 pounds of air per minute at a pressure setting of 320 PSIG.

Pressure-Relief Valve Settings

All pressure-relief valves are rated according to their discharge capacity either in pounds or air per minute or kg/sec. at a given pressure setting. Under the ANSI/ASHRAE 15 Standard, pressure-relief valves shall start to function at a pressure not to exceed the design pressure of the parts of the system protected.

Generally, a pressure-relief valve may be set so that its initial leak is 100% of the design working pressure of the pressure vessel, regardless of the type of refrigerant used. The method of determining set pressure is outlined in Section 9.2 of the ANSI/ASHRAE Standard 15.

General Regulations and Recommendations

1. Pressure-relief valves are installed in a refrigeration system primarily to protect the receiver or other pressure vessel in the event of a fire or any other emergency high-pressure conditions. Fuse plugs protect only in the event of fire.

2. All systems must have a pressure-relief valve or a fuse plug installed in order to comply with the ANSI/ASHRAE Standard 15.

3. Pressure vessels with an internal gross volume of 3 ft.³ (0.085 m³) or less shall use one or more pressure-relief devices or a fusible plug.

Note: Local codes may require pressure-relief valves on receivers smaller than 3 ft.³.

4. Pressure vessels of more than 3 ft.³ (0.085 m³) but less than 10 ft.³ (0.285 m³) internal gross volumes shall use one or more pressure-relief devices. Fusible plugs are not permitted and should not be used.

5. Pressure vessels of 10 ft.³ (0.285 m³) or more internal gross volume use a single rupture member or dual pressure-relief valves when discharging to the atmosphere. Dual pressure-relief valves are installed with a three-way valve to allow testing or repairs (See Superior 3155W Series Valves). A three-way valve used in conjunction with the dual pressure-relief valves is not considered a stop valve.

6. Fuse plugs are temperature responsive relief devices only, and for all practical purposes, can only be considered as protection for the receiver of the system in cases of fire when the fire is in the immediate vicinity of the fuse plug.

7. Superior recommends the use of spring-loaded pressure-relief devices, such as our four series of pressure-relief valves. They are pressure sensitive and add an additional protection against abnormal system pressures.

8. Superior pressure-relief valves are approved and tested as required by Section VIII, Division 1 of the ASME Boiler and Pressure Vessel Code. All valves have pertinent data marked on the side of the valve body as required by the ASME Boiler and Pressure Vessel Code.

9. The pressure-relief valve set pressure cannot be higher than the design working pressure of the pressure vessel it is protecting, but, if conditions permit, the pressure-relief valve set pressure should be at least 25% higher than the maximum normal operating pressure.

10. All pressure-relief valves installed on the high side must be in a vapor space as near to the receiver as practical. Stop valves cannot be placed in the line between the pressure-relief valve and the pressure vessel it is protecting. In general, the pressure-relief valve should be installed directly to the receiver above the liquid level or as near to the inlet of the receiver as practical. All pipe and fittings between the pressure-relief valve and the parts of the system it protects must have at least the same diameter of the pressure-relief valve inlet diameter.

11. The size of discharge pipe from a pressure-relief valve must not be less than the outlet size of the pressure-relief valve. See ANSI/ASHRAE Standard 15 for requirements and guidelines on discharge piping.

12. Prior to installation or during pressure vessel testing, Superior pressure-relief valves should not be discharged. Any dirt in the system may imbed in the seat and prevent the pressure-relief valve from resealing properly.

13. The statements in this document reflect and are taken directly from ANSI/ASHRAE Standard 15-1994 and ANSI/ASHRAE Addendum 15c-2000. Please consult these standards for any additional information.