

What's in the Box

1. Stem Clamp
2. Handlebar
3. Frame
4. Seat
5. Seat Clamp
6. Suspension
7. Front Tire
8. Rear Tire
9. Charger
10. Charging Cable
11. Key

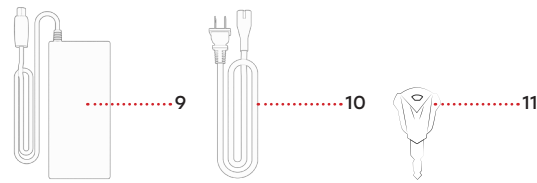
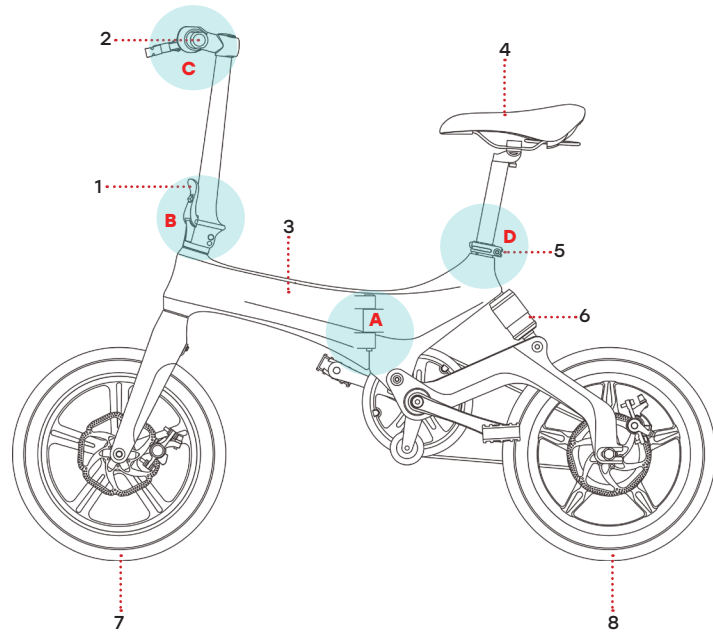

Specs & Features

- Unfolded Dimensions: 53" x 22" x 43.5"
- Folded Dimensions: 30.5" x 17" x 25.5"
- Weight Limit: 265 lb
- Product Weight: 41 lb
- Recommended Age: 12+
- Tire Size: 16"
- Max Speed: Up To 16 mph
- Max Range: Up To 25 Miles
- Battery: 36V, 5.2Ah Lithium-Ion
- Motor: 250W Hub Motor
- Charger: UL 110-240V
- Charge Time: Up To 4 Hours
- Climbing Angle: Up To 15°

1. Get Started

1.1 Unfolding the Frame (A)

Swing the Handlebar and Front Tire forward.

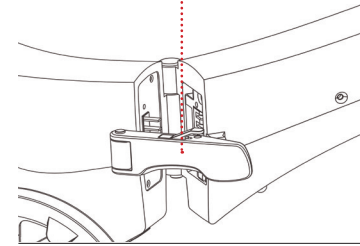

Press the Frame Locking Lever in to lock.

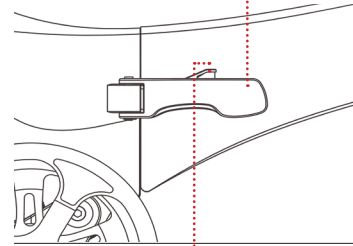

Note: To fold, press this button in when opening the Locking Lever.

1.2 Unfolding the Stem (B)

Slowly lift the Stem up

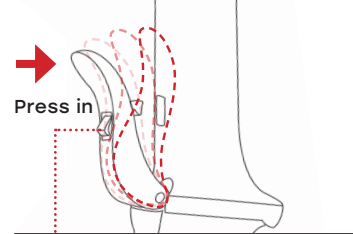
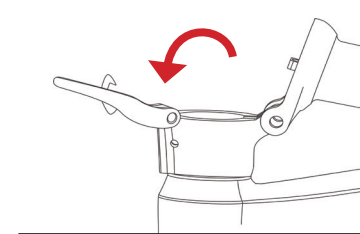

Note: To fold, press this button in when opening the Locking Lever.

1.3 Unfolding the Pedals

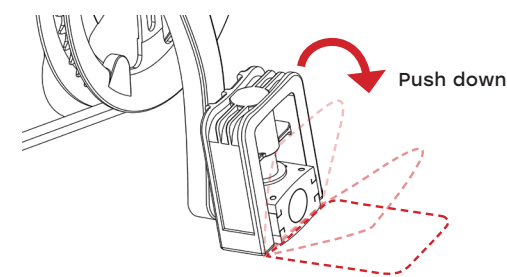

Note: Reverse these steps to fold the Metro.

1.4 Attaching the Handlebar (C)

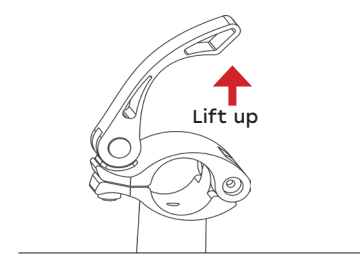

Place Handlebar in Clamp

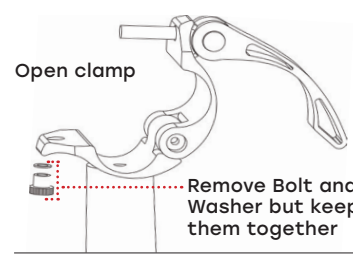
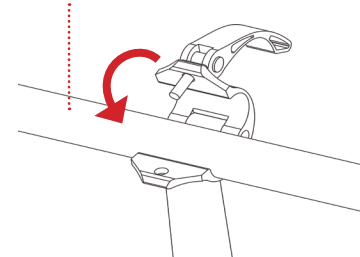

Open clamp

Remove Bolt and Washer but keep them together

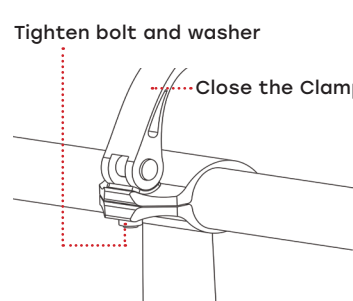

Tighten bolt and washer

Close the Clamp

1.5 Attaching the Seat (D)

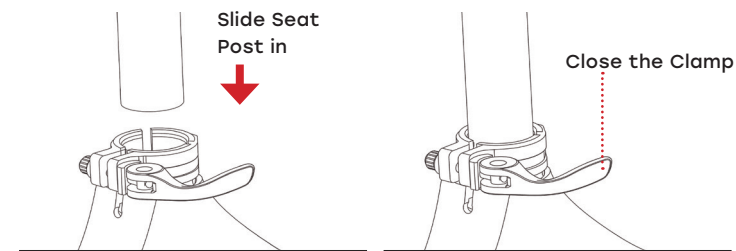

*Adults must assist children in the initial adjustment procedures to fold/unfold product and adjust seat height.

1.6 Charging the Battery

- Only use the included charger.
- Plug the charger into the wall before the Charging Port.
- Don't turn on the Metro while it's charging.
- Charge the battery until it is fully charged - up to 4 hours.
- Replace the cover over the Charging Port when done.

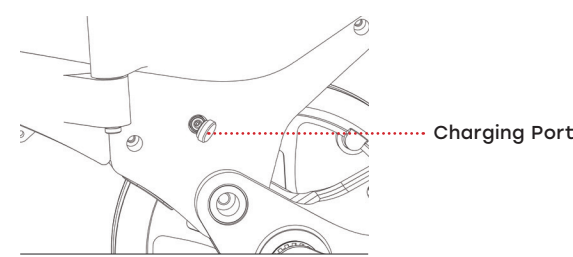

1.7 Removing the Battery

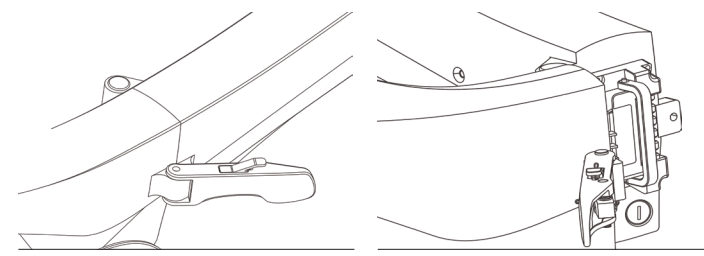

Open the frame.

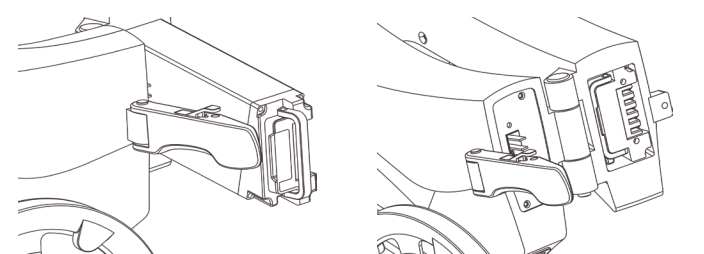

Slide the battery out.

Slide battery in all the way and lock it.

2. Make Moves

2.1 Riding the Metro

- Before each ride, make sure all clamps and locking levers are secure. Check whether the Frame, Handlebar, and Seat are secure.
- Use the throttle gently until you get used to it.
- Use the brake slowly to avoid stopping abruptly or losing control.
- Make your turns slowly and cautiously, and give yourself stopping distance



2.2 LCD Display

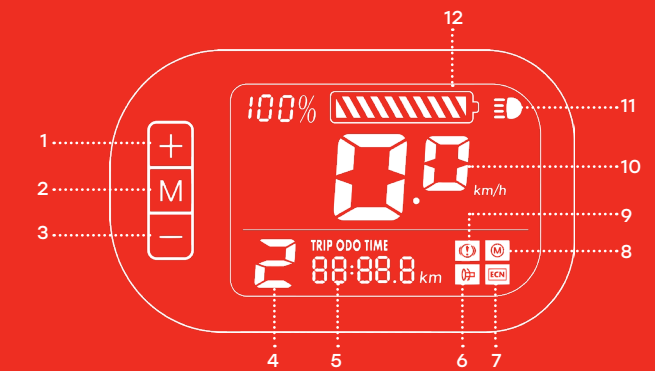

1. Up Button
2. Power Button
3. Down Button
4. Pedal Assist Level
5. Odometer
6. Throttle Problem Indicator
7. Controller Problem Indicator
8. Motor Problem Indicator
9. Brake Indicator
10. Current Speed
11. Headlight On
12. Battery Power Level Indicator

Power Button (M) - Hold for 3 seconds to turn the LCD Display on or off. Press it quickly to flip through the trip distance, total distance, and time spent riding.

Up Button (+) - Hold for 3 seconds to turn the Headlight on and off. Press it quickly to increase the pedal assist level.

Down Button (-) - Press it to decrease the pedal assist level.

Pedal Assist Mode:

| Lights | 0 | 1 | 2 | 3 |
|-----------|-------|-------|--------|--------|
| Max Speed | 6 mph | 8 mph | 12 mph | 16 mph |

Please Note: Images may not reflect exact appearance of actual product.

Care & Maintenance

RIDING RANGE

The maximum range is up to 25 miles. However, many factors will affect how far you can go per charge:

- Driving Surface: A smooth, flat surface will increase driving distance.
- Weight: More weight means less distance.
- Temperature: Ride, charge, and store the Metro above 50°F.
- Maintenance: Timely battery charging and maintenance will increase driving distance.
- Speed and Driving Style: Frequent starting and stopping will reduce driving distance.

CLEANING THE METRO

To clean the Metro, carefully wipe with a damp cloth, then dry with a dry cloth. Do not use water to clean the Metro, as the electrical and electronic systems may get wet, resulting in personal injury or malfunction of the Metro.

BATTERY

- Keep away from fire and excessive heat.
- Avoid intense physical shock, severe vibration, or impact.
- Protect from water or moisture.
- Do not disassemble the Metro or its battery.
- If there are any issues with the battery, please contact Jetson Customer Support.

STORAGE

- Fully charge the battery before storing. The battery should be fully charged once a month after this.
- Cover the Metro to protect against dust.
- Store the Metro indoors, in a dry place and at a suitable temperature.

Remember to be safe and most importantly, have fun!

DISPOSAL OF USED BATTERY

 Battery may contain hazardous substances which could endanger the environment and human health. This symbol marked on the battery and/or packaging indicates that used battery shall not be treated as municipal waste. Batteries should be disposed of at an appropriate collection point for recycling. By ensuring the used batteries are disposed of correctly, you will help preventing potential negative consequences for the environment and human health. The recycling of materials will help to conserve natural resources. For more information about recycling of used batteries, please contact your local municipality waste disposal service.

Safety Warnings

- Before use, please read the user manual and safety warnings carefully, and make sure you understand and accept all the safety instructions. The user will be responsible for any loss or damage caused by improper use.
- Before use, check to confirm that any and all axle guards, chain guards, or other covers or guards are in place and in serviceable condition. Check that the tires are in good condition, inflated properly and have sufficient tread remaining. Check that all guards and pads are in proper place and in serviceable condition.
- Components shall be maintained and repaired in accordance with the manufacturer's specifications and using only the manufacturer's authorized replacement parts with installation performed by dealers or other skilled persons.
- Don't allow hands, feet, hair, body parts, clothing, or similar articles to come in contact with moving parts, wheels, or drive train, while the motor is running.
- This product should not be used by children or persons with reduced physical, sensory or mental capabilities, or lack of experience and knowledge, unless they have been given supervision or instruction (IEC 60335-1/A2:2006).
- Unsupervised children should not play with the product (IEC 60335-1/A2:2006).
- Adult supervision is required.
- Replace worn or broken parts immediately.
- The rider should not exceed 265 lb.
- Never use near motor vehicles.
- Avoid streets and surfaces with water, sand, gravel, dirt, leaves, and other debris. Wet weather impairs traction, braking, visibility and can affect the overall performance of the product.
- Avoid riding around flammable gas, steam, liquid, or dust that could cause fire.
- Do not ride at night.
- Only ride the product with adequate daylight conditions for visibility.
- Do not ride after drinking or taking prescription medication.
- Do not ride the product if you have had any head, back, or neck ailments, or prior surgeries to those areas.
- Do not carry items when riding.
- Never operate the product barefooted.
- Always wear shoes and keep shoelaces tied.
- Make sure your feet are always placed securely on the deck.
- Always wear protective equipment such as helmet, knee pads, and elbow pads.
- Always give way to pedestrians.
- Always comply with local traffic laws and regulations.
- Operators shall adhere to all of the manufacturer's recommendations and instructions, as well as comply with all laws and ordinances.
- Be alert to things in front and far away from you.
- Do not allow distractions when riding, such as answering the phone or engaging in any other activities.
- The product cannot be ridden by more than one person.
- When you ride the product along with other riders, always keep a safe distance to avoid a collision.
- When turning, be sure to maintain your balance.
- Riding with improperly adjusted brakes is dangerous and can result in serious injury or death.
- Applying brakes too hard or too suddenly can lock up a wheel, which could cause you to lose control and fall. Sudden or excessive application of the brake may result in injury or death.
- If the brake loosens, please adjust with the hexagon wrench, or please contact Jetson Customer Support.
- Do not ride without proper training. Do not ride at high speeds, on uneven terrain, or on slopes. Do not perform stunts or turn abruptly.
- The area that the product is to be operated should be safe and suitable for safe operation.
- Check whether all safety labels are in place and understood before riding.
- The owner shall allow the use and operation of the unit after a demonstration that such operators can understand and operate all components of the unit before use.
- We encourage you to highlight the product, for visibility, by using lighting, reflectors, and signal flags on flexible poles.
- Use caution when charging. Do not operate charger near flammable materials. Unplug charger and disconnect from scooter when not in use.
- Prolonged exposure to UV rays, rain and the elements may damage the enclosure materials, store indoors when not in use.
- When the battery is fully charged, stop charging and unplug the unit.

California Proposition 65

WARNING:

This product can expose you to a chemical such as Cadmium that is known to the state of California to cause cancer or birth defects or other reproductive harm. For more information go to www.p65warnings.ca.gov/product

MODIFICATIONS

Do not attempt to disassemble, modify, repair, or replace the product or any components of the unit without instruction from Jetson Customer Support. This will void any warranty, and can lead to malfunctions which may cause injury.

ADDITIONAL OPERATION CAUTIONS

Do not lift the product off the ground while it is on and the wheels are in motion. This can result in freely spinning wheels, which may cause injury to yourself or others nearby. Do not jump on or off the product, and do not jump while using it. Always check the battery charge before using.

This equipment has been tested and found to comply with the limits for a Class B digital device, pursuant to part 15 of the FCC Rules. This equipment complies with FCC radiation exposure limits set forth for an uncontrolled environment. This transmitter must not be co-located or operating in conjunction with any other antenna or transmitter. Operation is subject to the following two conditions: (1) This device may not cause harmful interference, and (2) this device must accept any interference received, including interference that may cause undesired operation.

JETSON

Metro Folding Electric Bike.

A guide for your ride.

Enjoying the ride?

Leave a review on ridejetson.com/reviews or share your photos with us online using the #RideJetson hashtag!

Questions? Let us know.

US | Canada 1-(888) 976-9904
UK +44 (0)33 0838 2551

Hours of Operation: 7 Days a Week, 10am-6pm
help@ridejetson.com

Jetson Electric
1 Rewe St.
Brooklyn, NY 11211
www.ridejetson.com



Follow us @ridejetson
#MakeMoves

