



Owner's Manual • Betriebsanleitung  
 Mode d'emploi • Instrucciones de uso  
 Istruzione per l'uso • Manual de proprietário  
 Gebruiksaanwijzing • Driftsvejledning  
 Bruksanvisning

# S-3

## Airless Spray Gun

3900 PSI Max. Operating Pressure  
 Stainless Steel Fluid Passages

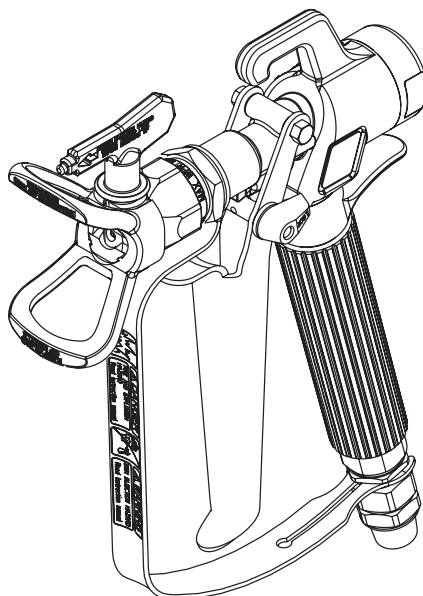

**For Professional Use Only**

English ..... p. 2  
 Deutsch..... p. 10  
 Français ..... p. 18  
 Español ..... p. 26  
 Italiano ..... p. 34

Português..... p. 42  
 Nederlands..... b. 50  
 Dansk.....s. 58  
 Svenska .....s. 66

# Safety Precautions



**Be safety-conscious! All local and national regulations governing ventilation, fire prevention, and operation must be observed.**



**HAZARD: Injection injury**

**A high pressure stream produced by this equipment can pierce the skin and underlying tissues, leading to serious injury and possible amputation. See a physician immediately.**

**DO NOT TREAT AN INJECTION INJURY AS A SIMPLE CUT! Injection can lead to amputation. See a physician immediately. Inform the physician of the type of coating material or cleaning agent with which the injury was caused.**

**The maximum operating range of the spray gun is 27 MPa / 3900 PSI fluid pressure.**

- NEVER aim the gun at any part of the body.
- NEVER allow any part of the body to touch the fluid stream. DO NOT allow body to touch a leak in the fluid hose.
- NEVER put hand in front of the gun. Gloves will not provide protection against an injection injury.
- Never point the spray gun at anyone else.
- ALWAYS lock the gun trigger, shut the pump off, and release all pressure before servicing, cleaning the tip or guard, changing tip, or leaving unattended. Pressure will not be released by turning off the motor. The PRIME/SPRAY valve must be turned to PRIME to relieve the pressure. Refer to the Pressure Relief Pressure described in the pump manual.
- ALWAYS keep the tip guard in place while spraying. The tip guard provides some protection but is mainly a warning device.
- ALWAYS remove the spray tip before flushing or cleaning the system.
- The paint hose can develop leaks from wear, kinking and abuse. A leak can inject material into the skin. Inspect the hose before each use.
- NEVER use a spray gun without a trigger lock and trigger guard in place and in good working order.
- All accessories must be rated at or above the maximum operating pressure range of the airless sprayer. This includes spray tips, extensions, and hose.



**HAZARD: Explosion hazard due to incompatible materials  
Will cause severe injury or property damage.**

- Do not use materials containing bleach or chlorine.
- Do not use halogenated hydrocarbon solvents such as bleach, mildewcide, methylene chloride and 1,1,1 - trichloroethane. They are not compatible with aluminum.
- Contact your coating material supplier about the compatibility of material with aluminum.



**HAZARD: General**

**This product can cause severe injury or property damage.**

- Read all instructions and safety precautions before operating equipment.
- Never spray near sources of ignition; e.g. open flames, cigarettes — also cigars and pipes are sources of ignition —, sparks, hot wires and hot surfaces, etc.
- Wear respiratory equipment when spraying. The operator must be provided with a protective mask. In order to prevent work related illness, the manufacturer's regulations for the materials, solvents, and cleaning agents used must be observed when preparing, working with and cleaning the unit. Protective clothing, gloves, eyewear, and, in certain cases, protective skin cream are necessary to protect the skin.
- Follow the coating material and solvent manufacturer's warnings and instructions.
- Extraction equipment should be installed by the user in accordance with local regulations.
- The objects being sprayed must be earthed.
- Before each use, check all hoses for cuts, leaks, abrasion or bulging of cover. Check for damage or movement of couplings. Immediately replace the hose if any of these conditions exist. Never repair a paint hose. Replace it with another grounded high-pressure hose.
- Pulling the trigger causes a recoil force to the hand that is holding the spray gun. The recoil force of the spray gun is particularly powerful when the tip has been removed and a high

pressure has been set on the airless high-pressure pump. Therefore, when cleaning without tip set the pressure control valve to the lowest pressure.

- Use only manufacturer authorized parts. User assumes all risks and liabilities when using parts that do not meet the minimum specifications and safety devices of the spray gun manufacturer.



## EXPLOSION PROTECTION IDENTIFICATION

### X marking:

The spray gun corresponds with Ex II 2G X and is, in accordance with Directive 94/9/EEC (Atex 100a), suitable for use in explosion-hazardous areas—as of type Zone 1. Under certain circumstances, the unit itself may cause the Zone 1 condition to be in effect.

Any static-electricity discharge from the spray gun is to be diverted to the grounded high-pressure pump via the conductive high-pressure hose as stipulated.

The maximum surface temperature corresponds to the permissible material temperature. This and the permissible ambient temperature can be found in the Technical Data.

To avoid the generation of machine sparks, prevent impact stresses and any work on the unit with tools in the explosion-hazardous area.

## Residual risks

Residual risks are risks, which cannot be excluded, even when equipment is used for the intended purpose. In such cases the applicable areas of the actual residual risks will be pointed out using warning and/or prohibition signs.

Risk	Source / Cause	Impact	Preventative measures	Can occur during:
Injection injury	Atomized, high pressure stream of fluid	Severe injury or amputation	NEVER aim the gun at any part of the body	Setup, Operation
Explosion or fire	Static electricity or sparks	Severe injury	Use well ventilated area Ground the spray gun	Operation
Hazardous vapors	Hazardous vapors from spray material	Severe injury	Use well ventilated area Use mask	Operation

## Technical Data

Max. operating pressure	27 MPa (3900 PSI)
Material inlet thread size	M16 x 1.5 (NPSM 1/4")
Diffuser thread size	7/8 - 14 UN-2A
Wetted parts material	High-grade stainless steel, urethane, polyethylene, nylon, hard metal
Operating temperature range	5°C to 40°C (40°F to 104°F)
Maximum material temperature	43°C (109°F)
Maximum sound output	81 dB(A)*
Weight	590 g (1,3 lb.)

\* Measurement location: 0.5 m away from the coating surface, 0.5 m behind the spray gun, spray pressure 12 MPa, tip size 0.021

## Introduction

This airless spray gun is to be used for the high pressure atomization of liquid coating materials.

## Using the Gun Trigger Lock

Always engage the gun's trigger lock when the gun is not in use.

1. To lock the trigger, rotate the trigger lock backwards until it stops.
2. To unlock the trigger, rotate the trigger lock forward until it is vertical.

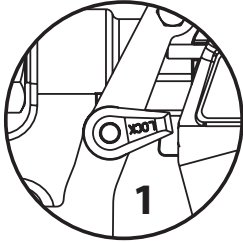

Gun locked (gun will not spray)

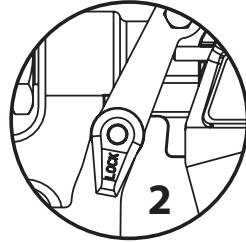

Gun unlocked (gun will spray)

## Setup



**Never attempt to assemble, change, or clean the gun, tip, or tip guard without first relieving pressure from the spray system. Follow the "Pressure Relief Procedure" in the sprayer's Owner's Manual.**



**Always use a tip safety guard for added protection against injection. Beware that the guard alone will not prevent injection. Never cut off tip guard! Always engage gun trigger lock when the gun is not in use. Before servicing equipment, consult Owner's Manuals and follow all warnings.**

1. Set up the sprayer. Refer to the instructions in the sprayer's Owner's Manual.
2. Attach a grounded, airless spray hose to the material inlet on the gun. Using two wrenches (one on the gun and one on the hose), tighten securely.
3. With the tip and tip guard off the gun, start the sprayer. Flush and prepare the spray system according to the sprayer's Owner's Manual. Inspect the spray system to make sure that all fittings are secure and that there are no leaks.
4. Perform the "Pressure Relief Procedure" described in the sprayer's Owner's Manual.
5. Using a pen or similar object, insert the tip seal (3) and seal (4) into the back of the tip guard (2). Press in for final adjustment.
6. Insert the tip (1) into the slot on the tip guard.

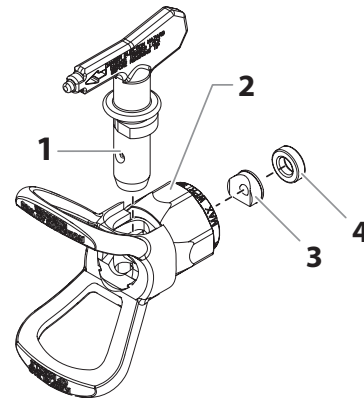

7. Thread the tip guard onto the gun. Position the tip guard in the desired spraying position, then tighten securely.



**The arrow on the tip handle should be pointing in the forward direction for spraying.**

## Operation

1. Make sure the arrow on the tip handle is pointing in the forward direction for spraying.
2. Start the sprayer. Refer to the instructions in the sprayer's Owner's Manual.
3. Adjust the fluid pressure on the sprayer until the spray is completely atomized. Always spray at the lowest pressure necessary to get the desired results.



**The spray tip determines the size of spray pattern and coverage. When more coverage is needed, use a larger tip instead of increasing fluid pressure.**

4. To clear a clogged tip:
  - a. Rotate the tip 180° so that the arrow on the tip handle is pointing opposite the spray direction.
  - b. Trigger the gun once so that the pressure can blow the clog out.



**Attention**

**Never pull the trigger more than once at time with the tip in the reverse position.**

- c. Continue this procedure until the tip is clear of the clog.

## Changing a Tip

Tips can be removed and replaced easily without disassembling the gun.



**Never attempt to change or clean the tip or tip guard without first performing the "Pressure Relief Procedure."**

1. Perform the "Pressure Relief Procedure" described in the sprayer's Owner's Manual.
2. Remove the tip from the slot on the tip guard.
3. Insert the new tip into the slot on the tip guard. The arrow on the tip handle should be pointing in the forward direction for spraying.

## Removing the Seal and Tip seal

1. Remove the tip and tip guard from the spray gun.
2. Remove the seal and tip seal from the back of the tip guard.

## Identifying Tip Sizes

To identify tip sizes, use the following formula. A "517" tip size will be used in this example.

The first digit multiplied by two represents the size of the spray pattern when spraying 12" away from the work surface:

$$5 \times 2 = 10" \text{ spray pattern}$$

The second two digits represent the diameter of the orifice on the tip:

$$17 = .017" \text{ orifice}$$



**Worn spray tips will adversely affect the spray pattern and result in reduced production, poor finish, and wasted material. Replace worn tips immediately.**

## Cleanup

Maintaining a clean gun is important to ensure trouble-free operation. Flush the gun after each use and store in a dry location. Do not leave the gun or any of its parts in water or solvents.



**Special cleanup instructions for use with flammable solvents:**

- Always flush spray gun preferably outside and at least one hose length from spray pump.
- If collecting flushed solvents in a one gallon metal container, place it into an empty five gallon container, then flush solvents.
- Area must be free of flammable vapors.
- Follow all cleanup instructions.



**Attention**

**The sprayer, hose, and gun should be cleaned thoroughly after daily use. Failure to do so permits material to cake, seriously affecting the performance of the unit.**



**Always spray at minimum pressure with the tip and tip guard removed when using mineral spirits or any other solvent to clean the sprayer, hose, or gun. Static electricity buildup may result in a fire or explosion in the presence of flammable vapors. Hold the gun firmly against a metal container while flushing.**

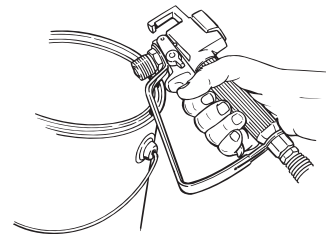

# Maintenance

Follow all safety precautions as described in the Safety Precautions section of this manual before proceeding.



Refer to the Parts List section in this manual for part identification.

## Replacing/Serviceing the Seal Assembly

If your spray gun leaks or spits at the tip when you release the trigger, the needle or seat is worn, damaged, or dirty and must be replaced or cleaned.



Never attempt to perform maintenance on the spray gun without first performing the "Pressure Relief Procedure."

1. Perform the "Pressure Relief Procedure" and disconnect the fluid hose from the gun.
2. Remove the end cap and the packing spring from the rear of the gun head.
3. Using a 3/8" socket, remove the packing seal assembly from the rear of the gun head.
4. Soak the removed parts in the appropriate solvent and wipe clean.
5. Inspect the parts for wear or damage and use new parts during reassembly of the gun, when necessary.



Lubricate all packings and moving parts before reassembly with a lithium-based grease.

6. Make sure the two retractor pins inside the gun head are still in the correct position.
7. Insert the packing seal assembly into the rear of the gun head and thread it by hand until it stops.
8. Using a 3/8" socket, tighten the packing seal assembly. Torque to 5 Nm (3.7 ft./lbs.).
9. Grease both ends of the packing spring and place it over the packing seal assembly in the gun head.
10. Place the end cap over the packing spring so that the pilot inside the end cap seats inside the packing spring.
11. Push the end cap toward the gun head while threading it into the gun head. Using a wrench, tighten the end cap securely.
12. Perform the "Adjusting the Packing Seal Assembly" procedure described below.

## Adjusting the Packing Seal Assembly



Proper adjustment of the packing seal assembly is essential to ensure positive shut-off when the trigger is released.

1. Insert an 1/8" hex wrench through the hole in the center of the end cap until it seats inside the packing seal adjustment screw.
2. Turn the packing seal adjustment screw until the ball on the packing seal assembly can be felt seating into position. Then, turn the screw 1/4 turn more for proper tension.

## Replacing/Removing the Filter

1. Pull the bottom of the trigger guard forward so that it comes loose from the handle assembly.
2. Loosen and remove the handle assembly from the gun head.
3. Pull the old filter out of the gun head.
4. Slide the new filter, tapered end first, into the gun head.
5. Place the handle seal into the gun head with the flat side of the seal toward the gun head.

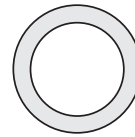

Flat side of handle seal (toward gun head)

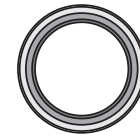

Bevelled side of handle seal (toward handle)

6. Thread the handle assembly into the gun head until secure.
7. Snap the trigger guard back onto the handle assembly.

## Filter Chart

Part Number	Application	Filter Type	Filter Color
0089960	Synthetic resin, enamels, clean varnishes, stains, azures	Extrafine	Red
0089959	Base coat enamels, primer enamels, fillers, marking paints, textured enamels	Fine	Yellow
0089958	Emulsions, latex paints, acrylic paints	Medium	White
0089957	Filler paints, large area surfaces	Coarse	Green

# Parts list

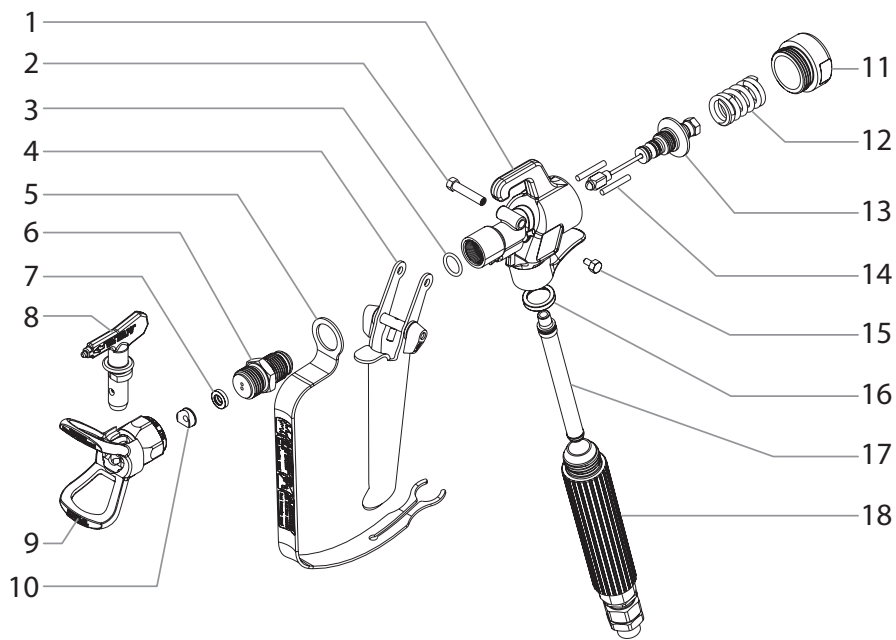

Item	Part #	Description
1	0502077	Gun head
2	0502068	Trigger screw, long
3	0502080	Diffuser o-ring
4	0502074	Trigger assembly, 4-finger gun
5	0296504	Trigger guard
6	550-257	Diffuser, 7/8", two hole, G-THD (incl. item 3)
7	651-020	Tip seal
8	662-517	Tip assembly (see accessory catalog for additional sizes)

Item	Part #	Description
9	0289228	Tip guard, G-THD
10	651-040	Tip seal retainer
11	0502159	End cap
12	0502054	Packing spring
13	550-264	Packing seal assembly
14	0502079	Retractor pin (2)
15	580-513	Trigger screw, short
16	560-038	Handle seal
17	0089958	Filter, medium
18	550-266	Handle/swivel assembly, 1/4 NPS
	0286707	S-3 label (not shown)
	550-275	Gun repair kit, G-THD two hole (includes items 3, 6, and 13)