

Safety Precautions

▲WARNING

IMPORTANT SAFETY INSTRUCTIONS

- A. SAVE THESE INSTRUCTIONS – To reduce the risks of fire or explosion, electrical shock, and the injury to persons, read and understand all instructions included in this manual. Be familiar with the controls and the proper usage of the equipment.**
- B. WARNING – To reduce the risk of fire or explosion:**
1. Do not spray flammable or combustible materials near an open flame, pilot lights or sources of ignition such as hot objects, cigarettes, motors, electrical equipment and electrical appliances. Avoid creating sparks from connecting and disconnecting power cords.
 2. For units intended for use with only water-based materials — Do not spray or clean with flammable liquids. For use with water-based liquids only.
 3. For units intended for use with only water-based or mineral spirit-type materials with a minimum flash point of 21°C (69.8°F) — Do not spray or clean with liquids having a flash point of less than 21°C (69.8°F). Flash point is the temperature at which a fluid can produce enough vapor to ignite.
 4. Paint or solvent flowing through the equipment is able to result in static electricity. Static electricity creates a risk of fire or explosion in the presence of paint or solvent fumes. All parts of the spray system, including the pump, hose assembly, spray gun and objects in and around the spray area shall be properly grounded to protect against static discharge and sparks. Use only conductive or grounded high-pressure airless paint sprayer hoses specified by the manufacturer.
 5. Verify that all containers and collection systems are grounded to prevent static discharge.
 6. Connect to a grounded outlet and use grounded extension cords. Do not use a 3 to 2 adapter.
 7. Do not use a paint or solvent containing halogenated hydrocarbons. Such as chlorine, bleach, mildewicide, methylene chloride and trichloroethane. They are not compatible with aluminum. Contact the coating supplier about compatibility of material with aluminum.
 8. Keep spray area well ventilated. Keep a good supply of fresh air moving through the area to keep the air within the spray area free from accumulation of flammable vapors. Keep pump assembly in well ventilated area. Do not spray pump assembly.
 9. Do not smoke in the spray area.
 10. Do not operate light switches, engines, or similar spark producing products in the spray area.
 11. Keep area clean and free of paint or solvent containers, rags, and other flammable materials.
 12. Know the contents of the paint and solvents being sprayed. Read all Material Safety Data Sheets (MSDS) and container labels provided with the paints and solvents. Follow the paint and solvent manufacturer's safety instructions.
 13. Place pump at least 25 feet (7.62 meters) from the spray object in a well ventilated area (add more hose if necessary). Flammable vapors are often heavier than air. Floor area must be extremely well ventilated. The pump contains arcing parts that emit sparks and can ignite vapors.
 14. Plastic can cause static sparks. Never hang plastic to enclose spray area. Do not use plastic drop cloths when spraying flammable material.

15. Fire extinguisher equipment shall be present and working.

▲WARNING

C. WARNING – To reduce the risk of skin injection:

HAZARD:

Injection injury – A high pressure fluid stream produced by this equipment can pierce the skin and underlying tissues, leading to a serious injury and possible amputation. See a physician immediately. DO NOT TREAT AN INJECTION AS A SIMPLE CUT.

1. Do not aim the gun at, or spray any person or animal.
2. Keep hands and other body parts away from the discharge. For example, do not try to stop leaks with any part of the body.
3. Always use the nozzle tip guard. Do not spray without the nozzle tip guard in place.
4. Only use a nozzle tip specified by the manufacturer.
5. Use caution when cleaning and changing nozzle tips. In the case where the nozzle tip clogs while spraying, ALWAYS lock gun trigger, shut pump off, and release all pressure before servicing, cleaning tip or guard, or changing tip. Pressure will not be released by turning off the motor. The PRIME/SPRAY valve handle must be turned to PRIME to relieve the pressure. Refer to PRESSURE RELIEF PROCEDURE described in the pump manual.
6. Do not leave the unit energized or under pressure while unattended. When the unit is not in use, turn off the unit and relieve the pressure in accordance with the manufacturer's instructions.
7. High-pressure spray is able to inject toxins into the body and cause serious bodily injury. In the event that injection occurs, seek medical attention immediately.
8. Check hoses and parts for signs of damage, a leak can inject material into the skin. Inspect hose before each use. Replace any damaged hoses or parts.
9. This system is capable of producing 3600 PSI / 25 MPa. Only use replacement parts or accessories that are specified by the manufacturer and that are rated a minimum of 3600 PSI. This includes spray tips, nozzle guards, guns, extensions, fittings, and hose.
10. Always engage the trigger lock when not spraying. Verify the trigger lock is functioning properly.
11. Verify that all connections are secure before operating the unit.
12. Know how to stop the unit and bleed pressure quickly. Be thoroughly familiar with the controls. Pressure will not be released by turning off the motor. The PRIME/SPRAY valve handle must be turned to PRIME to relieve the pressure. Refer to PRESSURE RELIEF PROCEDURE described in the pump manual.
13. Always remove the spray tip before flushing or cleaning the system.

▲WARNING

D. WARNING – To reduce the risk of injury:

1. Always wear appropriate gloves, eye protection, clothing and a respirator or mask when painting. Hazardous vapors – Paints, solvents, insecticides, and other materials can be harmful if inhaled or come in contact with body. Vapors can cause severe nausea, fainting or poisoning.
2. Do not operate or spray near children. Keep children away from equipment at all times.

- Do not overreach or stand on an unstable support. Keep effective footing and balance at all times.
- Stay alert and watch what you are doing.
- Do not operate the unit when fatigued or under the influence of drugs or alcohol.
- Do not kink or over-bend the hose. Airless hose can develop leaks from wear, kinking and abuse. A leak can inject material into the skin.
- Do not expose the hose to temperatures or pressures in excess of those specified by manufacturer.
- Do not use the hose as a strength member to pull or lift the equipment.
- Use lowest possible pressure to flush equipment.
- Follow all appropriate local, state and national codes governing ventilation, fire prevention and operation.
- The United States Government Safety Standards have been adopted under the Occupational Safety and Health Act (OSHA). These standards, particularly part 1910 of the General Standards and part 1926 of the Construction Standards should be consulted.
- Before each use, check all hoses for cuts, leaks, abrasion or bulging of cover. Check for damage or movement of couplings. Immediately replace hose if any of those conditions exist. Never repair a paint hose. Replace with a conductive high-pressure hose.
- Do not spray outdoors on windy days.
- Always unplug cord from outlet before working on equipment.

Setup

⚠ WARNING

Never attempt to assemble, change, or clean the gun, tip, or tip guard without first relieving pressure from the spray system. Follow the "Pressure Relief Procedure" in the sprayer's Owner's Manual.

⚠ WARNING

Always use a tip safety guard for added protection against injection. Beware that the guard alone will not prevent injection. Never cut off tip guard! Always engage gun trigger lock when the gun is not in use. Before servicing equipment, consult Owner's Manuals and follow all warnings.

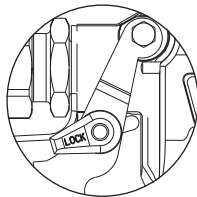

Trigger lock in locked position.

- Set up the sprayer. Refer to the instructions in the sprayer's Owner's Manual.
- Attach a grounded, airless spray hose to the material inlet on the gun. Using two wrenches (one on the gun and one on the hose), tighten securely.
- With the tip and tip guard off the gun, start the sprayer. Flush and prepare the spray system according to the sprayer's Owner's Manual. Inspect the spray system to make sure that all fittings are secure and that there are no leaks.
- Perform the "Pressure Relief Procedure" described in the sprayer's Owner's Manual.
- Using the arrowhead on the tip handle, insert the tip seal retainer and tip seal into the back of the tip guard. Press in for final adjustment.
- Insert the tip into the slot on the tip guard.
- Thread the tip guard onto the gun. Position the tip guard in the desired spraying position, then tighten securely.

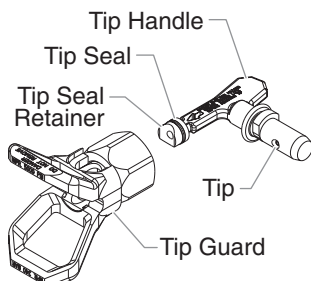

NOTE: The arrow on the tip handle should be pointing in the forward direction for spraying.

Operation

- Make sure the arrow on the tip handle is pointing in the forward direction for spraying.
- Start the sprayer. Refer to the instructions in the sprayer's Owner's Manual.
- Adjust the fluid pressure on the sprayer until the spray is completely atomized. Always spray at the lowest pressure necessary to get the desired results.

NOTE: The spray tip determines the size of spray pattern and coverage. When more coverage is needed, use a larger tip instead of increasing fluid pressure.

- To clear a clogged tip:
 - Rotate the tip 180° so that the arrow on the tip handle is pointing opposite the spray direction.
 - Trigger the gun once so that the pressure can blow the clog out.

⚠ CAUTION

Never pull the trigger more than once at time with the tip in the reverse position.

- Continue this procedure until the tip is clear of the clog.

Changing a Tip

Tips can be removed and replaced easily without disassembling the gun.

⚠ WARNING

Never attempt to change or clean the tip or tip guard without first performing the "Pressure Relief Procedure."

- Perform the "Pressure Relief Procedure" described in the sprayer's Owner's Manual.
- Remove the tip from the slot on the tip guard.
- Insert the new tip into the slot on the tip guard. The arrow on the tip handle should be pointing in the forward direction for spraying.

Removing the Tip Seal and Tip Seal Retainer

- Remove the tip from the tip guard.
- Insert the arrowhead of the tip handle through the front of the tip guard.
- Push the tip seal and tip seal retainer out through the back of the tip guard.

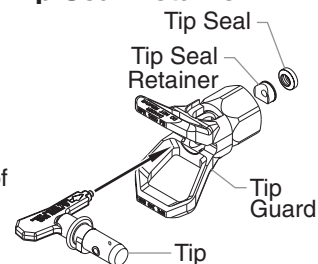

Identifying Tip Sizes

To identify tip sizes, use the following formula. A "517" tip size will be used in this example. The first digit multiplied by two represents the size of the spray pattern when spraying 12" away from the work surface:

$$5 \times 2 = 10" \text{ spray pattern}$$

The second two digits represent the diameter of the orifice on the tip:

$$17 = .017" \text{ orifice}$$

NOTE: Worn spray tips will adversely affect the spray pattern and result in reduced production, poor finish, and wasted material. Replace worn tips immediately.

Cleanup

Maintaining a clean gun is important to ensure trouble-free operation. Flush the gun after each use and store in a dry location. Do not leave the gun or any of its parts in water or solvents.



Special cleanup instructions for use with flammable solvents:

- Always flush spray gun preferably outside and at least one hose length from spray pump.
- If collecting flushed solvents in a one gallon metal container, place it into an empty five gallon container, then flush solvents.
- Area must be free of flammable vapors.
- Follow all cleanup instructions.



The sprayer, hose, and gun should be cleaned thoroughly after daily use. Failure to do so permits material to cake, seriously affecting the performance of the unit.



Always spray at minimum pressure with the tip and tip guard removed when using mineral spirits or any other solvent to clean the sprayer, hose, or gun. Static electricity buildup may result in a fire or explosion in the presence of flammable vapors. Hold the gun firmly against a metal container while flushing.



Maintenance



Follow all safety precautions as described in the Safety Precautions section of this manual before proceeding.

Replacing/Serviceing the Seal Assembly

If your spray gun leaks or spits at the tip when you release the trigger, the needle or seat is worn, damaged, or dirty and must be replaced or cleaned. Refer to the Parts List section in this manual for part identification.



Never attempt to perform maintenance on the spray gun without first performing the "Pressure Relief Procedure."

1. Disconnect the spray hose from the gun.
2. Remove the tip and tip guard.
3. With the trigger depressed, remove the diffuser from the front of the gun.
4. Remove the reversible carbide seat from the diffuser by gently tapping the diffuser on a hard, flat surface until the seat drops out.
5. Using a small flat-blade screwdriver, remove the gasket from the diffuser.
6. Using a 3/16" socket wrench, remove the ball valve assembly from the seal assembly.
7. Install the new ball valve assembly.
8. Reverse the carbide seat and place it on the ball valve assembly in the retaining nut housing.
9. Place the gasket around the carbide seat.
10. With the trigger depressed, thread the diffuser onto the retaining nut housing. Tighten with a wrench.

Serviceing the Needle Assembly

1. Perform steps 1–6 of the "Replacing/Serviceing the Seal Assembly."
2. Loosen and remove the lock nut, rear housing, and retractor pins from the back of the gun head.
3. Remove the seal assembly from the gun head by gently tapping on the back of the seal assembly.
4. Soak the parts in the appropriate solvent and wipe clean.
5. Inspect the parts for wear and replace, if necessary, during reassembly.

NOTE: Apply lithium grease to all packings and moving parts before reassembling.

6. Reverse steps 1–3 to reassemble.

Replacing/Removing the Filter

1. Pull down on the bottom of the trigger guard and swing it away from the handle.
2. Slide off the handle and unscrew the handle tube from the gun head.
3. Unscrew the filter from the gun head. If the filter breaks off during removal, use a small wood screw to remove remnants from the gun head.

NOTE: The filter has left-handed threads. Turn the filter clockwise to remove.

4. Screw the new or cleaned filter counterclockwise into the gun head.
5. Slide the handle tube over the filter and screw it into the gun head.
6. Slide the handle over the handle tube and reattach it to the gun head.
7. Secure the trigger guard back in position on the bottom of the handle.

Filter Chart

Part Number	Application	Filter Type	Color of Filter Body
500-200-15	Synthetic resin, enamels, clean varnishes, stains azures	Extrafine	red
500-200-10	Base coat enamels, primer enamels, fillers, marking paints, textured enamels	Fine	yellow
500-200-06	Emulsions, latex paints, acrylic paints	Medium	white
500-200-03	Filler paints, large area surfaces	Coarse	green

Accessories

Part #	Description
651-070	6" Gun Extension
651-071	12" Gun Extension
651-072	18" Gun Extension
651-073	24" Gun Extension
611-630	Gun Extension Swivel Head Assembly.
310-383-1	3' Pole Extension
310-386-1	6' Pole Extension
711-600	Pole Extension Swivel Head Assembly.
316-505	1/4" x 50' Airless Hose, 3300 PSI
310-110	Spray/Roll Accessories Kit
310-150	3' Pole with Inner Feed Roller
310-160	3' Pole with Spray Roller
002-XXX	Flat Tips
661-XXX	SC-6 Reversible Tips

Parts List

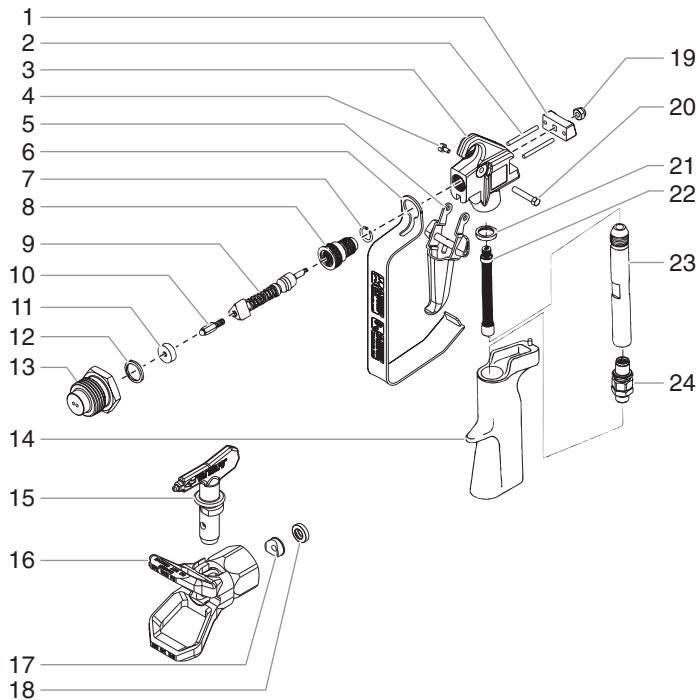

Item	Part #	Description	Quantity
1	580-003	Rear housing	1
2	580-025	Retractor pin	2
3	580-521	Gun head	1
4	580-513	Trigger screw, short	1
5	581-078	Trigger assembly	1
6	580-023	Trigger guard	1
7	584-008	Retaining ring	1
8	584-003	Retaining nut housing	1
9	584-024	Seal assembly	1
10	594-007	Ball valve assembly	1
11	594-033	Carbide seat (reversible)	1
12	594-006	Gasket	1
13	594-105	Diffuser	1
14	580-544	Handle	1
15	661-517	Tip assembly, SC6	1
16	661-012	Tip guard	1
17	651-040	Tip seal retainer	1
18	651-020	Tip seal	1
19	226-001	Lock nut	1
20	580-512	Trigger screw, long	1
21	560-038	Handle seal	1
22	500-200-06	Filter, medium	1
23	584-535	Handle tube	1
24	580-530	Swivel	1
	313-2435	Label, LX-80 Platinum	
	594-040	Ball valve kit (includes items 10–12)	
	584-045	Repair kit (includes items 9–12 and 19)	

Warranty

Titan Tool, Inc., (“Titan”) warrants that at the time of delivery to the original purchaser for use (“End User”), the equipment covered by this warranty is free from defects in material and workmanship. With the exception of any special, limited, or extended warranty published by Titan, Titan’s obligation under this warranty is limited to replacing or repairing without charge those parts which, to Titan’s reasonable satisfaction, are shown to be defective within twelve (12) months after sale to the End User. This warranty applies only when the unit is installed and operated in accordance with the recommendations and instructions of Titan.

This warranty does not apply in the case of damage or wear caused by abrasion, corrosion or misuse, negligence, accident, faulty installation, substitution of non-Titan component parts, or tampering with the unit in a manner to impair normal operation.

Defective parts are to be returned to an authorized Titan sales/service outlet. All transportation charges, including return to the factory, if necessary, are to be borne and prepaid by the End User. Repaired or replaced equipment will be returned to the End User transportation prepaid.

THERE IS NO OTHER EXPRESS WARRANTY. TITAN HEREBY DISCLAIMS ANY AND ALL IMPLIED WARRANTIES INCLUDING, BUT NOT LIMITED TO, THOSE OF MERCHANTABILITY AND FITNESS FOR A PARTICULAR PURPOSE, TO THE EXTENT PERMITTED BY LAW. THE DURATION OF ANY IMPLIED WARRANTIES WHICH CANNOT BE DISCLAIMED IS LIMITED TO THE TIME PERIOD SPECIFIED IN THE EXPRESS WARRANTY. IN NO CASE SHALL TITAN LIABILITY EXCEED THE AMOUNT OF THE PURCHASE PRICE. LIABILITY FOR CONSEQUENTIAL, INCIDENTAL OR SPECIAL DAMAGES UNDER ANY AND ALL WARRANTIES IS EXCLUDED TO THE EXTENT PERMITTED BY LAW.

TITAN MAKES NO WARRANTY AND DISCLAIMS ALL IMPLIED WARRANTIES OF MERCHANTABILITY AND FITNESS FOR A PARTICULAR PURPOSE WITH RESPECT TO ACCESSORIES, EQUIPMENT, MATERIALS OR COMPONENTS SOLD BUT NOT MANUFACTURED BY TITAN. THOSE ITEMS SOLD, BUT NOT MANUFACTURED BY TITAN (SUCH AS GAS ENGINES, SWITCHES, HOSES, ETC.) ARE SUBJECT TO THE WARRANTY, IF ANY, OF THEIR MANUFACTURER. TITAN WILL PROVIDE THE PURCHASER WITH REASONABLE ASSISTANCE IN MAKING ANY CLAIM FOR BREACH OF THESE WARRANTIES.



United States Sales & Service
1-800-526-5362
Fax 1-800-528-4826

107 Bauer Drive
 Oakland, NJ 07436
 www.titantool.com

Canadian Branch
1-800-565-8665
Fax 1-905-856-8496

200 Trowers Road, Unit 7B
 Woodbridge, Ontario L4L 5Z8

International
1-201-337-1240
Fax 1-201-405-7449

107 Bauer Drive
 Oakland, NJ 07436 USA