

Goldleaf  *Scientific*

Instruction Manual

Homogenising System X 1740

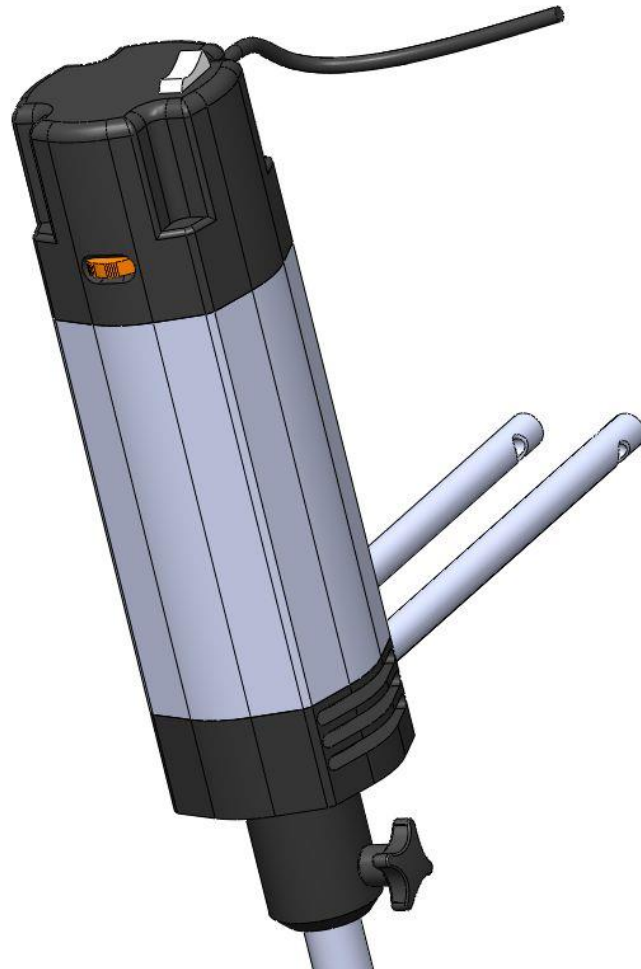

Content

1	User Instructions.....	5
1.1	Important Instructions for your safety.....	5
1.2	Danger symbols in this operating manual.....	6
1.2.1	Danger symbols:.....	6
1.2.2	Danger levels.....	6
1.2.3	Warning signs on the device.....	6
2	General safety warnings and instructions.....	7
3	Unpacking the Instrument.....	9
3.1	Scope of delivery.....	10
4	General Information.....	11
4.1	General Safety Information.....	11
4.2	Intended Use.....	11
4.3	Description Drive Unit X 1740.....	12
5	Set-up.....	13
5.1	Assembly of support rods.....	13
5.2	Attaching the drive unit to the U-stand.....	13
5.3	Description of a homogenising tool.....	14
5.4	Inserting the homogenizing tool.....	14
5.5	Electrical Connection.....	15
6	Operation X 1740.....	15
6.1	Description of the speed scale:.....	15
7	Exchanging the homogenizing shafts.....	16
7.1	Exchanging the generator.....	16
8	Maintenance and Cleaning.....	17
8.1	Cleaning the drive unit X 1740.....	17
8.2	Cleaning the homogenising tool.....	17
8.3	Maintenance of drive unit X 1740.....	17
8.4	Maintenance homogenizing tools.....	17
9	Dismantling, Transport and Storage.....	18
9.1	Dismantling.....	18
9.2	Transport and Storage.....	18
10	Disposal.....	18
11	Warranty and Liability.....	18
12	Technical Data.....	19

12.1	Technical Data X 1740	19
13	Repairs	19
13.1	Repair Return Form	20
25	Declaration of Conformity / Konformitätserklärung.....	36

This page is intentionally left blank

1 User Instructions

1.1 Important Instructions for your safety



- Every user must read and understand this manual completely before use. Failure to do so can result in serious injury or death.
- Comply with all safety and accident-prevention regulations applicable to laboratory work.
- Follow general instructions for hazard prevention and general safety instructions, e.g. wear protection clothing, eye protection and gloves.
- This operating manual is part of the product. Thus, it must always be easily accessible.
- This instruction sheet does not purport to address all of the safety problems which might result from the use of this device, chemicals, reagents, apparatus or equipment employed in any specific test or protocols. It is the responsibility of the user to consult their authorized safety advisors and establish appropriate health and safety practices and then determine the application of regulatory limitations prior to use.
- Enclose this operating manual when transferring the device to another place.
- If this manual is lost, please request another one. Please contact your dealer or:









Goldleaf Scientific

3300 Harrison st. suite 2
Riverside CA 92503
support@goldleaflabs.com
510-487-1390
www.goldleaflabs.com





1.2 Danger symbols in this operating manual

The safety instructions in this manual appear with the following danger symbols and danger levels:

1.2.1 Danger symbols:

 Hazard point	 Electrical shock
 Risk of fire	 Explosion
 Crushing	 Bio hazard
 Chemical hazard	 Material damage

1.2.2 Danger levels

 DANGER	Will lead to severe injuries or death
 WARNING	May lead to severe injuries or death
 CAUTION	May lead to light to moderate injuries
 NOTICE	May lead to material damage





1.2.3 Warning signs on the device









 **WARNING**

This symbol indicates that it is imperative to read and understand the instruction manual prior to operating the instrument. Please highlight points which require special attention in your field of application so they are not overlooked. Disregard of warnings may result in impairment of serviceability as well as in physical harm to the user.

2 General safety warnings and instructions

	<p>⚠ DANGER Risk of explosion.</p> <ul style="list-style-type: none">• Do not operate the device in the vicinity of highly flammable or explosive substances. The instrument is not explosion-proof.• Do not use this device for processing any substances which could generate an explosive atmosphere.• Do not use this device to process any explosive or highly reactive substances.• Do not use flammable or explosive substances near the instrument.
	<p>⚠ DANGER Electric shock as a result of penetration of liquid.</p> <ul style="list-style-type: none">• Do not allow any liquids to penetrate the inside of the housing• Switch off the device and disconnect the power plug before starting cleaning or disinfection work. The On/Off Switch on the device does not disconnect the device from the power source.• Use only closed tubes.• Only plug the device back in if it is completely dry, both inside and outside.
	<p>⚠ WARNING Risk from incorrect supply voltage</p> <ul style="list-style-type: none">• Only connect the device to voltage sources which correspondent to the electrical requirements on the type label.
	<p>⚠ WARNING Electric shock due to damage to device or mains cable</p> <ul style="list-style-type: none">• Only connect the device to the mains supply if the device and the mains cable are undamaged• Only use devices that have been properly installed or repaired.• In case of danger, disconnect the device from the mains supply by pulling the power plug from the mains socket or by using the isolating device intended for this purpose (e.g. emergency stop switch)
	<p>⚠ WARNING Lethal voltage inside the device</p> <ul style="list-style-type: none">• Do not open the device.• Ensure that the housing is always closed and undamaged so that no parts inside the housing can be contacted by accident.

	<ul style="list-style-type: none"> • The On/Off Switch on the device does not disconnect the device from the power source. Remove the plug from the AC power outlet to disconnect the instrument from the mains supply entirely. • Do not allow any liquids to penetrate the inside of the housing. • Repairs are only to be carried out by trained service technicians.
	<p>⚠WARNING Damage to health due to corrosive or aggressive chemicals</p> <ul style="list-style-type: none"> • Observe all markings on the reagent bottles. • Always check the instrument for leaks and air bubbles. Special attention should be directed to determine that all push-ons, threaded connections and suction tubes are firmly in place before beginning operation. <p>Leaking solutions may endanger persons and materials</p> <ul style="list-style-type: none"> • Use proper connecting vessels, protective clothing and gloves. • Avoid splashes • When dispensing, maintain a physical distance between the instrument and the body. • Dangerous and fuming chemicals must be dispensed in a fume hood. • Only employ the instrument for the purpose intended by the manufacturer, and particularly within the resistance limits of the instrument. If in doubt, contact your supplier, or the manufacturer's factory representative at the phone number shown at the front page of this operating instruction. • Always use the instrument in such a manner that neither the operator, nor any other person is endangered.
	<p>⚠WARNING Damages to health due to infectious liquids and pathogenic germs.</p> <ul style="list-style-type: none"> • When handling infectious liquids and pathogenic germs, observe the national regulations, the biological security level of your laboratory, the material safety data sheets and the manufacturer's application notes. • Wear personal protective equipment • For comprehensive regulations about handling germs or biological material of the risk group II or higher, please refer to the "Laboratory Biosafety Manual" in its respectively current valid version from the World Health Organisation
	<p>⚠WARNING Damage to health due to contaminated device and accessories</p> <p>In the following cases, sample material can be released:</p> <ul style="list-style-type: none"> - unstable tubes - smashed glass tubes - too high speed causes splashes

	<ul style="list-style-type: none"> • Only mix in stable tubes • Observe the nationally prescribed safety environment when working with hazardous, toxic and pathogenic samples. Pay particular attention to personal protective equipment (gloves, clothing, goggles, etc.), extraction, and the safety class of the lab. • Decontaminate the device and the accessories before storage and shipping.
	<p>▲WARNING Risk of fire</p> <ul style="list-style-type: none"> • Do not use this device to process any highly flammable liquids
	<p>▲CAUTION Poor safety due to inadequate fixing of the unit</p> <ul style="list-style-type: none"> • Ensure that the unit is firmly attached to a solid stand.
	<p>▲CAUTION Poor safety due to incorrect accessories and spare parts.</p> <p>The use of accessories and spare parts other than recommended by Goldleaf Scientific may impair the safety, function and precision of the device. Goldleaf Scientific cannot be held liable or accept any liability for damage resulting from the use of incorrect or non-recommended accessories and spare parts, or from the improper use of such equipment.</p> <ul style="list-style-type: none"> • Only use accessories and spare parts recommended by Goldleaf Scientific
	<p>▲CAUTION Crush hazard due to moving parts</p> <ul style="list-style-type: none"> • Do not replace any consumables as long as the device is running. • Do not open the coverage as long as the device is running

3 Unpacking the Instrument

Unpack the instrument carefully and check to see that it is not damaged. It is important that any damage incurred in transport to be recognized at the time of unpacking. Notify your carrier or forwarding agent immediately in case of such damage.

3.1 Scope of delivery

Please check that the package contains the following:

Type	Description	Part No.
X 1740	Homogenizing Drive Unit, 230 V	60408-0000 or
X 1740	Homogenizing Drive Unit, 115 V incl. 2 support rods Instruction Manual	60408-0001

Homogenising tools and accessories (to be ordered separately):

Tools	Description	Part No.	
T 30	Shaft, 20 mm diameter, without Generator	60414-0000	
	type F complete with generator	60427-000F	
	type N complete with generator	60427-000N	
	type V complete with generator	60427-000V	
G 30	Shaft, 20 mm diameter, without Generator	60415-0000	
	type F complete with generator	60428-000F	
	type M complete with knife generator	60428-000M	
	type N complete with generator	60428-000N	
T 40	Shaft, 20 mm diameter, without Generator	60414-0000	
	type F complete with generator	60414-000F	
	type N complete with generator	60414-000N	
	type V complete with generator	60414-000V	
G 40	Shaft, 20 mm diameter, without Generator	60415-0000	
	type F complete with generator	60415-000F	
	type M complete with knife generator	60415-000M	
	type N complete with generator	60415-000N	
DK 40 incl. baseplate U-stand incl. rod	Flow-through chamber with external cooling incl. short shaft G40 (N) platform overall dimensions: 692x371 mm, rod diameter: 27mm, length:1010mm	60429-0000	
		60494-0000	
	Special clamp	clamp to attach the unit to a stand	60495-0000
	Socket wrench	for all shafts	60471-0000
Rotor wrench	for shaft T/G 30	60476-0000	
Rotor wrench	for shaft T/G 40	60477-0000	

4 General Information

The homogenising drive unit X 1740 is designed in accordance with Safety Class II and built and tested in accordance with DIN EN 61010.

According to these regulations the unit is designed to meet the requirements for safe and correct operations. To maintain the proper safety and operational functions of the instrument the user should follow the instructions and safety guidelines in this manual.

4.1 General Safety Information



▲WARNING

If noise level exceeds 85 dB (A) at the work station operator must use ear plug and/or ear muffers.



▲WARNING

Wear ear protection should the noise level exceed 85dB(A).



▲WARNING

Ensure that the unit is firmly attached to a stand.



▲WARNING

Wear eye protection.



4.2 Intended Use

The X 1740 is a homogenizing system which in connection with a homogenizing tool produces emulsions and dispersions and is used in laboratories, universities and industries. For safe operation the unit has to be fixed to a stand.

4.3 Description Drive Unit X 1740

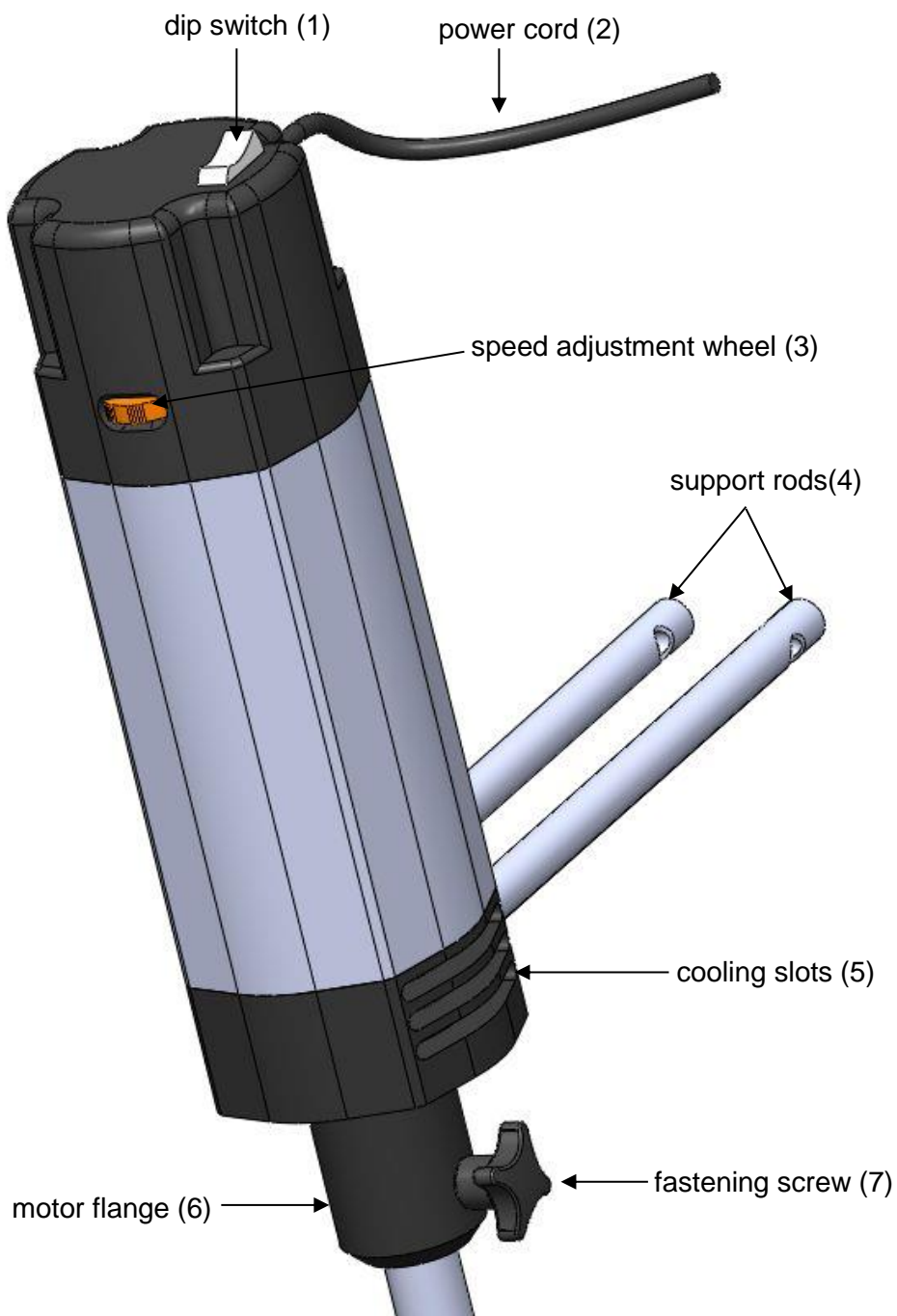

5 Set-up

5.1 Assembly of support rods

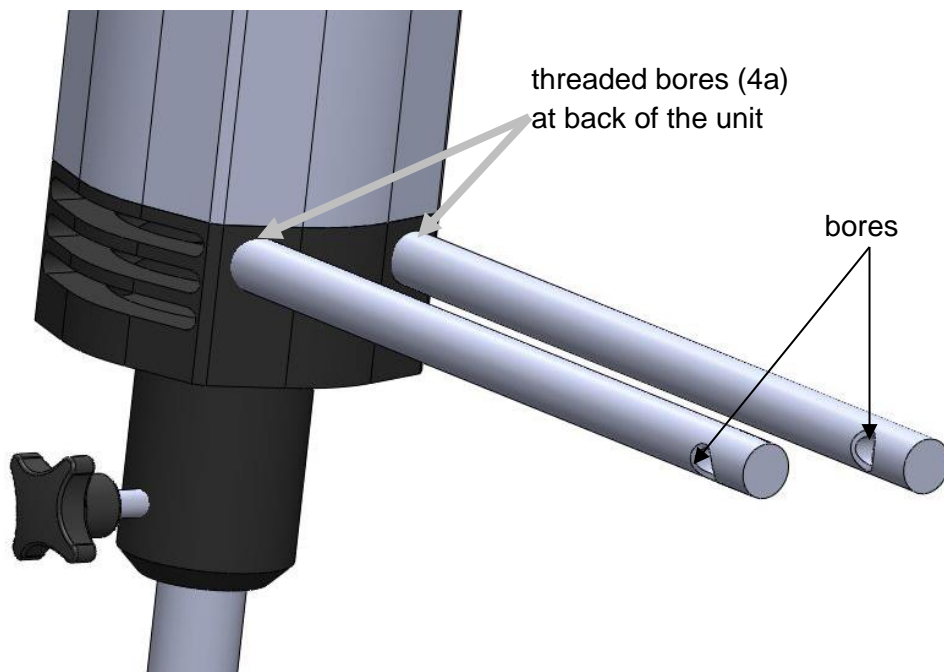

Screw the support rods (4) into the threaded bores (4a) at the back of the unit.

Insert a screw driver into the bores at the end of the support rods and firmly tighten the support rods by turning the screw driver to the right.

5.2 Attaching the drive unit to the U-stand



WARNING To ensure safe operation the drive units are mounted to the U-stand using the special clamp (8). Vibrations may loosen the fastening screws. Please check periodically whether all fastening screws are securely tight.

special clamp (8)

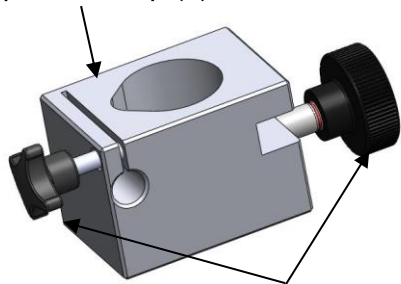

clamp screws (9)

- Attach special clamp (8) to the stand rod.
- Now attach the drive unit to the stand by inserting the support rods (6) into the free openings of the special clamp (8).
- Tighten clamp screws (9) of the special clamp (8).

5.3 Description of a homogenising tool



CAUTION

The generators have sharp edges. Handle with care. Risk of injuries!

The homogenizing tool comes always assembled. The connecting adapter (drive pin (10)) is located on the top of the shaft and is used to attach the shaft to the drive motor.

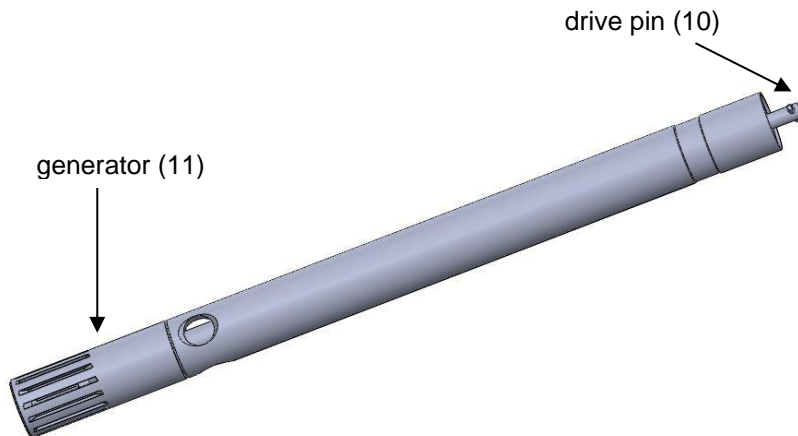

5.4 Inserting the homogenizing tool

When inserting the homogenising tool, make sure that the coupling fits well. This can be easily detected by the "click" that is heard when the coupling shaft has reached the end of the coupling slot of the motor. Securely fasten the fastening screw (7).

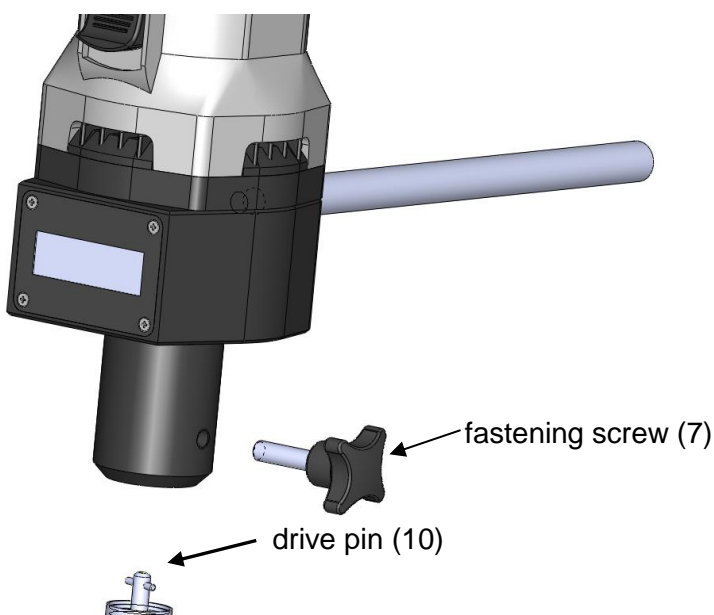

CAUTION

Never run homogenising tools dry as the bearings and gaskets will be damaged if the generator is not cooled by the medium. The distance between the homogenising tool and the vessel bottom should not be less than 10mm. The filling of the medium may not be less than about 55 mm. To avoid a vortex it is necessary to insert the dispersing shaft out of the center of the vessel. If these conditions are met the unit is ready

5.5 Electrical Connection



▲WARNING

When connecting the instrument to an AC power outlet, ensure that your local supply voltage matches that indicated on the instrument's rating plate.

On delivery, the units are supplied with an Euro plug EN 50075:1990, 2.5 A, 250 V. For North America, with a U.S. standard plug (NEMA 1, Type A) 10 A, 125 V.

When operating the instruments in countries with different AC plug systems use an approved adapter or have a qualified electrician replace the AC plug with an approved model suitable for the country of operation.



▲WARNING

The dip switch (1) is only single-pole and is thus not suitable for safely isolating the unit from the mains supply!



▲WARNING

Before connection the instrument to the mains ensure that the dip switch is set to the „OFF“- position.

6 Operation X 1740

The drive unit is turned on and off by means of the dip switch (1) at the motor housing.

- Dip switch position I: motor runs
- Dip switch position 0: motor off

With the speed adjustment wheel (3) the speed can be steplessly adjusted.

Before starting the unit make sure that

- the speed is set to the lowest speed
- the generator of the homogenising tool is inserted in the fluid. To avoid a vortex, it is necessary to insert the dispersing shaft out of the centre of the vessel.
- the vessel is protected against rotating, shaking or moving
- make sure that the air ventilation slots are always open, as this is necessary for cooling purposes

Start the unit always at the lowest speed and then gradually increase the speed to the desired level.

6.1 Description of the speed scale:

1	=	2500 rpm
2	=	7000 rpm
3	=	11000 rpm
4	=	15000 rpm
5	=	19000 rpm
6	=	23000 rpm

7 Exchanging the homogenizing shafts

Prior to exchange the homogenizing shaft disconnect the unit from the mains supply. Loosen the fastening screw (7) and firmly pull out the shaft by hand. It will disconnect easily. When inserting another shaft, make sure that the coupling fits well. This can be easily detected by the "click" that is heard when the coupling shaft has reached the end of the coupling slot of the motor. Do not forget to securely fasten the fastening screw (7).

7.1 Exchanging the generator

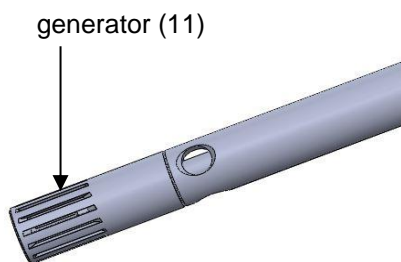

CAUTION

The generators have sharp edges. Handle with care. Risk of injuries!

To exchange the generator (rotor and stator = generator)(11) always take the shaft out of the motor drive unit as described above. For undoing the rotor, use the two special keys (to be ordered separately). The socket wrench is used to counter-hold the shaft, and the rotor wrench to undo the rotor. To exchange the stator, remember that the fastening thread is counter-clockwise. You will find further detailed descriptions in the instruction manual which comes with each homogenising tool.

NOTICE

Always unscrew the rotor first before unscrewing the stator.

8 Maintenance and Cleaning

8.1 Cleaning the drive unit X 1740

To clean the drive unit use only water with a detergent that contains tensides or use isopropyl alcohol for stubborn soiling.

8.2 Cleaning the homogenising tool



CAUTION

The generators have sharp edges. Handle with care. Risk of injuries!

To avoid clogging clean shaft, generator and in case of G-shaft the sealing parts after each use. This is done by operating it in a solvent which dissolves substance residues and is not harmful to the gasket. This is usually sufficient to clean the generator.

Chemical sterilization may be also a method. General-purpose disinfectants such as formalin, alcohol, etc. may be used. It is important to remove disinfectant residues with sterilized water.

NOTICE

Make sure that the bearings, O-rings and gaskets are resistant to solvents.

Sterilization with moist heat:

This denotes the use of a steam jet pressurized to 2 bars at 120°C.

8.3 Maintenance of drive unit X 1740



WARNING

Do not open the instrument. Repairs are only to be carried out by trained service technicians.

8.4 Maintenance homogenizing tools



CAUTION

The generators have sharp edges. Handle with care. Risk of injuries!

The gaskets in the homogenizing tools must be constantly monitored. In the event of leakage the suction effect of the rotating shaft can cause the medium to penetrate as far as the drive unit. If liquid emerges from the side hole at the top of the shaft tube stop work immediately and check the gaskets. The function of the generators depends on the condition of the sharp edges on the rotor and stator. These edges may be blunted very quickly in abrasive media, reducing the effectiveness of homogenizing.

9 Dismantling, Transport and Storage

9.1 Dismantling

1. Switch the unit off.
2. Disconnect it from the mains supply.
3. Remove any glass beakers and any other equipment around the drive unit.
4. Remove the homogenizing tool by loosening the fastening screw (7).
5. Loosen the special clamp and remove the clamp from the support rod.
6. Unscrew the support rods.
7. Now you may remove the instrument from the working area.

9.2 Transport and Storage

Prior to transport:

Switch the instrument off and proceed with dismantling as described under "Dismantling".

Place the instrument and its parts in its original packaging or another suitable container to protect it during transport. Close the packaging with adhesive tape.

Store the instrument in a dry environment. Please observe the specified conditions of the ambient (temperature and humidity).

Do not subject the instrument to mechanical shocks or vibration during transporting it.

In case you do not use the original packaging please mark the box with the following notes:

- Glass symbol (handle with care, fragile)
- Umbrella (keep dry)
- Content (list of content)
- Storage ambient:
 - Max. ambient temperature : RT to +40°C
 - Max. humidity: 80%

10 Disposal



Please dispose of used instruments and defective components at your local recycling collection point. Prior to disposal, sort according to materials: metal, glass, plastic, etc. Also be sure to dispose of the packing material in an environmental-friendly manner.

11 Warranty and Liability

The manufacturer agrees to either repair, or replace, at the manufacturer's discretion, any defects in materials or workmanship which develop within 24 months of the delivery of this product to the

original user. In the event of replacement, the replacement unit will be guaranteed for the remainder of the original twenty-four (24) months period.

If this product should require service, contact your local distributor or manufacturer for necessary instructions.

This guarantee will not apply if the defect or malfunction was caused by accident, neglect, unreasonable use or fitness for a particular purpose, which extend beyond the description and period set forth herein.

The manufacturer's sole obligation under this guarantee is limited to the repair or replacement of a defective product and the manufacturer shall not, in any event, be liable for any incidental or consequential damages of any kind, resulting from use or possession of the product.

	▲WARNING The user has to determine, if the instrument is suitable for his specific application. If there are any further queries, contact your local dealer or the manufacturer direct.
---	--

12 Technical Data

12.1 Technical Data X 1740

Type: X 1740	Specifications
Motor Power input	1800 Watt
Motor Power output	1200 Watt
Idle speed	2500 - 23000 rpm
Voltage	230 V/50 Hz or 115 V/60 Hz
Case dimensions	100 x 100 x 360 mm, WxDxH
Weight	4.7 kg incl. support rods
Permissible ambient temperature	5 - 40 °C
Permissible humidity	80 % RH

13 Repairs



▲WARNING When returning instruments for repair that have come into contact with hazardous substances, please:

Fill in attached "Repair Return Form"

Provide precise information on the relevant medium

Take protective measures to ensure the safety of our receiving and maintenance personnel

Mark the package as appropriate for hazardous materials.

13.1 Repair Return Form

CONTACT/USER INFORMATION

Contact:	Phone No.
Fax No.	Email:
Billing:	Shipping:
Company	Company
Address	Address

INSTRUMENT INFORMATION		
Model	Serial No.	
Please describe all problems/malfunctions		
Operating Conditions (please fill in if applicable)		
Ambient Temp.	Humidity	Speed
Load	Volume	Viscosity
Temperature in °C	Sample Temperature	Operating Time
Sample Description*		

*NOTE: If the instrument was exposed to hazardous material, it must be decontaminated BEFORE returning it to Goldleaf Scientific and an MSDS for hazardous material must be included with the instrument.

RETURN SHIPPING			
UPS <input type="checkbox"/>	Air Parcel Post <input type="checkbox"/>	Collect** <input type="checkbox"/>	Other** <input type="checkbox"/>

**Your account number is required for UPS collect respectively the address and contact of your preferred forwarder if you choose any other transport means.

PACKAGING INSTRUCTIONS TO RETURN AN INSTRUMENT FOR REPAIR
--

- ✓ Remove all accessories (e.g. homogeniser tools, stirring paddles) from the instrument
- ✓ Clean excess testing material off the instrument/accessory
- ✓ Include MSDS sheets for all hazardous materials used with this instrument
- ✓ Pack the instrument in its original box. If the box is not available, take care to wrap the instrument and accessories with enough material to support them.
- ✓ DO NOT send pedestal stand unless there is a problem with the upright rod, clamp or base. If there is a problem with the stand remove the upright rod from the base and individually wrap each item to avoid contact with the instrument. (Applicable for overhead stirrers and homogenisers.)
- ✓ Pack the instrument and related items in a strong box for shipping. Mark the outside of the box with handling instructions.

Example: "Handle with care" or "Fragile- Delicate Instrument" and send to:
Goldleaf Scientific, 3300 Harrison st suite 2 Riverside CA 92503