

Rotary Evaporator (Single/Dual Condenser Type)



Version: 2021



Introduction

This rotary evaporator is a new type of design developed by Goldleaf Scientific over many years of design and industry production experience. A rotary evaporator is mainly used to continuously distill a large amount of volatile solvents under reduced pressure and temperature. The basic principle of a rotary evaporator is vacuum distillation, that is, under reduced pressure, the distillation flask is continuously heated and rotated as the solvent is distilled.

Please refer to this instruction manual (operation manual) before using. If you have any questions, please feel free to contact us and we will do our best to serve you. We have glassblowing on site for quick repairs and a wide variety of additional replacement parts, repair services, and add-ons at www.goldleaflabs.com

New model upgrades include:

- More heating power
- Double condensers
- Double receiver flask

**Optional Solvent Injection Pre-heating System can increase distillation rate by up to 50%. Inquire for pricing and details.*

Goldleaf Scientific

| | |
|--|----|
| 1. Working principle and scope of application | 4 |
| 2. Precautions | 4 |
| 3. Structure and composition | 7 |
| 3.1. Outside view..... | 8 |
| 3.2. Operating Instructions for operating panel (Figure 6)..... | 12 |
| 3.3. Operation instructions..... | 13 |
| 3.4. Operation of over-temperature protector..... | 14 |
| 4. Installation | 15 |
| 4.1. Stripping..... | 15 |
| 4.2. Installation diagram of upright rod | 15 |
| 4.3. Installation diagram of three-way flask, rotating shaft, evaporating flask..... | 16 |
| 4.4. Installation diagram of main condenser, receiving flask and check valve..... | 18 |
| 4.5. Other parts installation..... | 20 |
| 5. Specification | 21 |
| 6. Operating instructions | 22 |
| 6.1. Preparation before operation..... | 22 |
| 6.2. Instructions for use | 22 |
| 6.3. Setting order of each function | 23 |
| 7. Troubleshooting | 24 |
| 8. Maintenance | 25 |
| 9. Packing List | 26 |

1. Working principle and scope of application

Rotary evaporator is mainly used for continuous distillation of a large number of volatile solvents under reduced pressure conditions. The basic principle of rotary evaporator is vacuum distillation, that is, under reduced pressure, the distillation flask is continuously heated and rotated as the solvent is distilled.

2. Precautions



Safety warning!

Dangerous (may result in serious loss of property or casualties)

The instrument must be grounded and away from sources of electromagnetic interference (must not be zero line or middle line for the ground);

1. Please use this product in the laboratory environment, the use and operation of this product must undergo a professional study or training, laboratory safety knowledge, and have some basic knowledge of physics, chemistry, biology, medical and other professional knowledge and related Laboratory skills.
2. Please comply with safety norms, personal safety and accident prevention and other related norms, especially in the vacuum!
3. Do not allow lengthen or shorten instrument power cable at will.
4. Do not refit this instrument, do not use for other purposes than the provisions of this product, if refit this instrument or used for other purposes may lead to electric shock or cause equipment failure;
5. This product is non-explosion-proof specifications, do not put in a place of environmental risk, if use in dangerous place will lead to fire and other accidents; Do not heat solvents under atmospheric pressure;
6. If flammable samples or organic solvents, please take care not to spill the solution.
7. The function or performance of the product, the host part need to rotate use in the high temperature water bath, at the same time, there are glass components in this product, the glass will split if the use is improper and cause accidental injury or accident.

Goldleaf Scientific

8. Do not disassemble the instrument. There is voltage or high temperature inside the instrument. If decomposition instrument will cause personal injury.



Warning (may cause property damage or personal injury)

1. Before use, please confirm the voltage and frequency of the power supply match the requirements of the instrument;
2. The instrument should use a separate power outlet, and confirm the plug, socket grounding good;
3. Do not allow to unplug the power plug under the operation of the instrument does not turn off the power switch;
4. Before use, please carefully check the equipment, accessories, especially glass components are damaged, do not use damaged parts;
5. The instrument is only suitable for the medium that does not react to the energy generated in the process to produce dangerous medium; at the same time, the material to be processed could not react with the energy generated by other ways, such as light to generate danger;
6. In the operation of this product need to wear safety glasses and appropriate protection devices, prohibit the use of non-heat-resistant, fragile and other safety-affecting containers and aids;
7. Shall not be repaired without authorization, commissioned by the company must be repaired by professionals;
8. Please use the correct method and supplies appliances for cleaning and maintenance of this product.

Note (may affect the service life of the instrument cause it could not work normally)

1. The product should be placed in a hard and firm plane, to keep it level;
2. Handling equipment, please hand support instrument base and hold the fuselage together with handling;
3. Water bath should be energized after inject water, not allowed to dry without water;
4. Glass should be hand gently, washed and dried;

Goldleaf Scientific

5. The use of grinding mouth instrument before installation should be evenly coated with a small amount of vacuum grease;
6. Expensive solution should be done first simulation test, confirm the instrument is applicable and then transferred to the normal application;
7. The product should be retained around the gap, to ensure that there is enough space above the instrument, the glass components may exceed the height of the instrument;
8. The product must be used under certain conditions of use;
9. To ensure that the instrument does not move due to vibration when opened;
10. To keep the use of the environment clean and dry, away from the heat source, a strong magnetic field, flammable or other similar magnetic products;
11. This product could not invade the liquid, must not move while using, must unplug the power cord when moving or cleaning;
12. After the work, turn off the switch, unplug the power plug;
13. Long-term non-use, please turn off the power switch, and unplug the power plug from the outlet.

3. Structure and composition

3.1 Rotary Evaporator Outside view

(This figure is only for reference, subject to the real thing!)

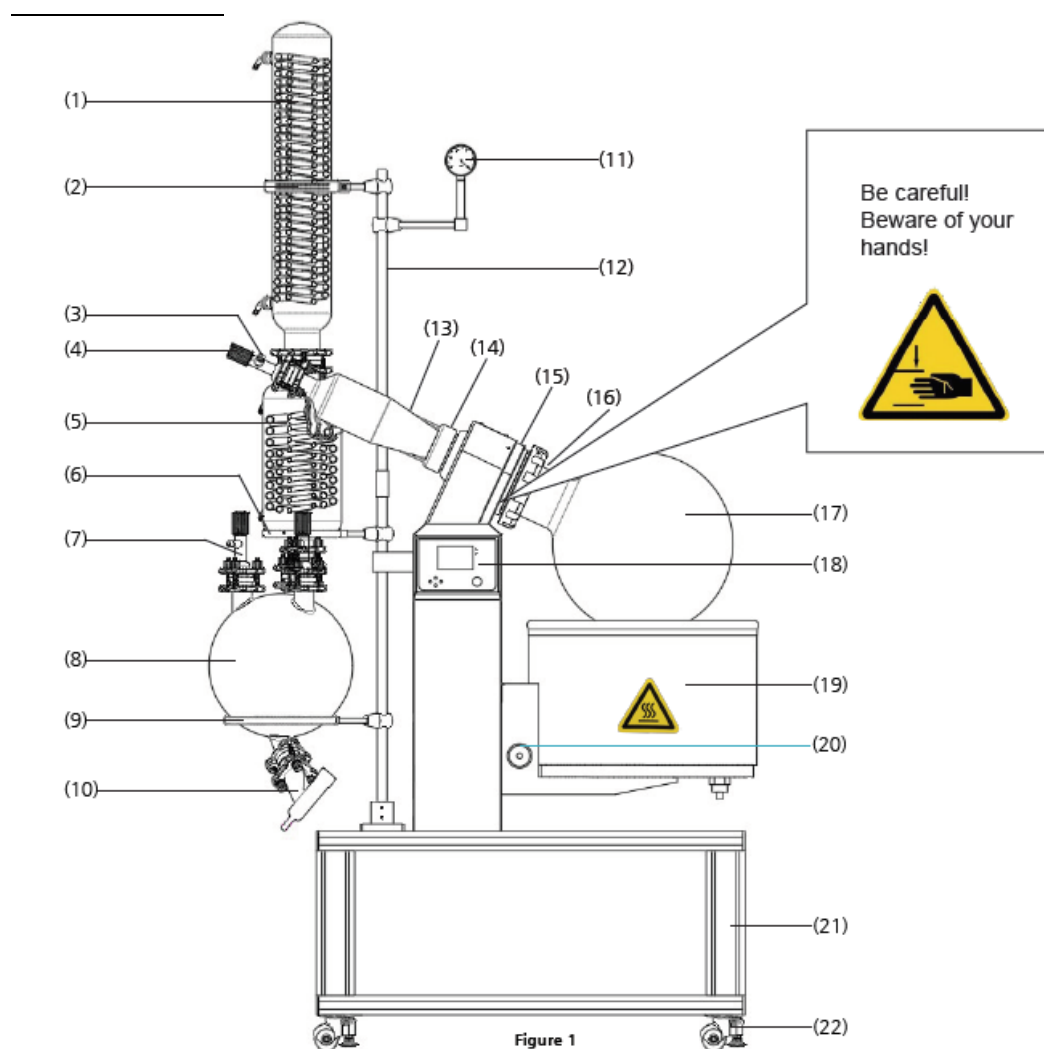

Figure 1

- (3) Continuous feed port
- (6) Condenser ring stand
- (9) Receiving flask ring stand
- (12) Upright rod
- (15) Reduction box
- (18) Instrument operation

- (2) Condenser ring clamp
- (5) Auxiliary condenser
- (8) Receiving flask
- (11) Vacuum gauge
- (14) Cap screw for Three-way flask
- (17) Evaporating flask

Goldleaf Scientific

(20) Temperature limit controller

Main condenser structure diagram :

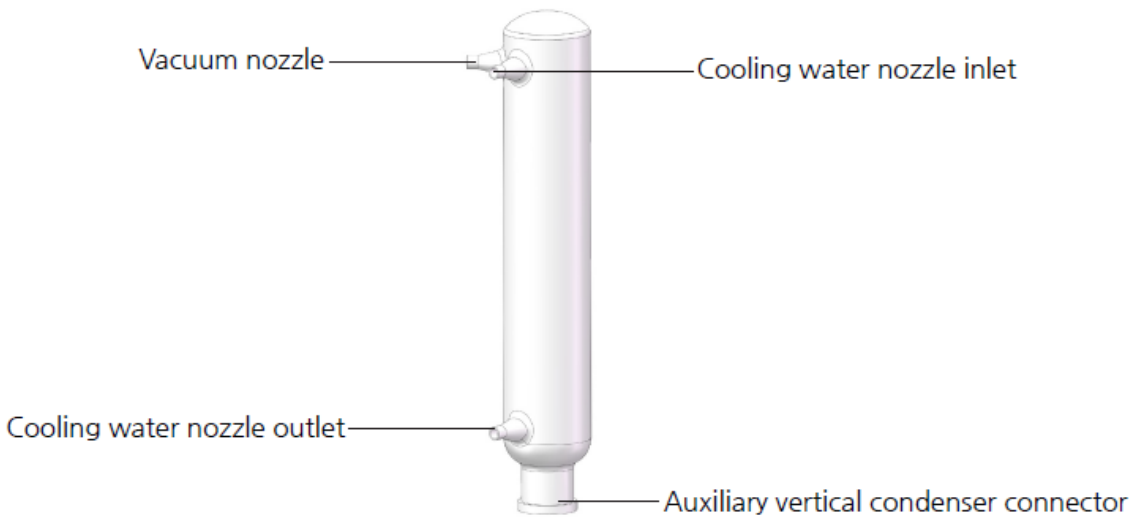

Figure 2

Three-way flask structure diagram :

<Single Condenser Type>

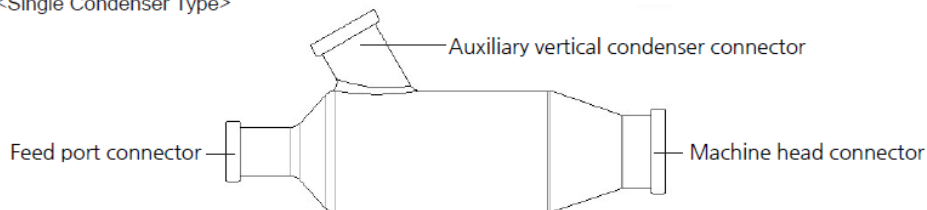

Figure 3

<Dual Condenser Type>

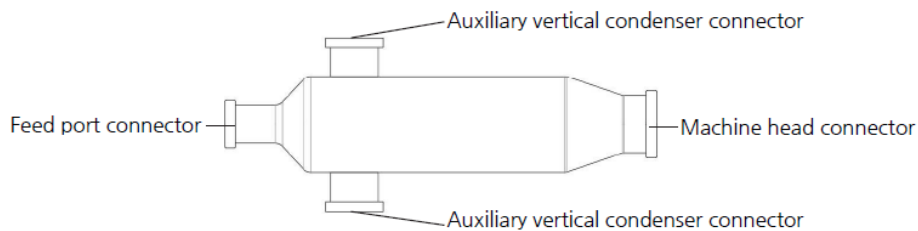

Figure 3-1

Auxiliary vertical condenser structure diagram :

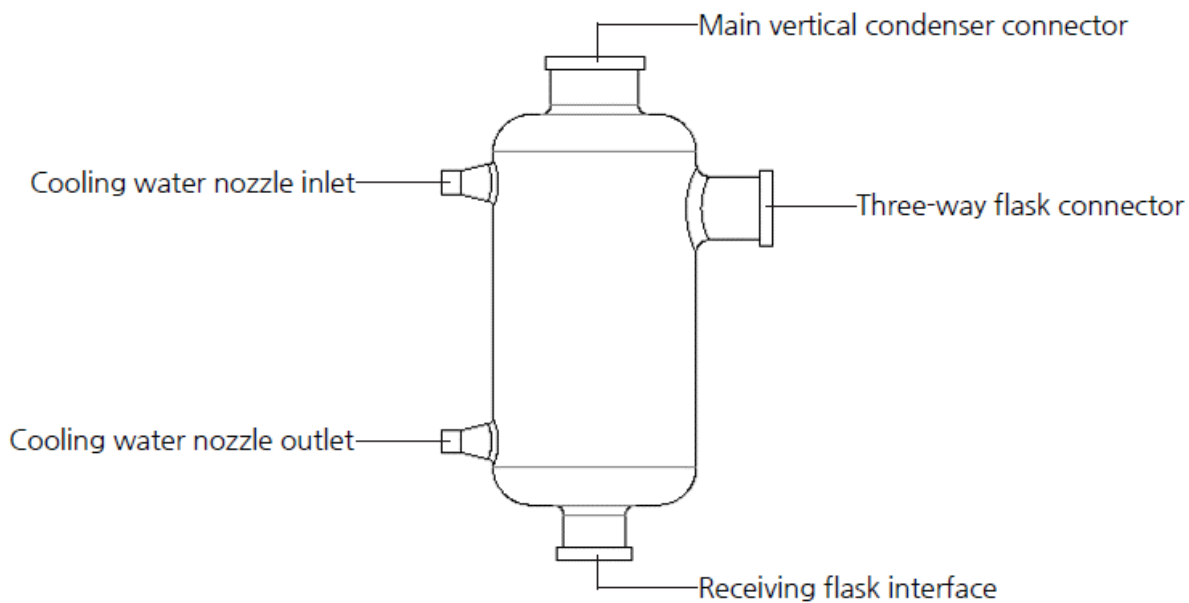

Figure 4

Receiving flask structure diagram :

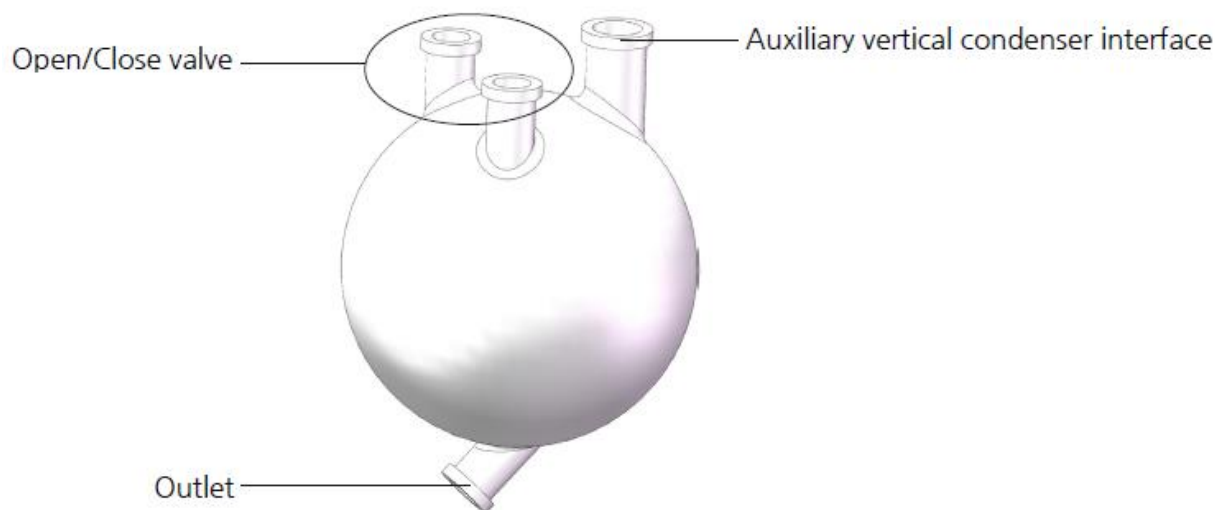
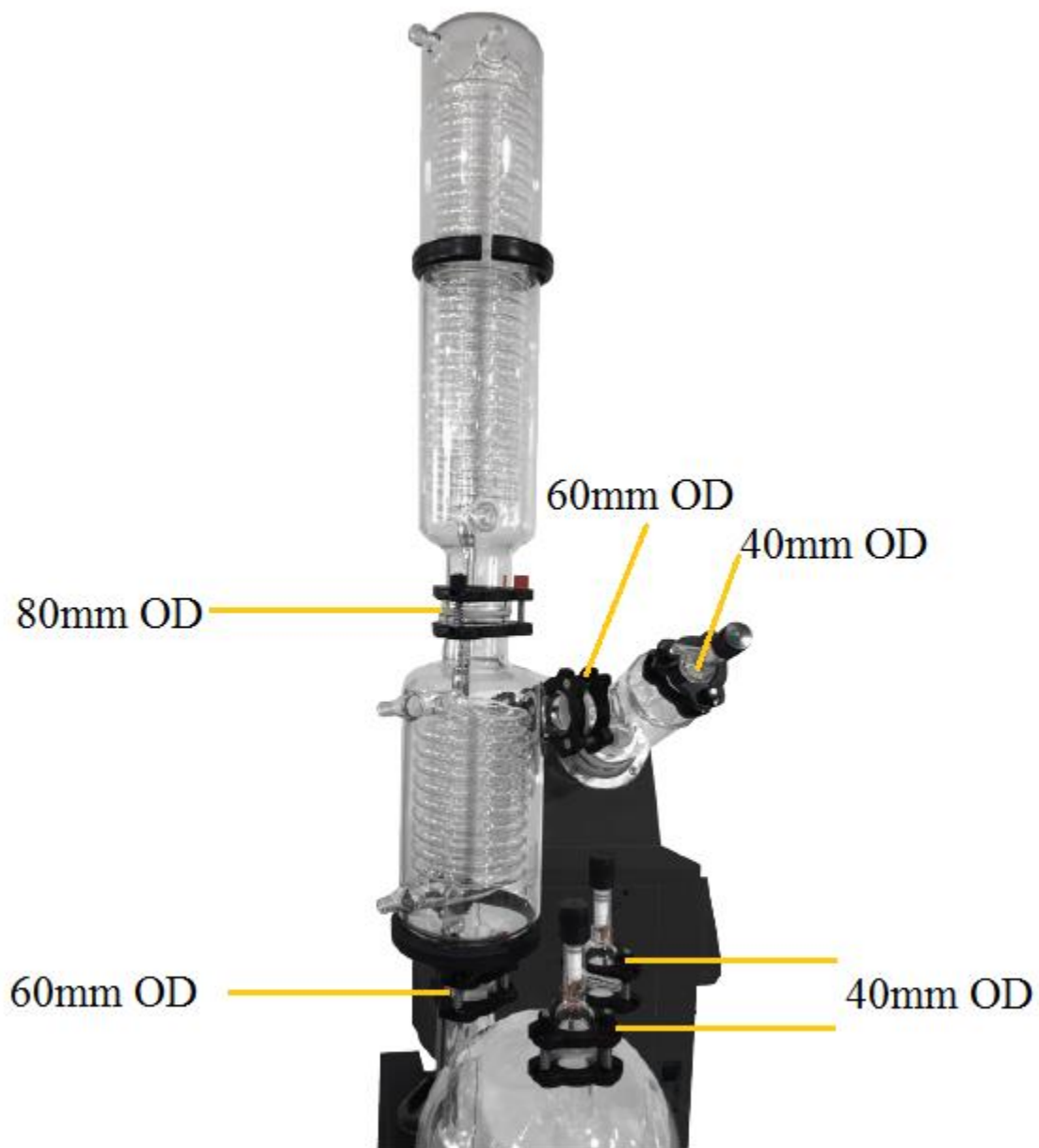

Figure 5

Goldleaf Scientific

Single Condenser Type



Goldleaf Scientific



Dual Condenser Type

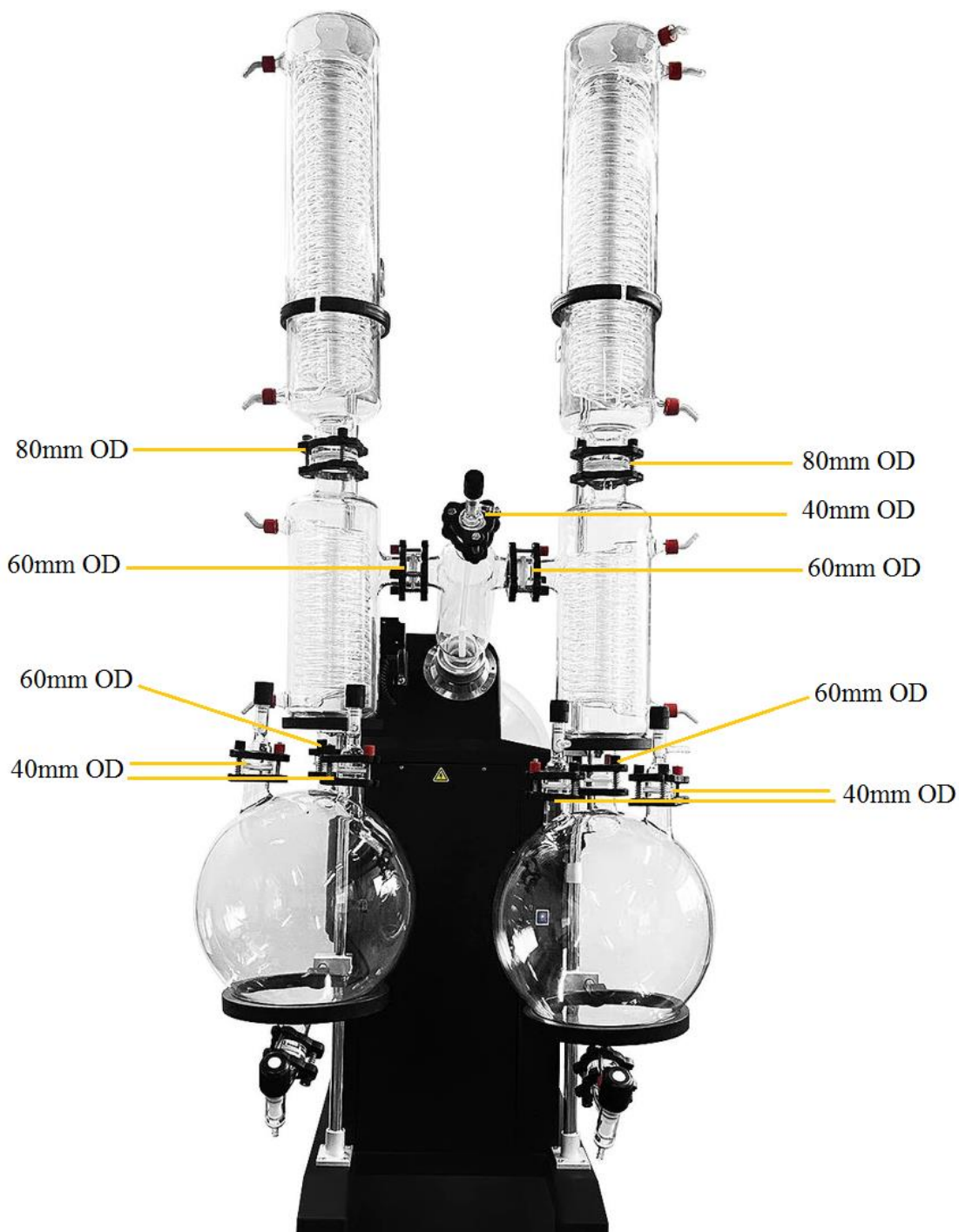

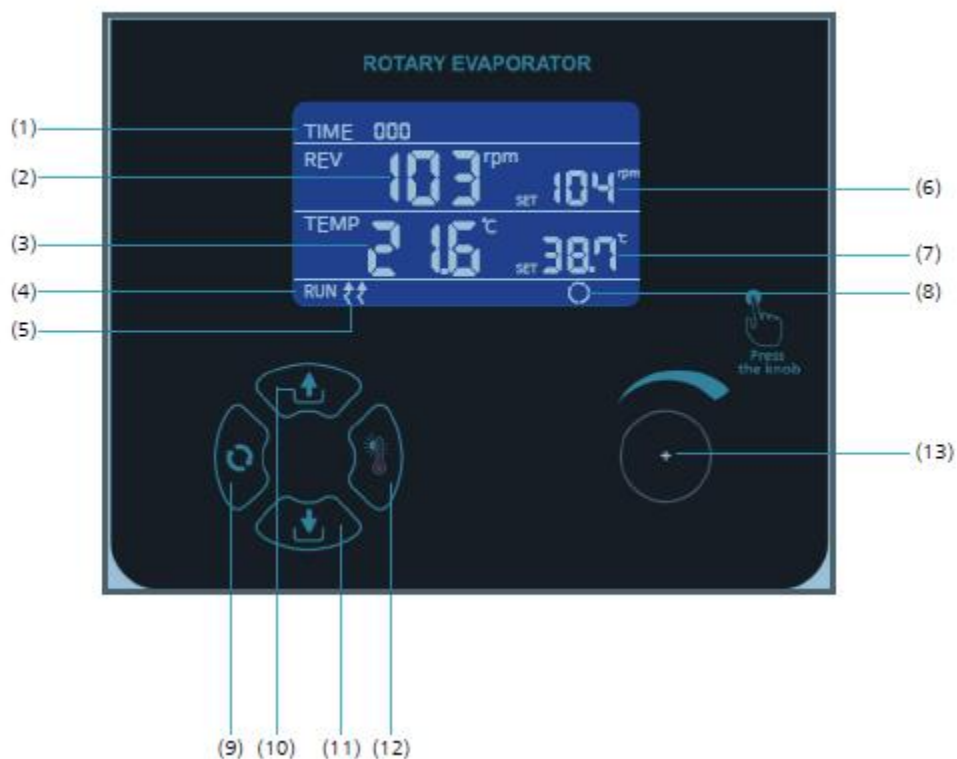

3.2 Rotary Evaporator Operating Instructions for operating panel



- (1) TIME: Time display window ; When the controller is in a timed state, "TIME" will display the running time (count down)
- (2) REV: Measured speed window ;
- (3) TEMP: Measured temperature window ;
- (4) RUN: Heating or rotating indicator, it will display when in heating or rotating status;
- (5) Heating indicator: It will display when there is a heating output ;
- (6) REV SET: Display setting speed, or display parameter value ;
- (7) TEMP SET: Display setting temperature, or display parameter value ;
- (8) Rotating indicator: Lights when rotating
- (9) "🔄" Key : Turn on or turn off rotation function ;



Goldleaf Scientific



- (10) "  "Key : Adjust the height of the host, press and hold this key can raise the water bath automatically;
- (11) "  "Key : Adjust the host height, press and hold this key can lower the height of water bath automatically
- (12) "  "Key : Turn on or turn off heating function ;
- (13) Knob key : Rotate left and right to set the time, temperature, and speed values.

3.3 Operation instructions

Turn on the instrument: Plug in the power and press the key on the left side of body to the "1" position.

When the rotary evaporator is on:

- (1) Time setting
Press pressing the knob for once, when "TIME" value flash, turn the knob left and right to adjust the desired time value, and press the knob key for once to confirm the time setting value;
- (2) Speed setting
Press pressing the knob for once, when "REV SET" value flash, turn the knob left and right to adjust the desired speed value, and press the knob key for once to confirm the speed setting value;
- (3) Temperature setting
Press pressing the knob for once, when "TEMP SET" value flash, turn the knob left and right to adjust the temperature speed value, and press the knob key for once to confirm the temperature setting value;
- (4) When the speed, time and temperature setting is completed, press "  "key or "  "key to start heating or rotating.

Note: The setting time is the running time, in minutes, it starts timing when you press "  "key, it will stop rotation after time is over, or press "  "key to stop the rotation in working status.

3.4. Operation of over-temperature protector

Over-temperature protector is an independent protective system. When temperature is out of control due to failure of the controller or the temperature in the working room reaches the set value for temperature limit on the over-temperature dial, the protector will cut off heating automatically and give an alarm sound. (as is shown in the right figure) when temperature in the working room is lower than the limit value, the protective system will be cancelled and the instrument resumes work. Such circulation will continue till fault is removed. Specific operation is done as follows:

1. The set value of temperature limit should be bigger than or equal to $(SV+AL) + (10-15) \text{ }^{\circ}\text{C}$
2. As is shown in Figure, Rotate the knob to make the desired temperature limit temperature value align with the scale indicator line For example:
SV=100 $^{\circ}\text{C}$, AL=10
Then 150 $^{\circ}\text{C}$ should be set up

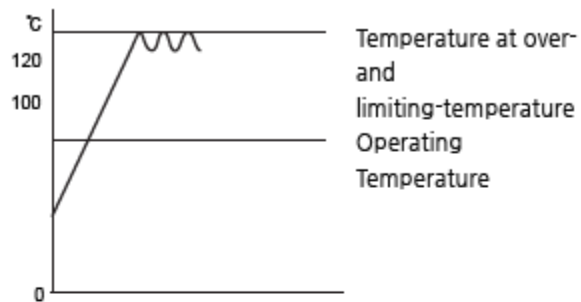

Figure 7

4. Installation

4.1 Stripping

1. Open the package, please check the parts according to the packing list. If there are any missing parts, please contact us.

1. Carefully clean the glass to maintain cleanliness before assembly.

1. Prepare all the tools you need for installation.

Note: The glassware set is fragile, please carefully unpack it.

4.2 Installation diagram of upright rod

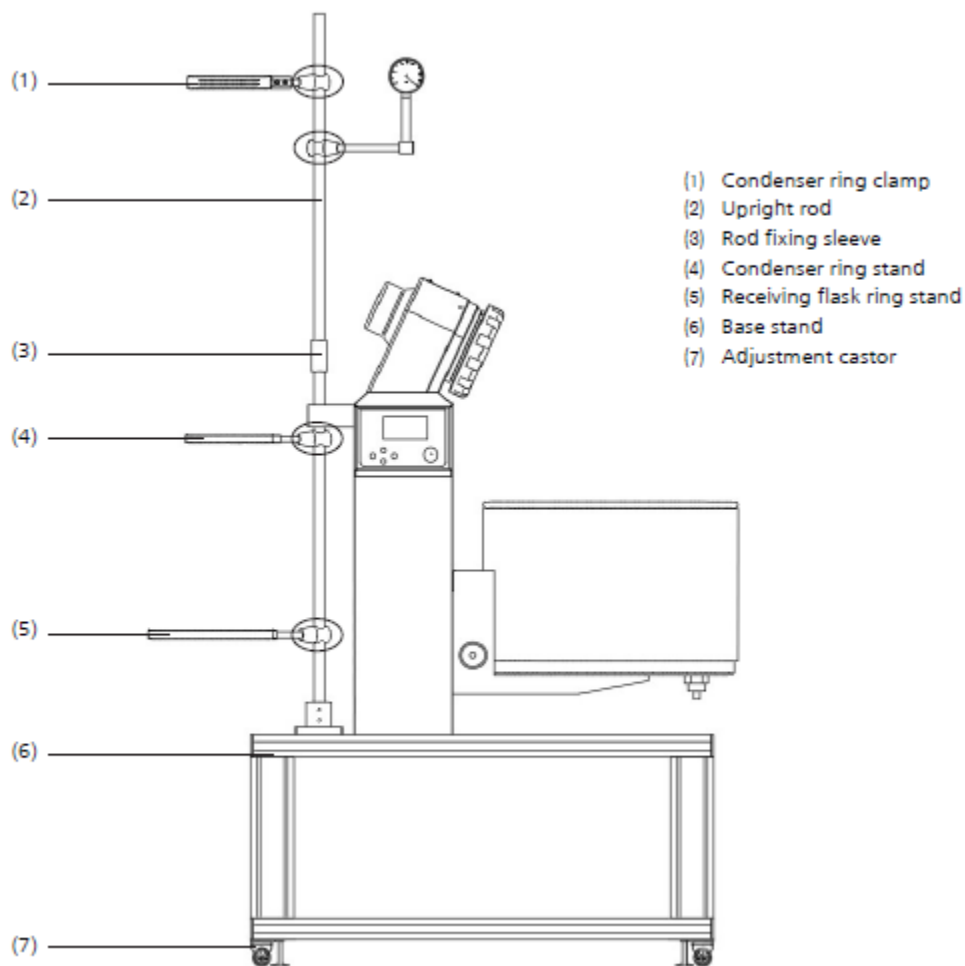

Figure 8

Installation process :

1. The upright rod (Fig.(2)) is inserted into the rod fixing sleeve (Fig.(3)), Adjust the position and tighten the two screws on the rod fixing sleeve;
2. If need to adjust the height of the condenser ring clamp(Fig.(1)) and condenser ring stand (Fig.(4)), receiving flask ring stand (Fig.(5)), just loosen the two screws on the mount, move up and down to the desired height and tighten the screws.

Note: (Figure (4)(5)) When the condenser ring stand and receiving flask ring stand are installed, the side with the anti-vibration ring (silica gel) is facing up.

4.3 Installation diagram of three-way flask, rotating shaft, evaporating flask

Install the main and secondary seals on the right side of the rotating shaft (Fig.(8)(9)), place the screw for evaporating flask (Fig.(11)) on the base of the evaporating flask neck, evaporating flask lock gasket (Fig.(10)) placed on the neck of the evaporating flask, tighten the screw for evaporating flask properly.

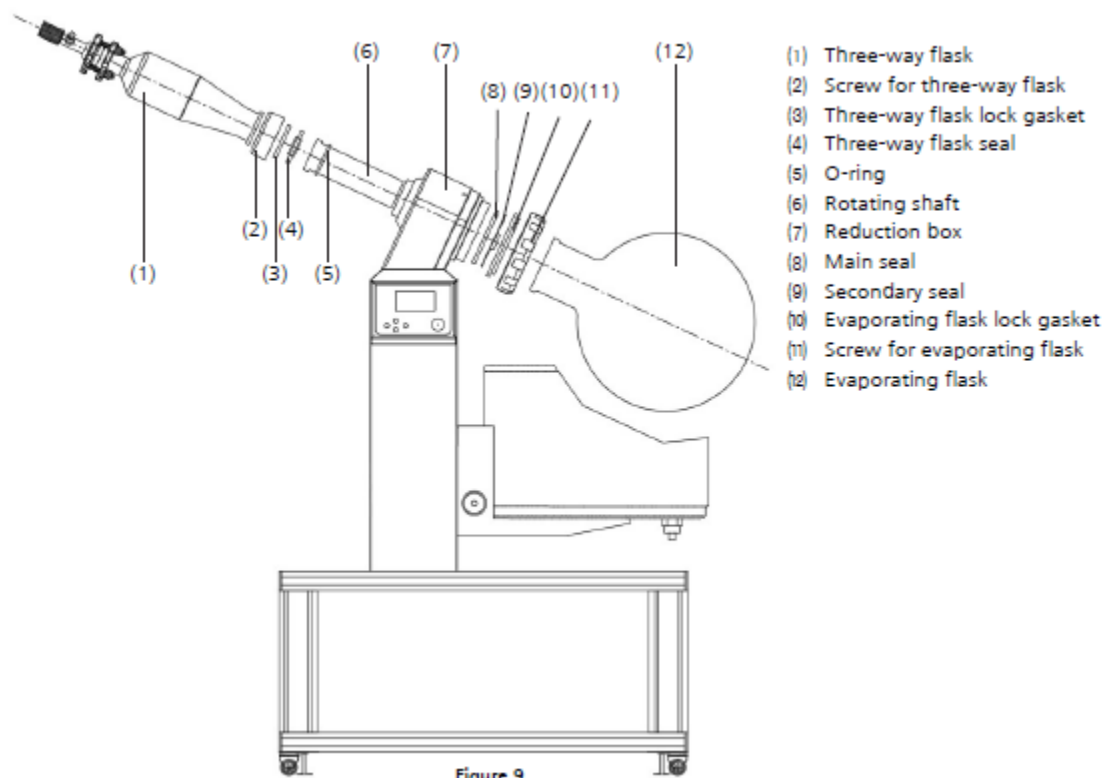

Goldleaf Scientific

Installation process :

1. Put the O-ring (Fig.(5)) on the rotating shaft (Fig.(6)), then insert the rotating shaft into the reduction box from the left side and requires that the O-ring on the rotating shaft close to the rotating mechanism housing.
2. Put the screw for three-way flask (Fig.(2)) on the lower port of the three-way flask (Fig.(1)), then put the three-way flask gasket (Fig.(3)) on the lower neck of the three-way flask, insert the three-way flask seal (Fig.(4)) into the diameter of the three-way flask, finally insert the three-way flask into the upper end of the rotating shaft, adjust the position of the three-way flask, tighten the screw for three-way flask properly.
3. Install the main and secondary seals on the right side of the rotating shaft (Fig.(8)(9)), place the screw for evaporating flask (Fig.(11)) on the base of the evaporating flask neck, evaporating flask lock gasket (Fig.(10)) placed on the neck of the evaporating flask, tighten the screw for evaporating flask properly.

Positioning the evaporating flask: Insert the inner hexagon wrench into the hole of the rotating base (inclined left), adjust the position of the rotating shaft, align the hole in the shaft with the hole in the base, use the inner hexagon wrench to keep the position of the rotating shaft unchanged, install the evaporating flask with screw and gasket on the right end of the glass rotating shaft, tighten the screw for evaporating flask. Start the rotating shaft and observe its operation, and the rotating shaft is required to run smoothly.

Note: During the installation process, the glassware set should be handled gently, and the position of the flask mouth and the flask mouth should be appropriate to avoid damage the glass device!

4.4 Installation diagram of main condenser, receiving flask and check valve.

Check Valve

Upper (Auxiliary condenser mouth)

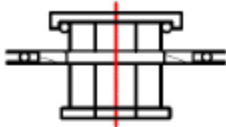

Under ->

(Receiving flask mouth)

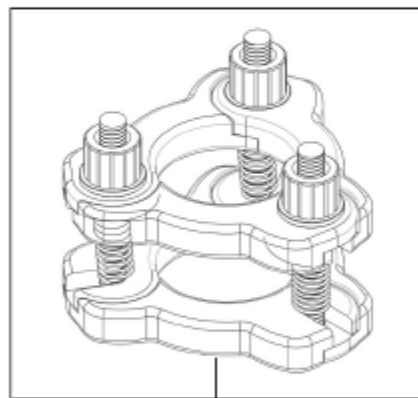

Fixed flange

Seal

<Single Condenser Type>

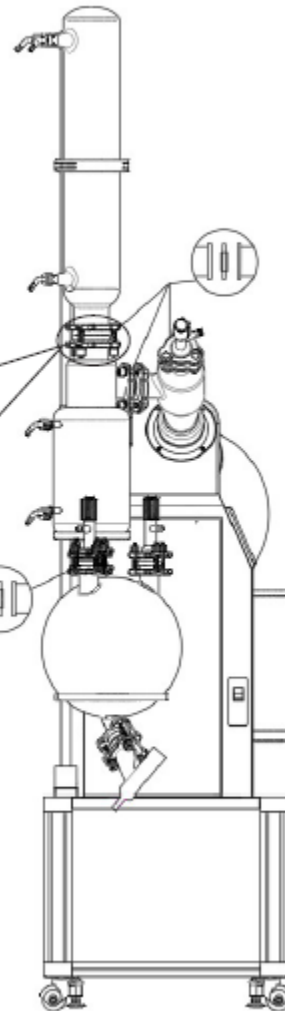
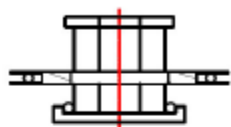

Figure 10

<Dual Condenser Type>

Check Valve

Upper (second condenser bottle mouth)



Under ->

(Receiving flask mouth)

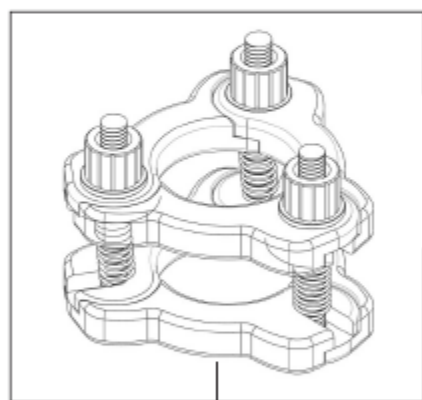

Fixed flange

Seal

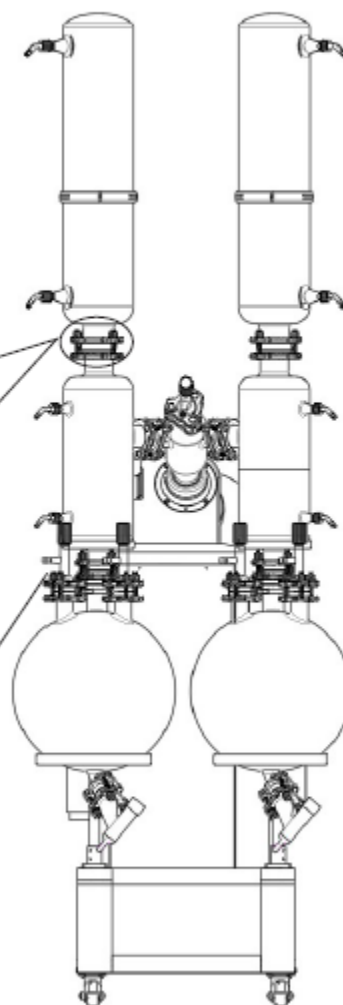

Figure 10-1

Installation process :

1. Fix condenser ring stand on the rod and place the auxiliary condenser on the ring stand, adjust the required height, keep the auxiliary condenser side interface and the three-way flask interface at the same level, tighten the screws of condenser ring stand and the clamp mount. Then install the fixing flange on the root of the auxiliary condenser interface, install the flange retaining ring on the neck of the auxiliary condenser, and tighten the screws on the fixing flange.
1. The installation method of main condenser is the same as auxiliary condenser, fix condenser ring clamp on the rod and place the main condenser on the ring clamp, put the fixing flange at the lower end of the main

condenser, while placing the flange retaining ring, align the lower end of the main condenser with the upper end of the auxiliary condenser, and tighten the screws on the fixing flange.

1. Loosen the two screws on the receiving flask ring stand, move up and down to the desired height and tighten the screws, fixing the receiving flask ring stand and the mount; place the receiving flask on the holder, install the fixing flange on the root of the receiving flask interface, and place the flange retaining ring at the same time, use the same method to connect and secure the upper end of the receiving flask to the lower end of the auxiliary condenser.

Note: During the installation process, the glassware set should be handled gently, and the position of the flask mouth and the flask mouth should be appropriate to avoid damage the glass device!

4.5 Other parts installation

1. Drain valve installation: Install the drain valve directly in the diameter of the receiving flask;
2. Main and auxiliary seal ring installation:

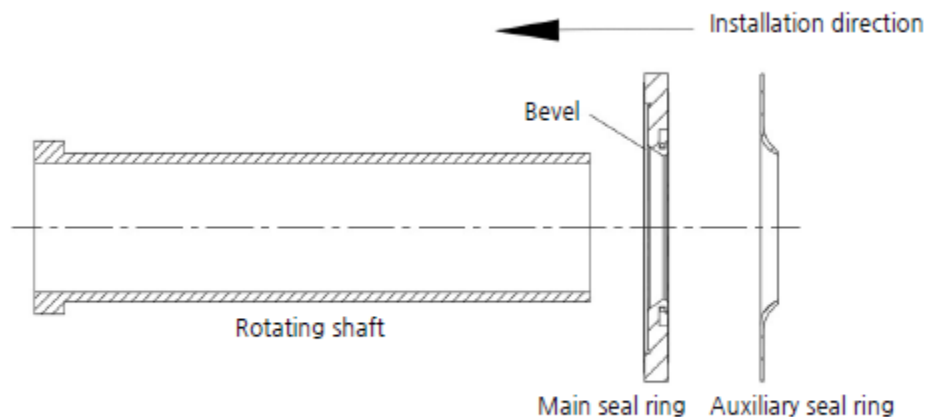

Figure 11

- Installation of vacuum gauge: Install the vacuum gauge holder and vacuum gauge on the vacuum gauge clamp, tighten the screws and adjust the bracket to the appropriate height. (Optional part)
- 3.

5. Specifications

| Model | 20L | 20L Double Condenser | 50L | 50L Double Condenser |
|-------------------------------|---|---------------------------------|------------------------------|---------------------------------|
| Operating Ambient Temperature | 5-35℃ / 41-95℉ | | | |
| Glass Material | GG-17 High Borosilicate | | | |
| Rotation Motor | DC brushless, 250w | | | |
| Lifting Motor | DC brushless, 100w | | | |
| Power (V/Hz) | 220V 60Hz Single Phase | | | |
| Speed Setting | Knob setting +LCD controller | | | |
| Vacuum Seal | PTFE + Teflon coating | | | |
| Temperature Control | PID Controller | | | |
| Cooling Area (㎡) | 0.948+0.458 | 1.896+0.916 | 1.15+0.607 | 2.3+1.214 |
| Rotation Speed | 20-130 rpm | | 20-110 rpm | |
| Bath Temp. Control Range | RT + 5 - 99.9 ℃ | | RT + 5 - 85 ℃ | |
| Maximum Vacuum Pressure | < 6 torrs | | | |
| Evaporating Flask Capacity | 20L / 5.28 gallon | | 50L / 13.20 gallon | |
| Receiving Flask Capacity | 10L / 2.64 gallon | 10L x 2pcs / 5.28 gallon | 20L / 5.28 gallon | 20L x 2pcs / 10.56 gallon |
| Condenser Style | Main + Auxiliary Vertical Double Helix | | | |
| Water Bath Material | Stainless steel corrosion resistant coating | | | |
| Water Bath Size | ∅445x250mm/∅17.5"x9.8" | | ∅540 x 340mm/∅21.3"x13.4" | |
| Lift Mode | Auto lift | | | |
| Lifting Distance | 210mm/82.7" | | 250mm/98.4" | |
| Heating Power | 4000W | | | |
| Packing Dimension | 42.5"x27.2"x55.9" (LxWxH) | 56.69"x27.17"x43.31" (LxWxH) | 49.2"x27.6"x63.8" (LxWxH) | 51.58"x27.56"x71.26" (LxWxH) |
| Gross Weight | 170kg/375lbs | 192kg / 423lbs | 190kg/419lbs | 212kg / 467lbs |
| Vacuum Connection | M18 | | | |
| Condenser Connection | M18 | | | |
| Safety | 1. Over current protection | | 2. Over temp. protection | |
| | 3. Power interruption alarm | | 4. Anti-dry protection | |

Note: This product is available with a recirculating chiller and a corrosion-resistant diaphragm pump!

6. Operating instructions

6.1 Preparation before operation





Ensure that the product use environment meet the following conditions of use:

1. Use it in the room (not for outdoor use);
2. Ambient temperature: 5~35°C;
3. Power supply : AC 220V 50/60HZ;
4. Atmospheric pressure: (86~106)KPa;
5. Altitude no higher than 4000 meters;
6. Use of the environment: low humidity, good ventilation, clean air, no direct sunlight;
7. No intense shock source and strong electromagnetic field around;
8. It should be placed on a steady, horizontal and solid bench or ground without direct sunlight. No heavy dust or corrosive gas in the room;
9. There should be no less than 50CM gap around the product (front, back, left, and right), and the height should be no less than 100cm.

6.2 Instructions for use

Place the instrument on a hard, firm surface before handling, keep it horizontal; a certain gap should be left around the instrument. The glassware set may exceed the height of the instrument; the product must be used under certain conditions of use; ensure that the instrument does not move due to vibration when it is turned on.

6.3 Setting order of each function

1. After the controller is powered on, it passes the self-test. The TIME window displays the setting time; the REV window of the LCD displays the measured speed, TEMP displays the measured temperature (no displayed when there is no temperature), the REV SET area displays the setting speed, and the TEMP SET area displays the setting temperature.; this state is a standard state;
2. Speed temperature setting: Click the knob to set the time, speed, and temperature. Press the knob and hold on it will return to the initial interface.
3. Run, stop: click "  "key, switch between allowing heating and stopping heating, click "  " key, switch between allowing motor running and stop.
4. Self-tuning function: If the temperature control effect is not ideal, please start auto-tuning. In standard state, press temperature running key more than 3 seconds, The (4) area flashes and the controller enters the self-tuning, the temperature fluctuates through three rounds, after auto-tuning will get a new set of PID parameters, the controller is controlled by the new PID parameters. In the auto-tuning, press the temperature running and hold on to exit the auto-tuning.
5. Lift function: When in the standard state, press the "  "key to rise; press the "  "key to decrease;
6. Turn the knob to the right to increase the digit; the left turn to decrease the digit.

7. Troubleshooting

| Symptoms | Reasons for Failure | Troubleshooting Method |
|--|--|--|
| Turn on the power switch light does not light | The power plug is unplugged or plugged not well. (When connected to the water bath, please also confirm the water bath power connection) | Set the power switch to the OFF position ("0") then inserting the power plug into the socket. |
| | Plug the power cord from the fuse with the power base off or not inserted tight. | Set the power switch to the OFF position ("0"), and then plug the power cord into the power cord holder. |
| | Power is not applied. | Please open the switchboard protection switch. |
| | Power switch has failed. | Please stop using it immediately and contact the dealer or the nearest service center of this product. |
| | Circuit board failure. | |
| Fuse is blown due to overload. (Short circuit) | | |
| Power switch indicator light, but does not rotate. | Rusty bearings | Please stop using it immediately and contact the dealer or the nearest service center of this product. |
| | The motor has failed. | |
| | Circuit board failure. | |
| Evaporating flask oscillation | Internal gear wear. | Re-install Please lock it. |
| | The installation for evaporating flask is not good. The screw for evaporating flask is unlocked | |
| Abnormal sounding | Seal wear. | Please replace the seal. |
| | Internal gear wear. | Please stop using it immediately and contact the dealer or the nearest service center of this product. |
| | Drive lack of oil. | |
| | The motor has failed | |
| Noise from the seal ring | Seal with the rotating shaft with poor contact. | Please apply a thin layer of vacuum grease or water on the seal ring. |
| Pressure leak vacuum is not good | Rotating connection shaft wear. | Please replace the rotary connection shaft. |
| | Seal wear | Please replace the seal. |
| | Bad seal installation. (Opposite direction) | Please refer to the seal installation method, re-install. |
| | Decompression with gas nozzle gasket aging. | Please replace the air nozzle seal gasket. |
| | Vacuum hose aging | Please replace the vacuum hose. |

8. Maintenance

1. Please do not disassemble the device, the device has a voltage or high temperature inside the part, such as disassembly dismantling device, will cause personal injury.
 2. Please use the correct method and supplies appliances for cleaning and maintenance of this product. Do not spill water directly onto the product, or use abrasive powders, thinners, petroleum, kerosene, acid substances and the like, otherwise accidents such as electric shock may occur.
 3. Please turn off the power switch before maintenance, unplug the power plug from the socket.
 4. Cleaning, please wring the water wipe soft cloth, the dirt that not easy to remove, please use a neutral detergent, use a rag wipe clean after using detergent.
 5. Carefully check before using equipment, if the glass bottles are damaged, the interface is consistent, pay attention to gently.
 6. Wipe the interface with a soft cloth (disposable paper towels), and then apply a small amount of vacuum grease. After the use of vacuum grease must be covered well to prevent lime sand into.
 7. The interface could not be screwed too tight, to loosen the active regularly, to avoid long-term tight connector killed.
 8. First turn on the power switch, and then let the machine run from slow to fast, stop when the machine is in a stopped state, and then off the switch.
 9. Fasteners could not be tightened everywhere, easy to damage the glass.
 10. After each use must be wiped with a soft cloth to stay in the surface of the machine a variety of oil stains, solvent left, keep clean.
 11. Loosen the fasteners around the machine once downtime, long-term still in the working state will make the ring deformation.
 12. Regular cleaning of the glass axis of rotation, the method is: Remove the ring, check the shaft is dirt, wipe clean with a soft cloth, and then apply a small amount of vacuum grease, re-install, keep the shaft and the seal smooth.
 13. Electrical parts must not be water, strictly prohibited damp.
-

Goldleaf Scientific

Packing List

Product name : Rotary Evaporator

| | Category | Name | Unit | Qty. | Comments |
|---|-------------|--------------|------|------|--|
| 1 | Components | Host | Set | 1 | |
| 2 | Components | Pole | Pc | 1 | |
| 3 | Components | Glassware | Set | 1 | Evaporating flask, Receiving flask, Main and auxiliary condenser, Rotating shaft, Feeding valve, fixing flange, seal ring |
| 4 | Components | Ring stand | Set | 1 | |
| 5 | Components | Bracket | Set | 1 | |
| 6 | Spare parts | Nozzle SET | Pc | 5 | |
| 7 | Document | Use manual | Copy | 1 | |
| 8 | Document | Packing list | Copy | 1 | |

Goldleaf *Scientific*

Notes

Goldleaf *Scientific*

Notes

Goldleaf Scientific

Thank you for choosing Goldleaf scientific!

We aim to make the absolute best laboratory and scientific equipment available and we cannot do so without your help. Any feedback is helpful so if there's any area you think we could improve please let us know.

*We have glassblowing in house and can repair broken glass parts quickly.

**Goldleaf Scientific LLC
1498 Zephyr ave. Hayward, CA 94544
www.Goldleaflabs.com**