

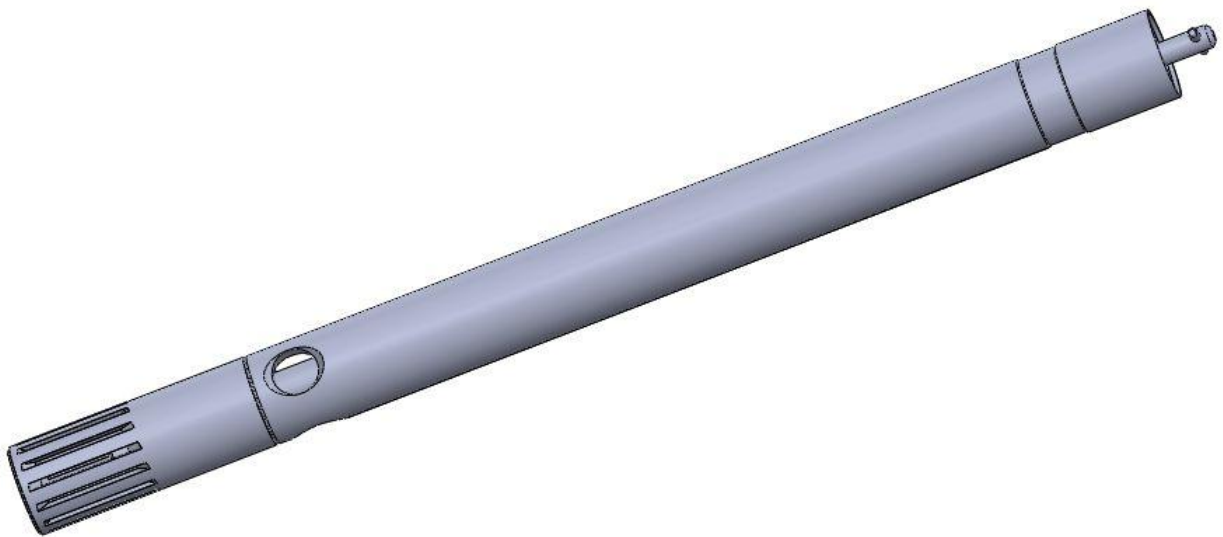

## **Instruction Manual**

### **Homogeniser Tools**

**T 6, T 10, T 17, T/G 20, T/G 30, T/G 40**



# Content

1	User Instructions .....	4
1.1	Important Instructions for your safety .....	4
1.2	Danger symbols in this operating manual.....	4
1.2.1	Danger symbols:.....	4
1.2.2	Danger levels.....	4
2	General safety warnings and instructions .....	5
3	Unpacking the Instrument .....	7
3.1	Scope of delivery .....	7
3.2	Homogenising Tools and Accessories (to be ordered separately):.....	7
4	General Information .....	8
4.1	Combinations of Generators (using the example of shaft T 20) .....	9
4.2	Exchanging the Generator:.....	10
4.2.1	Disassembling Shaft T 6 .....	10
4.2.2	Reassembling Shaft T 6 .....	11
4.2.3	Disassembling Shaft T 10/T 17 .....	12
4.2.4	Reassembling Shaft T 10/T 17 .....	12
4.2.5	Disassembling Shaft T 20/T 30/T 40 .....	13
4.2.6	Reassembling Shaft T 20/T 30/T 40 .....	14
4.2.7	Disassembling Shaft G 20/G 30.....	15
4.2.8	Reassembly of Shaft G 20/G 30 .....	16
4.2.9	Disassembling Shaft G 40.....	17
5	Maintenance and Cleaning .....	18
5.1	Cleaning the homogenising tool.....	18
5.2	Maintenance homogenizing tools.....	18
6	Transport and Storage .....	18
7	Disposal .....	19
8	Warranty and Liability.....	19
9	Technical Data.....	20
9.1	Technical Data .....	20
9.2	Technical Data Rotors and Stators .....	20
10	Repairs.....	21
10.1	Repair Return Form .....	22



# 1 User Instructions

## 1.1 Important Instructions for your safety



- Every user must read and understand this manual completely before use. Failure to do so can result in serious injury or death.
- Comply with all safety and accident-prevention regulations applicable to laboratory work.
- Follow general instructions for hazard prevention and general safety instructions, e.g. wear protection clothing, eye protection and gloves.
- This operating manual is part of the product. Thus, it must always be easily accessible.
- This instruction sheet does not purport to address all of the safety problems which might result from the use of this device, chemicals, reagents, apparatus or equipment employed in any specific test or protocols. It is the responsibility of the user to consult their authorized safety advisors and establish appropriate health and safety practices and then determine the application of regulatory limitations prior to use.
- Enclose this operating manual when transferring the device to another place.
- If this manual is lost, please request another one. Please contact your dealer or





### Goldleaf Scientific

3300 Harrison st suite 2  
Riverside CA 92503  
510-487-1390  
suuport@goldleafflabs.com

## 1.2 Danger symbols in this operating manual

The safety instructions in this manual appear with the following danger symbols and danger levels:



### 1.2.1 Danger symbols:





 <b>Hazard point</b>	 <b>Crushing</b>
 <b>Bio hazard</b>	 <b>Chemical hazard</b>

### 1.2.2 Danger levels

<b>▲ DANGER</b>	Will lead to severe injuries or death
<b>▲ WARNING</b>	May lead to severe injuries or death
<b>▲ CAUTION</b>	May lead to light to moderate injuries
<b>NOTICE</b>	May lead to material damage

## 2 General safety warnings and instructions

	<p><b>▲WARNING</b> <b>Damage to health due to noise</b></p> <p>If noise level exceeds 85 dB (A) at the work station operator must use ear plug and/or ear mufflers.</p>
	<p><b>▲WARNING</b> <b>Damage to health due to corrosive or aggressive chemicals</b></p> <ul style="list-style-type: none"> <li>● Observe all markings on the reagent bottles.</li> <li>● Always check the instrument for leaks and air bubbles. Special attention should be directed to determine that all push-ons, threaded connections and suction tubes are firmly in place before beginning operation. <ul style="list-style-type: none"> <li>Leaking solutions may endanger persons and materials</li> </ul> </li> <li>● Use proper connecting vessels, protective clothing and gloves.</li> <li>● Avoid splashes</li> <li>● When dispensing, maintain a physical distance between the instrument and the body.</li> <li>● Dangerous and fuming chemicals must be dispensed in a fume hood.</li> <li>● Only employ the instrument for the purpose intended by the manufacturer, and particularly within the resistance limits of the instrument. If in doubt, contact your supplier, or the manufacturer's factory representative at the phone number shown at the front page of this operating instruction.</li> <li>● Always use the instrument in such a manner that neither the operator, nor any other person is endangered.</li> </ul>
	<p><b>▲WARNING</b> <b>Damages to health due to infectious liquids and pathogenic germs.</b></p> <ul style="list-style-type: none"> <li>● When handling infectious liquids and pathogenic germs, observe the national regulations, the biological security level of your laboratory, the material safety data sheets and the manufacturer's application notes.</li> <li>● Wear personal protective equipment</li> <li>● For comprehensive regulations about handling germs or biological material of the risk group II or higher, please refer to the "Laboratory Biosafety Manual" in its respectively current valid version from the World Health Organisation</li> </ul>

	<p><b>⚠WARNING</b> <b>Damage to health due to contaminated device and accessories</b></p> <p>In the following cases, sample material can be released:</p> <ul style="list-style-type: none"> <li>- improperly sealed tubes</li> <li>- unstable tubes</li> <li>- high vapour pressure of the content so that the seal of the tubes can spring open</li> <li>- damaged sealings</li> <li>- smashed glass tubes</li> </ul> <ul style="list-style-type: none"> <li>● Only mix in closed tubes</li> <li>● Observe the nationally prescribed safety environment when working with hazardous, toxic and pathogenic samples. Pay particular attention to personal protective equipment (gloves, clothing, goggles, etc.), extraction, and the safety class of the lab.</li> <li>● Decontaminate the device and the accessories before storage and shipping.</li> </ul>
	<p><b>⚠CAUTION</b> <b>Poor safety due to inadequate fixing of the unit</b></p> <ul style="list-style-type: none"> <li>● Ensure that the unit is firmly attached to a solid stand.</li> </ul>
	<p><b>⚠CAUTION</b> <b>Poor safety due to incorrect accessories and spare parts.</b></p> <p>The use of accessories and spare parts other than recommended by Goldleaf Scientific may impair the safety, function and precision of the device.</p> <p>Goldleaf Scientific cannot be held liable or accept any liability for damage resulting from the use of incorrect or non-recommended accessories and spare parts, or from the improper use of such equipment.</p> <ul style="list-style-type: none"> <li>● Only use accessories and spare parts recommended by Goldleaf Scientific</li> </ul>
	<p><b>⚠CAUTION</b> <b>Crush hazard due to moving parts</b></p> <ul style="list-style-type: none"> <li>● Do not replace any consumables as long as the device is running.</li> <li>● Do not open the coverage as long as the device is running</li> </ul>

### 3 Unpacking the Instrument

Unpack the instrument carefully and check to see that it is not damaged. It is important that any damage incurred in transport to be recognized at the time of unpacking. Notify your carrier or forwarding agent immediately in case of such damage.

#### 3.1 Scope of delivery

The dispersion tools you have ordered are always supplied fully assembled.

Please check that the package contains the following:

1 fully assembled Shaft

1 Instruction Manual

#### 3.2 Homogenising Tools and Accessories (to be ordered separately):

Tools	Description	Part No.
<b>T 6</b>	Shaft, 6 mm diameter, 55 mm long,	60420-*
<b>T 6</b>	Shaft, 6 mm diameter, 120 mm long,	60410-*
<b>T 10</b>	Shaft, 10 mm diameter	60421-*
<b>T 17</b>	Shaft, 10 mm diameter, for 17 mm generator	60426-*
<b>T 20</b>	Shaft, 20 mm diameter, for 20 mm generator	60422-*
<b>G 20</b>	Shaft, 20 mm diameter, for 20 mm generator	60423-*
<b>T 30</b>	Shaft, 20 mm diameter, for 30 mm generator	60424-*
<b>G 30</b>	Shaft, 20 mm diameter, for 30 mm generator	60425-*
<b>T 40</b>	Shaft, 20 mm diameter, for 40 mm generator	60414-*
<b>G 40</b>	Shaft, 20 mm diameter, for 40 mm generator	60415-*

Extensions of the Part Numbers ...-*	
<b>-00</b>	Shaft without generator
<b>-F.</b>	Shaft with generator type F
<b>-M.</b>	Shaft with knife generator
<b>-N.</b>	Shaft with generator type N
<b>-V.</b>	Shaft with generator type V

<b>Universal wrench</b>	Universal rotor wrench for Shafts T 6 – T 30, G20, G 30	60470-00
<b>Socket wrench</b>	for all shafts	60471-00
<b>Rotor wrench</b>	for shaft T 10	60472-00
<b>Rotor wrench</b>	for shaft T 17: use Universal wrench	60470-00
<b>Rotor wrench</b>	for shaft T 20/G 20	60473-00
<b>Rotor wrench</b>	for shaft T 30/G 30	60476-00
<b>Rotor wrench</b>	for shaft T 40/G 40	60477-00



#### CAUTION

The Generators (A) have sharp edges. Handle with care.

Risk of injuries!

## 4 General Information

The homogenizing tools come always assembled. The connecting adapter (drive pin (4)) is located on the top of the shaft and is used to attach the shaft to the drive motor or to the socket wrench (B) during assembling or disassembling.

On the other end of the shaft there are stator and rotor. Socket wrench and rotor wrench (C) are used for assembly resp. disassembly.

A dispersion tool consists of a shaft and a generator (rotor and stator).

### Shaft:

The shaft mainly consists of the shaft tube, the drive shaft rotating shaft inside the shaft tube, the bearing and the shaft sealing.

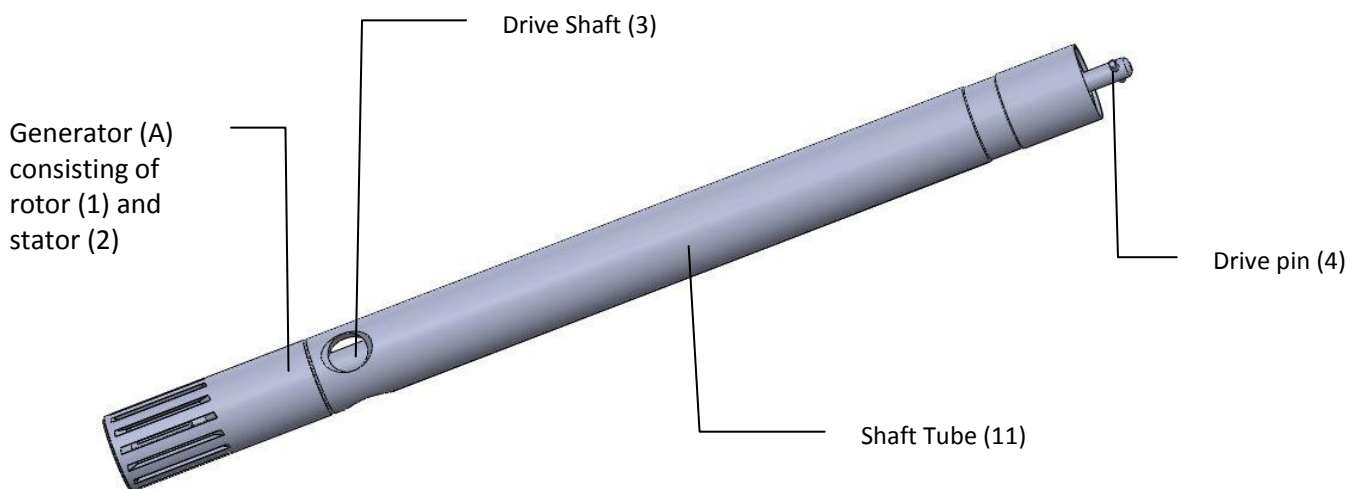

The shaft cannot be used alone. Only combinations of shaft and generator (A) can be used for working with a medium.

### Generator:

The generator (A) consists of a rotor (1) and a stator (2). These parts can be unscrewed from the shaft.

**T = Shaft with ETFE bearing.** This shaft type is used for standard application. (For liquid media like water, oil, etc.) The bearing must be cooled by the media, which penetrates into the bearing. A dry run is not permitted.

**G = Shaft with slide seal ring.** This shaft type is excellent for applications with aggressive respectively abrasive media and when pressure is applied. Also suitable for use with solids. The bearing is sealed and suitable for dry running

### NOTICE

Never run a homogenising tool of **type T dry** as the bearings and gaskets will be damaged if the generator is not cooled by the medium. The distance between the homogenising tool and the vessel bottom should not be less than 10mm. The filling of the medium may not be less than about 55 mm. To avoid a vortex it is necessary to insert the dispersing shaft out of the centre of the vessel. If these conditions are met the unit is ready for operation.



#### 4.1 Combinations of Generators (using the example of shaft T 20)

**NOTICE** Rotors and stators form matching pairs. They can be combined to form F-, N-, V-generators. Exceptions are the knife generators. M-rotors and M-stators form pairs and must not be confused.

- V-Generator = V-Rotor + V-Stator
- F-Generator = F-Rotor + F-Stator
- N-Generator = F-Rotor + V-Stator
- M-Knifegenerator = Rotor M + Stator M

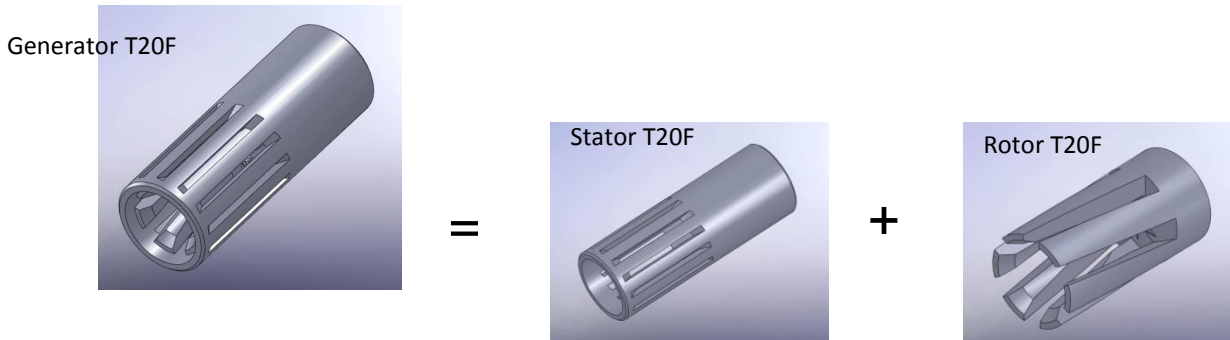

To create an **F-type generator** use an F-rotor plus an F-stator. This combination is suitable for aqueous media.

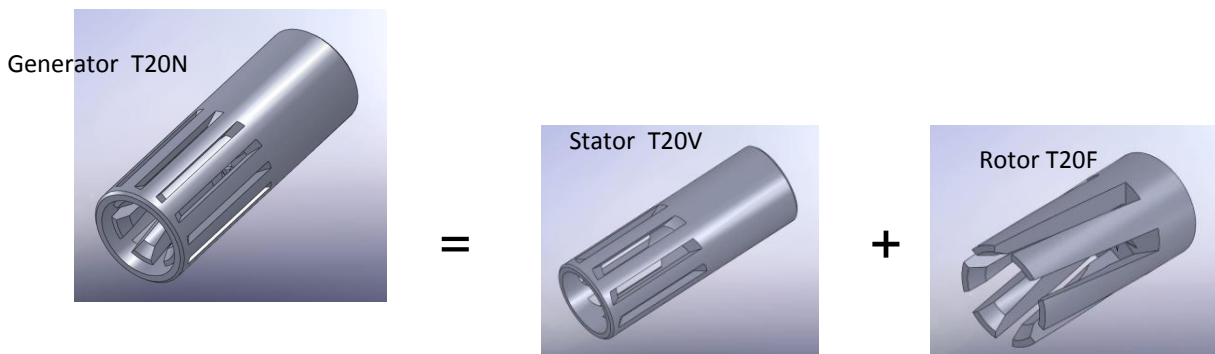

To create an **N-type generator**, use an F-rotor plus a V-stator. This combination is suitable for normal media.

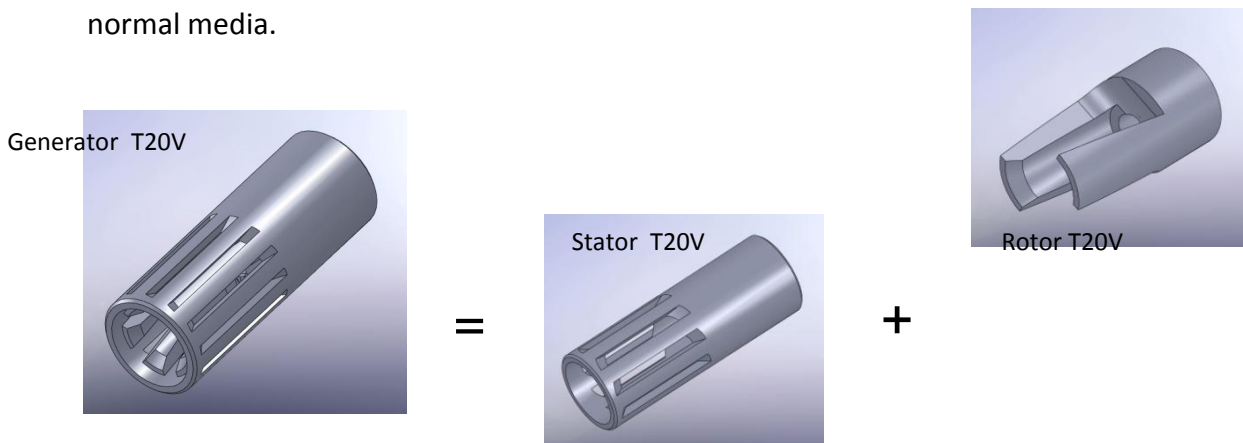

To create a **V-type generator** use a V-rotor plus a V-stator. This combination is suitable for coarse media.

## 4.2 Exchanging the Generator:



**CAUTION** The Generators (A) have sharp edges. Handle with care. Risk of injuries!

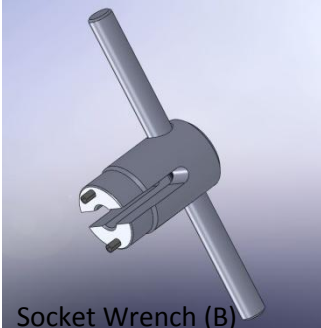

Socket Wrench (B)

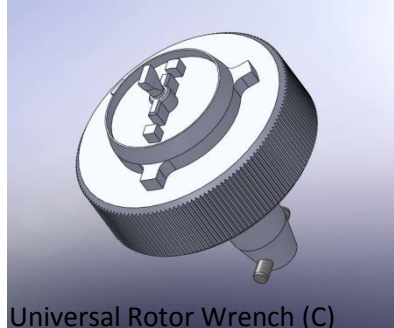

Universal Rotor Wrench (C)

For undoing the rotor (1), use the two special wrenches (to be ordered separately). The socket wrench (B) is used to counter-hold the Shaft, and the rotor wrench (C) to undo the rotor (1). To exchange the stator (2), remember that the fastening thread is **counter-clockwise**.

### **NOTICE**

*Always unscrew the rotor (1) first before unscrewing the stator (2).*

### 4.2.1 Disassembling Shaft T 6

Shaft T 6

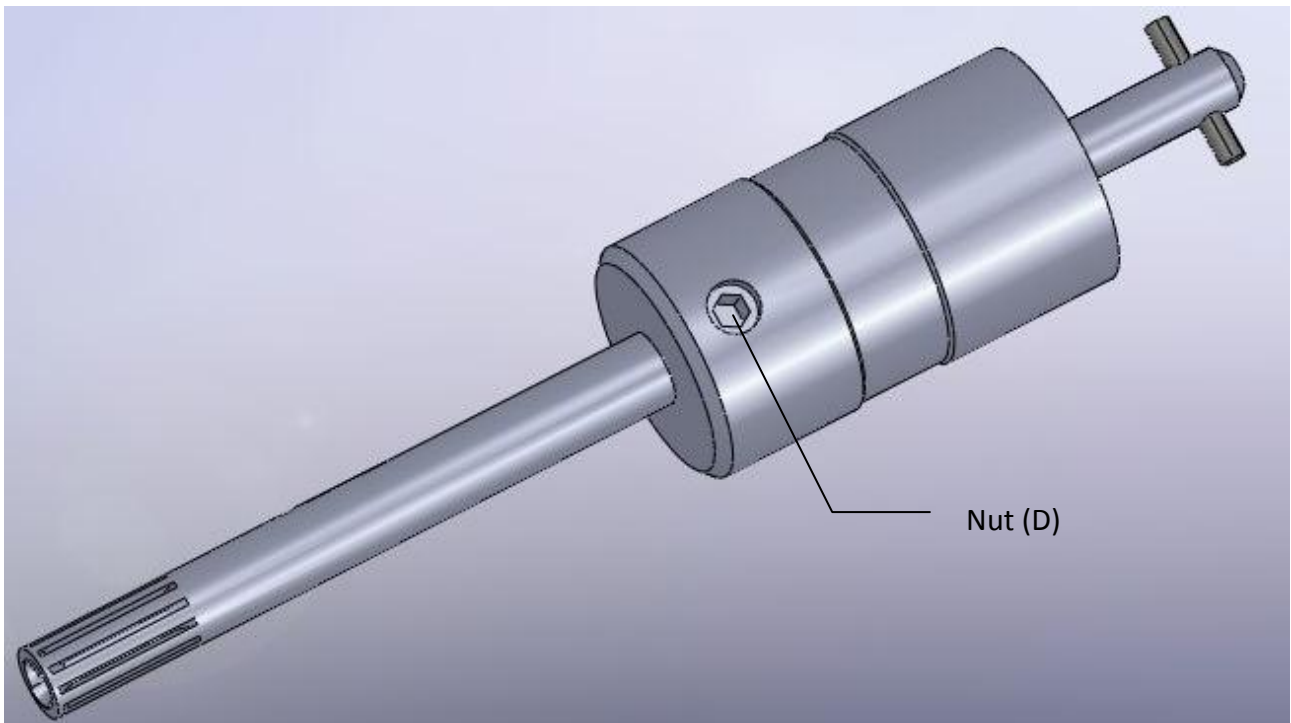

Bearing at the bottom of the shaft  
Lager am Schaffende

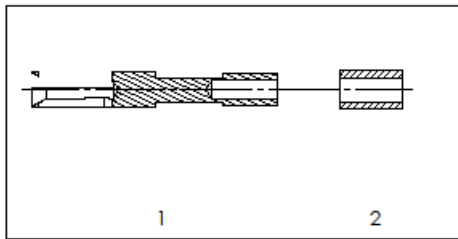

Bearing at the top of the shaft  
Lager antriebsseitig

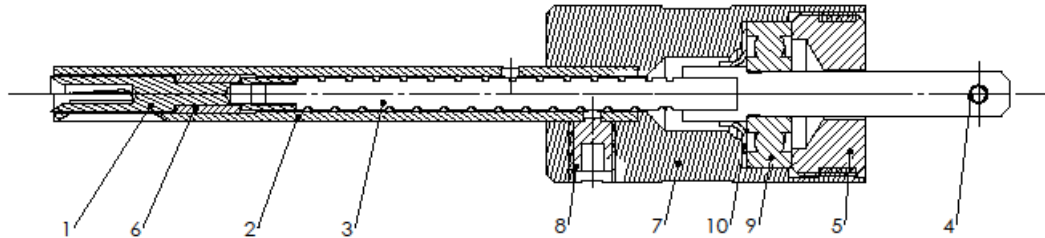
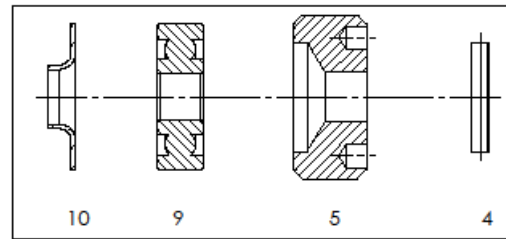

01 Rotor			
02 Stator			
03 Rotating Shaft	for 55 mm Shaft: PN: 10420-67	08 PTFE bearing	PN: 10420-69
	for 120 mm Shaft: PN: 10410-53	07 Shaft Tube Bearing	PN: 10420-60
04 Drive Pin	PN: 00421-50	08 Thread Pin	PN: 00420-54
05 Threaded Ring	PN: 10421-56	09 Ball Bearing	PN: 20421-50
		10 PTFE Disc	PN: 10421-70

The shaft comes always fully assembled. The socket wrench (B) is used to counter hold the rotating shaft (3) and to undo the nut (D). The rotor wrench (C) is used to loosen respectively to fasten the rotor (1). To loosen the stator shaft you need a 2.5 Allen key.

To disassemble the generator (A), carefully insert the rotor wrench (C) into the rotor (1). Now place the drive pin (4) located at the rotating shaft (3) into the socket wrench (B). Carefully turn to the left to unscrew the rotor (1).

The removal of the bearing is only necessary for cleaning or replacement purposes.

#### 4.2.2 Reassembling Shaft T 6

Before assembling, be sure the bearing is in place. Insert the socket wrench (B) on top of the shaft as explained above. Hold the shaft and socket wrench in one hand and screw the rotor (1) on clockwise (to the right). Tighten the rotor (1) using the rotor wrench (B).

Insert the shaft into the drive motor firmly with a "click". Tighten the shaft securely with the screw on the motor flansk.



**WARNING** NEVER change the rotor /stator while the shaft is attached to the motor!  
NEVER run the motor dry. ALWAYS insert the shaft into the media BEFORE turning on the motor!

### 4.2.3 Disassembling Shaft T 10/T 17

#### Shaft T 10/T 17

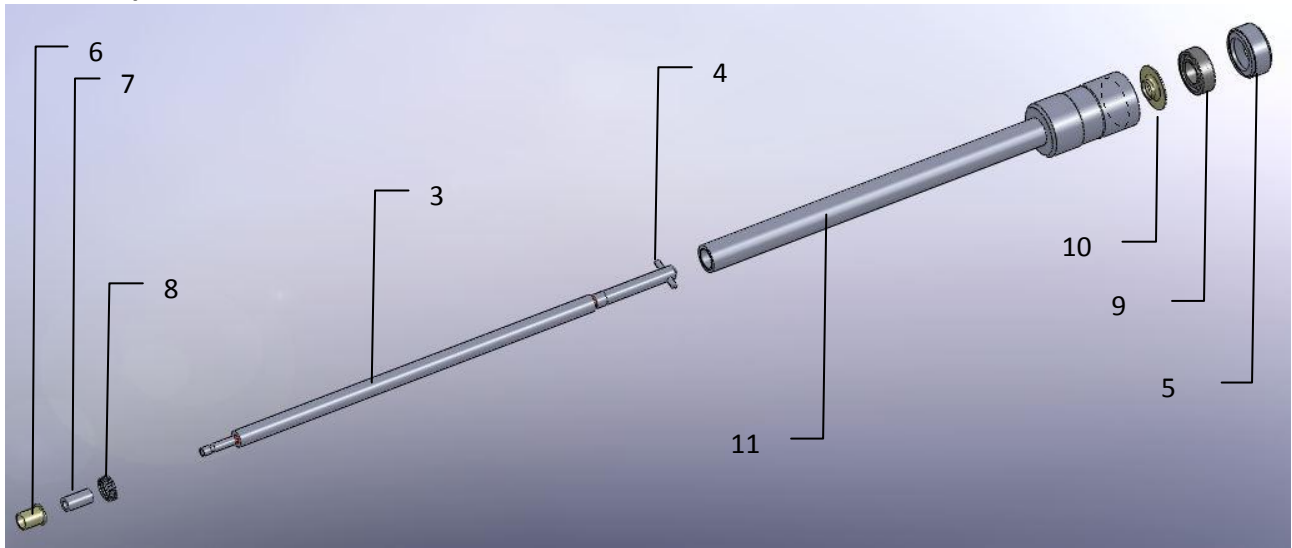

6 PTFE Bearing	PN: 10421-66	11 Shaft Tube	PN: 10421-54
7 Sliding Sleeve	PN: 10421-65	9 Ball Bearing	PN: 20421-50
8 Spring	PN: 20421-62	5 Threaded Ring	PN: 10421-56
3 Rotating Shaft	PN: 10421-64	10 PTFE Disc	PN: 10421-70
4 Drive Pin	PN: 00421-50		

The shaft comes always fully assembled. The socket wrench (B) is used to counter hold the rotating shaft (3) and to undo the nut (D). The rotor wrench (C) is used to loosen respectively to fasten the rotor (1).

To disassemble the generator (A), carefully insert the rotor wrench (C) into the rotor (1). Now place the drive pin (4) located at the rotating shaft (3) into the socket wrench (B). Carefully turn to the left to unscrew the rotor (1). Take care not to bend the teeth of the rotor (1). The stator (2) can now be unscrewed turning to the right by hand.

***Please note***

*Left hand thread.*

The PTFE bearing (6) can now be pulled out. The bearing section consists of two parts, the bearing itself and the shaft sleeve.

The removal of the bearing is only necessary for cleaning or replacement purposes.

### 4.2.4 Reassembling Shaft T 10/T 17

Before assembling make sure the bearing is in place. Screw on the stator (2) in counter clockwise direction. Insert the socket wrench (B) on top of the shaft as described under "disassembling". Hold the shaft and socket wrench (B) in one hand and screw on the rotor (1) (clockwise -to the right). Tighten the rotor (1) using the rotor wrench (C).

Insert the shaft into the drive motor firmly with a "click". Tighten the shaft securely with the screw on the motor flansk.



**▲WARNING** NEVER change the rotor /stator while the shaft is attached to the motor!  
NEVER run the motor dry. ALWAYS insert the shaft into the media BEFORE turning on the motor!

## 4.2.5 Disassembling Shaft T 20/T 30/T 40

### Shaft T 20/T 30/T 40

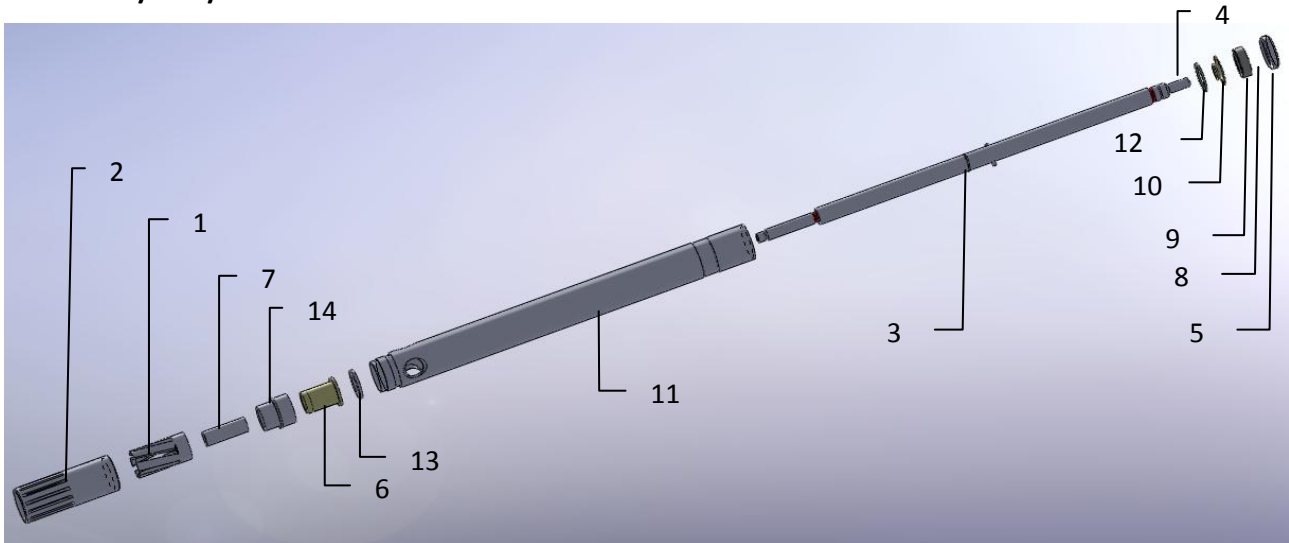

1 Rotor		3 Rotating Shaft	T 20/T 30: PN: 10422-52
2 Stator			T 40: PN: 10414-01
7 Sliding Sleeve	T 20/T 30: PN: 10422-51	12 Retaining Disc	PN: 20422-51
	T 40: PN: 10414-03	10 PTFE Disc	T 20/T 30: PN: 10422-62
14 Bearing Bushing	PN: 10422-50		T 40: PN: 10414-04
6 PTFE Bearing	PN: 10422-63	9 Ball Bearing	PN: 20422-52
13 Retaining Disc	PN: 20422-53	5 Threaded Ring	PN: 10422-55
11 Shaft Tube	T 20/T 30: PN: 10422-57	4 Drive pin (not shown in picture)	T 20/T 30: PN: 00422-51
	T 40: PN: 10414-02		T 40: PN: 00414-01
		8 Retaining Ring (not shown)	PN: 00422-52

#### 4.2.5.1 Disassembly of bearing at the bottom of the shaft

The homogenizer tool comes always assembled. To disassemble hold the shaft in one hand and unscrew the stator (2) clockwise (to the right). Insert the socket wrench (B) at the top of the shaft by placing the drive pin (4) into the large slot provided by the socket wrench. Turn the socket wrench (B) until the two small rods at the end of the socket wrench (B) go into the two small holes located at the top of the shaft. With one hand holding the shaft and the socket wrench take the rotor wrench (C) in the other hand and place the flat bar between the teeth of the rotor (1). Turn counter-clockwise (to the left). The rotor (1) now can be unscrewed easily. Now unscrew the stator (2) clockwise (to the right). The bearing now can be pulled out.

The removal of the bearing is only necessary for cleaning or replacement purposes.

The bearing assembly at the bottom of the shaft consists of four parts: Sliding sleeve (7), bearing bushing (14), PTFE bearing (6) and a retaining disc (13).

#### 4.2.5.2 Disassembly of the bearing at the top of the shaft

The bearing assembly at the top of the shaft consists of four parts. Retaining disc (12), PTFE disc (10), ball bearing (9) and threaded ring (5).

Reassemble the bearing in reverse sequence and securely fasten the threaded ring (5).

#### 4.2.6 Reassembling Shaft T 20/T 30/T 40

Before assembling make sure the bearing is in place. Screw on the stator (2) in counter clockwise direction. Insert the socket wrench (B) on top of the shaft as described under "disassembling". Hold the shaft and socket wrench (B) in one hand and screw on the rotor (1) (clockwise = to the right). Tighten the rotor (1) using the rotor wrench (C).

Insert the shaft into the drive motor firmly with a "click". Tighten the shaft securely with the screw on the motor flank.

**▲WARNING**

*NEVER change the rotor /stator while the shaft is attached to the motor!  
NEVER run the motor dry. ALWAYS insert the shaft into the media BEFORE turning on the motor!*

## 4.2.7 Disassembling Shaft G 20/G 30

### Shaft G 20/G 30

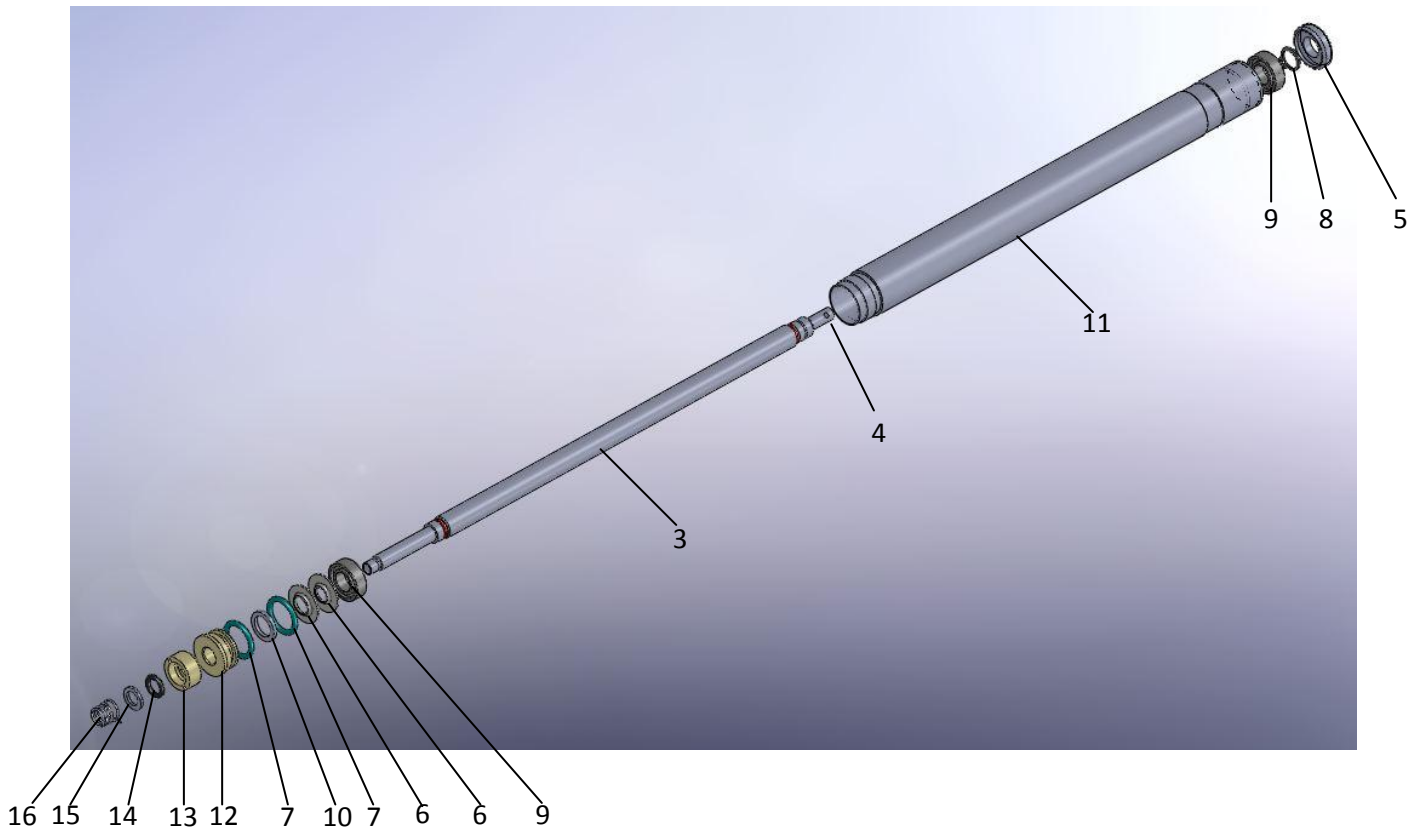

16 Spiral Spring	PN: 20423-59
15 Retaining Disc	PN: 20423-60
14 O-Ring	PN: 20423-58
13 Slip Ring	PN: 20423-57
12 Slip Disc	PN: 20423-56
7 O-Ring (x2)	PN: 20423-54
10 Spacer Disc	PN: 20423-55
6 PTFE Disc (x2)	PN: 10421-70
9 Ball Bearing	PN: 20422-52

3 Rotating Shaft 3-part	PN: 10423-53
4 Drive Pin (not shown in picture)	PN: 00422-51
11 Shaft Tube	PN: 10422-58
8 Retaining Ring	PN: 00422-52
5 Threaded Ring	PN: 10422-55

#### 4.2.7.1 Disassembly of bearing at the bottom of the shaft G 20/G 30

The homogenizer tool comes always assembled. To disassemble hold the shaft in one hand and unscrew the stator (2) clockwise (to the right). Insert the socket wrench (B) at the top of the shaft by placing the drive pin (4) into the large slot provided by the socket wrench (B). Turn the socket wrench (B) until the two small rods at the end of the socket wrench (B) go into the two small holes located at the top of the shaft. With one hand holding the shaft and the socket wrench (B) take the rotor wrench (C) in the other hand and place the flat bar between the teeth of the rotor (1). Turn counter-clockwise (to the left). The rotor (1) now can be unscrewed easily. Now unscrew the stator (2) clockwise (to the right). The bearing now can be pulled out. The removal of the bearing is only necessary for cleaning or replacement purposes.

The bearing assembly at the bottom of the shaft consists of eleven Parts: spiral spring (16), retaining disc (15), O-ring (14), ceramic slip ring (13), slip disc (12), O-ring (7), spacer disc (10), two PTFE discs (6) and a ball bearing (9).

#### 4.2.7.2 Disassembly of the bearing at the top of the shaft

The bearing assembly at the top of the shaft consists of three parts. Ball bearing (9), retaining ring (8) and threaded ring (5).

Reassemble the bearing in reverse sequence and securely fasten the threaded ring (5).

The unit comes always assembled. The socket wrench (B) is used to counter-hold the drive shaft (3). The rotor wrench(C) is used to unscrew respectively to fasten the rotor (1).

To disassemble the generator (A), carefully insert the rotor wrench (C) into the rotor (1) and place the drive pin (4) located at the drive shaft (3) into the socket wrench (B). Now carefully turn to the left to unscrew the rotor (1). Take care not to bend the teeth of the rotor (1).

The removal of the bearing should only be necessary for cleaning or replacement purposes.

#### 4.2.8 Reassembly of Shaft G 20/G 30

Before assembling make sure the bearing is in place. Screw on the stator (2) in counter clockwise direction. Insert the socket wrench (B) on top of the shaft as described under "disassembling". Hold the shaft and socket wrench (B) in one hand and screw on the rotor (1) (clockwise -to the right). Tighten the rotor (1) using the rotor wrench (C).

Insert the shaft into the drive motor firmly with a "click". Tighten the shaft securely with the screw on the motor flank.



**▲WARNING** NEVER change the rotor /stator while the shaft is attached to the motor!  
NEVER run the motor dry. ALWAYS insert the shaft into the media BEFORE turning on the motor!



## 4.2.9 Disassembling Shaft G 40

### Shaft G 40

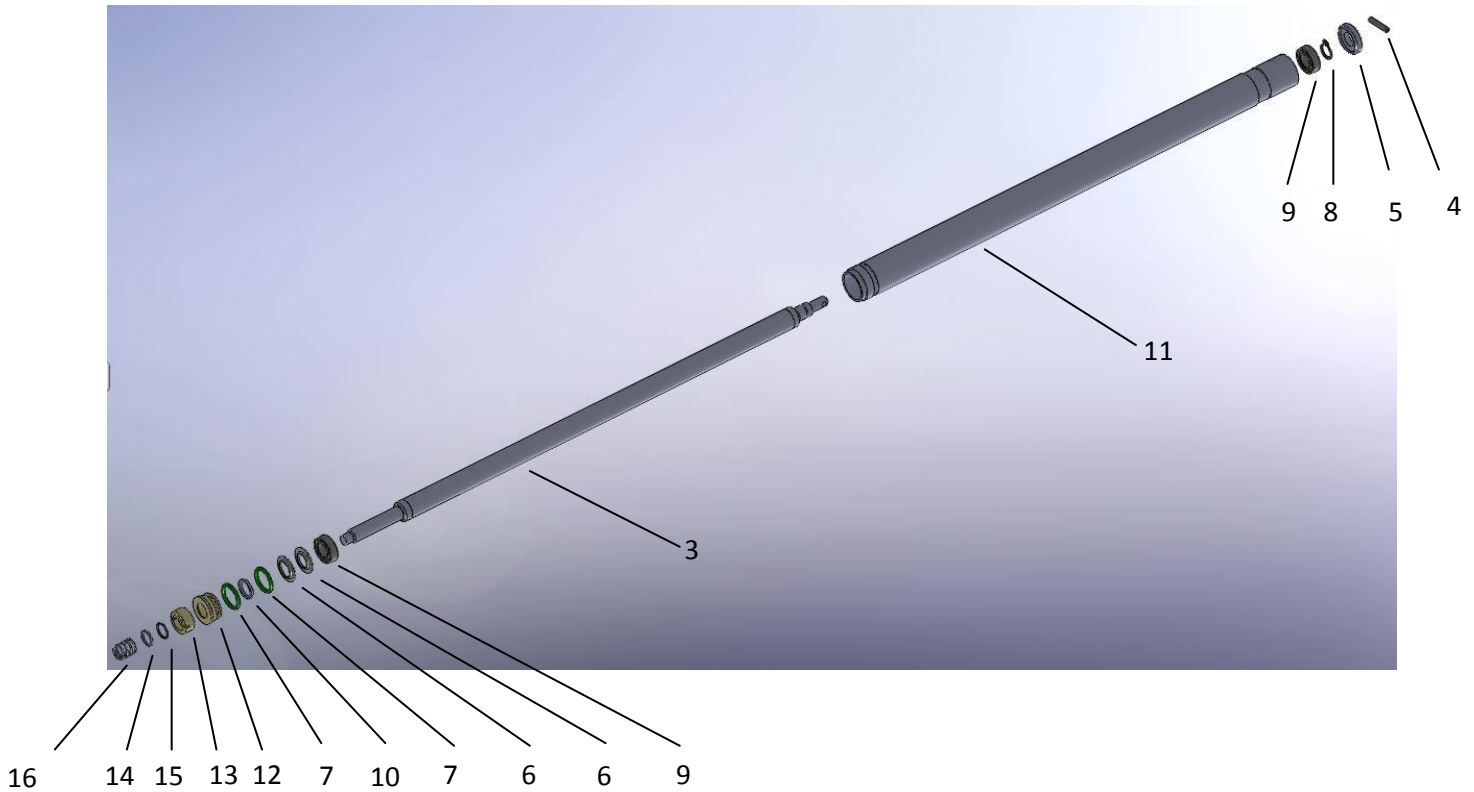

03 Rotating Shaft (three part)	PN: 10415-01	10 Spacer Disc	PN: 10415-03
04 Drive Pin	PN: 00414-01	11 Shaft Tube	PN: 10415-02
05 Threaded Ring	PN: 10422-55	12 Ceramic Slip Disc	PN: 20415-01
06 PTFE Gasket	PN: 10414-04	13 Ceramic Slip Ring	PN: 20415-02
07 O-Ring	PN: 20423-54	14 Slip Ring Disc	PN: 10415-04
08 Retaining Ring	PN: 00422-52	15 O-Ring	PN: 20415-65
09 Ball Bearing	PN: 20411-52	16 Spiral Spring	PN: 20415-03

#### 4.2.9.1 Disassembly of bearing at the bottom of the shaft G 40

The homogenizer tool comes always assembled. To disassemble hold the shaft in one hand and unscrew the stator (2) clockwise (to the right). Insert the socket wrench (B) at the top of the shaft by placing the drive pin (4) into the large slot provided by the socket wrench (B). Turn the socket wrench (B) until the two small rods at the end of the socket wrench (B) go into the two small holes located at the top of the shaft. With one hand holding the shaft and the socket wrench (B) take the rotor wrench (C) in the other hand and place the flat bar between the teeth of the rotor (1). Turn counter-clockwise (to the left). The rotor (1) now can be unscrewed easily. Now unscrew the stator (2) clockwise (to the right). The bearing now can be pulled out.

The removal of the bearing is only necessary for cleaning or replacement purposes.

The bearing assembly at the bottom of the shaft consists of eleven Parts: spiral spring (16), retaining disc (15), O-ring (14), ceramic slip ring (13), ceramic slip disc (12), two O-rings (7), spacer disc (10), two PTFE discs (6) and a ball bearing (9).

## 5 Maintenance and Cleaning

### 5.1 Cleaning the homogenising tool

**CAUTION**

The Generators (A) have sharp edges. Handle with care. Risk of injuries!

To avoid clogging of the shaft, clean shaft, generator and in case of G-shaft the sealing parts after each use. This is done by operating it in a solvent which dissolves substance residues and is not harmful to the gasket. This is usually sufficient to clean the Generator.

**Chemical sterilization** may be also a method. General-purpose disinfectants such as formalin, alcohol, etc. may be used. It is important to remove disinfectant residues with sterilized water.

**NOTICE**

Make sure that the bearings, O-rings and gaskets are resistant to solvents.

**Sterilization with moist heat:**

This denotes the use of a steam jet pressurized to 2 bars at 120°C.

### 5.2 Maintenance homogenizing tools

The gaskets in the homogenizing tools must be constantly monitored. In the event of leakage the suction effect of the rotating Shaft can cause the medium to penetrate as far as the drive unit. If liquid emerges from the side hole at the top of the Shaft tube stop work immediately and check the gaskets. The function of the Generators depends on the condition of the sharp edges on the rotor and stator. These edges may be blunted very quickly in abrasive media, reducing the effectiveness of homogenizing.

## 6 Transport and Storage

**Prior to transport:**

Place the instrument and its parts in its original packaging or another suitable container to protect it during transport. Close the packaging with adhesive tape.

Store the instrument in a dry environment. Please observe the specified conditions of the ambient (temperature and humidity).

Do not subject the instrument to mechanical shocks or vibration during transporting it.

In case you do not use the original packaging please mark the box with the following notes:

- Glass symbol (handle with care, fragile)
- Umbrella (keep dry)
- Content (list of content)
- Storage ambient:

Max. ambient temperature :RT to +40°C

Max. humidity: 80%

## 7 Disposal



Please dispose of used instruments and defective components at your local recycling collection point. Prior to disposal, sort according to materials: Metal, glass, plastic, etc. Also be sure to dispose of the packing material in an environmental-friendly manner.

## 8 Warranty and Liability

The manufacturer agrees to either repair, or replace, at the manufacturer's discretion, any defects in materials or workmanship which develop within 24 months of the delivery of this product to the original user. In the event of replacement, the replacement unit will be guaranteed for the remainder of the original twenty-four (24) months period or ninety (90) days, whichever is longer.

If this product should require service, contact your local distributor or manufacturer for necessary instructions.

This guarantee will not apply if the defect or malfunction was caused by accident, neglect, unreasonable use or fitness for a particular purpose, which extend beyond the description and period set forth herein.

The manufacturer's sole obligation under this guarantee is limited to the repair or replacement of a defective product and the manufacturer shall not, in any event, be liable for any incidental or consequential damages of any kind, resulting from use or possession of the product.

**▲WARNING**

The user has to determine, if the instrument is suitable for his specific application. If there are any further queries, contact your local dealer or the manufacturer direct.

## 9 Technical Data

### 9.1 Technical Data

Shaft Type	Generator Ø in [mm]	Shaft Length in [mm] incl. generator	Max. Immersion Depth in [mm]	Volume in [ml]	Materials
T 6	6	105	55	0.1 - 50	Stainless Steel, PTFE
T 6 long	6	170	120	0.1 - 50	Stainless Steel, PTFE
T 10	10	205	150	1.0 - 250	Stainless Steel, PTFE
T 17	17	205	150	5.0 - 1,000	Stainless Steel; PTFE
T 20	20	265	200	10.0 - 2,000	Stainless Steel, PTFE
G 20	20	265	215	10.0 - 2,000	Stainless Steel, Ceramics
T 30	30	255	190	30.0 - 5,000	Stainless Steel, PTFE
G 30	30	255	200	30.0 - 5,000	Stainless Steel, Ceramics
T 40	40	360	250	100.0 - 20,000	Stainless Steel, PTFE
G 40	40	360	280	100.0 - 20,000	Stainless Steel, Ceramics

### 9.2 Technical Data Rotors and Stators

Description	Teeth	Outer Ø in [mm]	Inner Ø in [mm]	Part no.
<b>Knife stator 6-M</b> for 55 mm shaft				61432-00
<b>Stator 6 V</b> for 55 mm shaft	7	6	4.2	60450-00
<b>Stator 6 F</b> for 55 mm shaft	11	6	4.2	60451-00
<b>Knife stator 6-M</b> for 120 mm shaft				61434-00
<b>Stator 6 V</b> for 120 mm shaft	7	6	4.2	60452-00
<b>Stator 6 F</b> for 120 mm shaft	11	6	4.2	60453-00
<b>Knife rotor 6-M</b>				61442-00
<b>Rotor 6 V</b>	2	4	-	60460-00
<b>Rotor 6 F</b>	4	4	-	60461-00
<b>Knife stator 10-M</b>				61436-00
<b>Stator 10 V</b>	7	10	8.15	60430-00
<b>Stator 10 F</b>	17	10	8.15	60431-00
<b>Knife rotor 10-M</b>				61446-00
<b>Rotor 10 V</b>	2	7.5	-	60440-00
<b>Rotor 10 F</b>	4	7.5	-	60441-00

Knife stator 17-M				61438-00
Stator 17 V	9	17	13.3	60438-00
Stator 17 F	13	17	13.3	60439-00
Knife rotor 17-M				61448-00
Rotor 17 V	2	12.5	-	60448-00
Rotor 17 F	6	12.5	-	60449-00
Knife stator 20-M				61450-00
Stator 20 V	9	20	16	60432-00
Stator 20 F	13	20	16	60434-00
Knife rotor 20-M				61460-00
Rotor 20 V	2	15	-	60442-00
Rotor 20 F	6	15	-	60444-00
Knife stator 30-M				61452-00
Stator 30 V	13	30	26	60435-00
Stator 30 F	17	30	26	60437-00
Knife rotor 30-M				61462-00
Rotor 30 V	3	25	-	60445-00
Rotor 30 F	6	25	-	60447-00
Knife stator 40-M				61455-00
Stator 40 V	13	40	35	60456-00
Stator 40 F	23	40	35	60457-00
Knife rotor 40-M				61465-00
Rotor 40 V	4	33	-	60466-00
Rotor 40 F	8	33	-	60467-00

## 10 Repairs



**▲WARNING** *When returning instruments for repair that have come into contact with hazardous substances, please:*  
*Fill in attached "Repair Return Form"*  
*Provide precise information on the relevant medium*  
*Take protective measures to ensure the safety of our receiving and maintenance personnel. Mark the package as appropriate for hazardous materials.*

## 10.1 Repair Return Form

CONTACT/USER INFORMATION	
Contact:	Phone No.
Fax No.	Email:
Billing:	Shipping:
Company	Company
Address	Address

INSTRUMENT INFORMATION		
Model	Serial No.	
Please describe all problems/malfunctions		
Operating Conditions (please fill in if applicable)		
Ambient Temp.	Humidity	Speed
Load	Volume	Viscosity
Temperature in °C	Sample Temperature	Operating Time
Sample Description*		

\*NOTE: If the instrument was exposed to hazardous material, it must be decontaminated BEFORE returning it to Goldleaf Scientific and an MSDS for hazardous material must be included with the instrument.

RETURN SHIPPING			
UPS <input type="checkbox"/>	Air Parcel Post <input type="checkbox"/>	Collect** <input type="checkbox"/>	Other** <input type="checkbox"/>

\*\*Your account number is required for UPS collect respectively the address and contact of your preferred forwarder if you choose any other transport means.

PACKAGING INSTRUCTIONS TO RETURN AN INSTRUMENT FOR REPAIR
---

- ✓ Remove all accessories (e.g. homogniser tools, stirring paddles) from the instrument
- ✓ Clean excess testing material off the instrument/accessory
- ✓ Include MSDS sheets for all hazardous materials used with this instrument
- ✓ Pack the instrument in its original box. If the box is not available, take care to wrap the instrument and accessories with enough material to support them.
- ✓ DO NOT send pedestal stand unless there is a problem with the upright rod, clamp or base. If there is a problem with the stand remove the upright rod from the base and individually wrap each item to avoid contact with the instrument. (Applicable for overhead stirrers and homogenisers.)
- ✓ Pack the instrument and related items in a strong box for shipping. Mark the outside of the box with handling instructions.

Example: "Handle with care" or "Fragile- Delicate Instrument"