



QUALITY... PLAIN & SIMPLE®

## Under-The-Dash Foot Operated Emergency Brake Installation Instructions

### General Installation Notes:

Please read these instructions completely before beginning the installation. If you have any questions, please call.

Before beginning the installation, disconnect the negative battery cable and use wheel chocks to block the vehicle's wheels.

Make sure the engine, transmission, body and frame are properly grounded. We recommend using anti-seize lubricant on all aluminum threads.

Refer to Fig. 1 and Fig. 3 for the component names. Fig. 2 lists the dimensions.

**This Emergency Brake is designed to work with Lokar Connector Cables (sold separately).**

The Foot Operated Emergency Brake comes assembled with 5/16"-24 x 1-1/2" bolts and non-locking nuts. The non-locking nuts will make the mock up and installation easier, but are to be used for convenience only and must be replaced with the supplied 5/16"-24 nylock nuts during the final installation.

**Step 1:** Decide exactly where and how you want to mount the Foot Operated Emergency Brake. The Emergency Brake has been designed so that it can be mounted either to the firewall and the dash, or to the side structure underneath the dash. The mounting brackets are adjustable so that the assembly can be mounted in an easy-to-operate position in almost any vehicle. The release rod is designed to be cut-to-fit. The release rod can be bent so that it will pull straight if the release knob is mounted higher than the bottom of the dash. It can also be removed and reinstalled on the opposite side of the Emergency Brake if necessary for your application.

**Step 2:** Hold the Emergency Brake assembly in position at the firewall or against the side structure under the dash. Mark the outline of the firewall mount slider bracket on the firewall or the side structure with a scribe, pencil, or marker. Remove the Emergency Brake assembly from the vehicle, and remove the firewall mount slider bracket from the main frame. Position the firewall mount slider bracket over the outline you marked under the dash. Mark the position of the three 5/16" mounting holes on the firewall, or the position of the two slotted holes on the side structure if you are using the side adjustment slots for mounting.

# Under-The-Dash Foot Operated Emergency Brake Installation Instructions

Building American Quality... With A Lifetime Warranty!®

TOLL FREE 1-877-469-7440 • tech@lokar.com • www.lokar.com

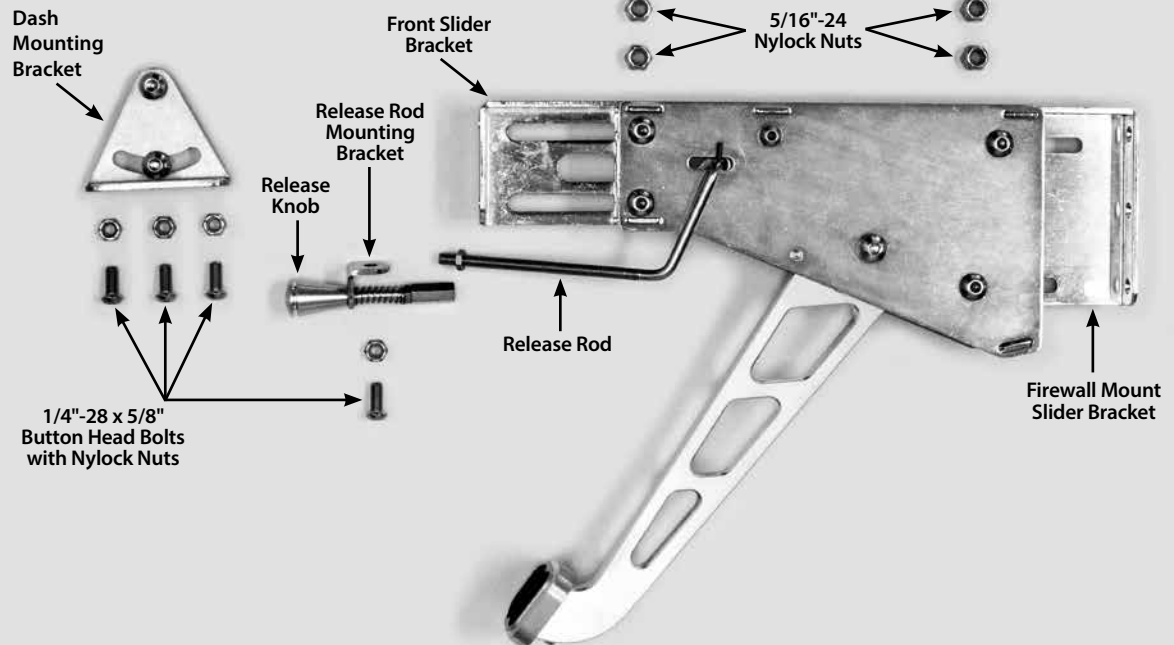

Fig. 1

**Step 3:** Center punch and drill the 5/16" holes in the firewall or side structure to mount the firewall mount slider bracket.

**Step 4:** Temporarily bolt the dash mounting bracket to the front slider bracket using the supplied 5/16"-24 x 1/2" button head bolts and nylock nuts.

**If you are NOT mounting the Emergency Brake to the side structure under the dash,** temporarily install the firewall mount slider bracket onto the Emergency Brake, using the 5/16"-24 x 1-1/2" button head bolts and non-locking nuts. Then, position the Emergency Brake in the vehicle and temporarily mount it to the firewall using 5/16" diameter bolts and nuts (not supplied, customer must determine correct length and type for their particular application).

**If you ARE mounting the Emergency Brake to the side structure of the dash,** position the firewall mount slider bracket and the Emergency Brake under the dash, and temporarily mount them in the vehicle using the supplied 5/16"-24 x 1-1/2" button head bolts and non-locking nuts.

**Step 5:** The dash mounting bracket has a curved slot in it that allows it to be mounted at an angle to fit most dashes. There are three mounting holes in the bracket to attach to the back of the dash, but it is only necessary to use one of them. Lokar has provided three 1/4"-28 x 5/8" button head bolts if you decide to use all three holes.

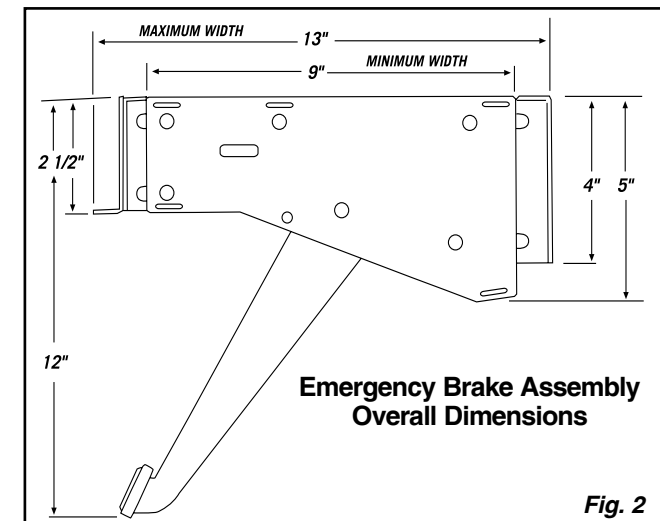

Emergency Brake Assembly Overall Dimensions

Fig. 2

## Under-The-Dash Foot Operated Emergency Brake Installation Instructions

**Step 5 (continued):** When looking at the Emergency Brake assembly from the driver's position, the hole on the right hand side of the dash mounting bracket may also be used to mount the release rod mounting bracket if you are not bending the release rod or relocating it to the other side of the Emergency Brake.

**NOTE: The release rod must be aligned parallel to the Emergency Brake when viewed from the top. If it is not, it will drag against the main frame and main frame cover.** Determine the best position for the dash mounting bracket, and mark the location of the mounting hole (or holes) on your dash. Drill the necessary 1/4" hole(s), and use the supplied 1/4"-28 x 5/8" button head bolt(s) and nylock nut(s) to temporarily mount the dash mounting bracket and the release rod mounting bracket to the dash.

**Step 6:** Once the firewall mount slider bracket and the dash mounting bracket are installed and the main frame is in its final position, the release rod can be cut to fit. Slip the release knob through the release rod mounting bracket, install the release rod spring, and adjust the jam nut up just enough to remove the slack and put some tension on the release rod spring. The release rod must not be loose. Position the release rod next to the release knob, and mark the release rod at the threaded end of the release knob. Remove the release rod from the Emergency Brake and cut the release rod at the mark. Deburr the threaded end.

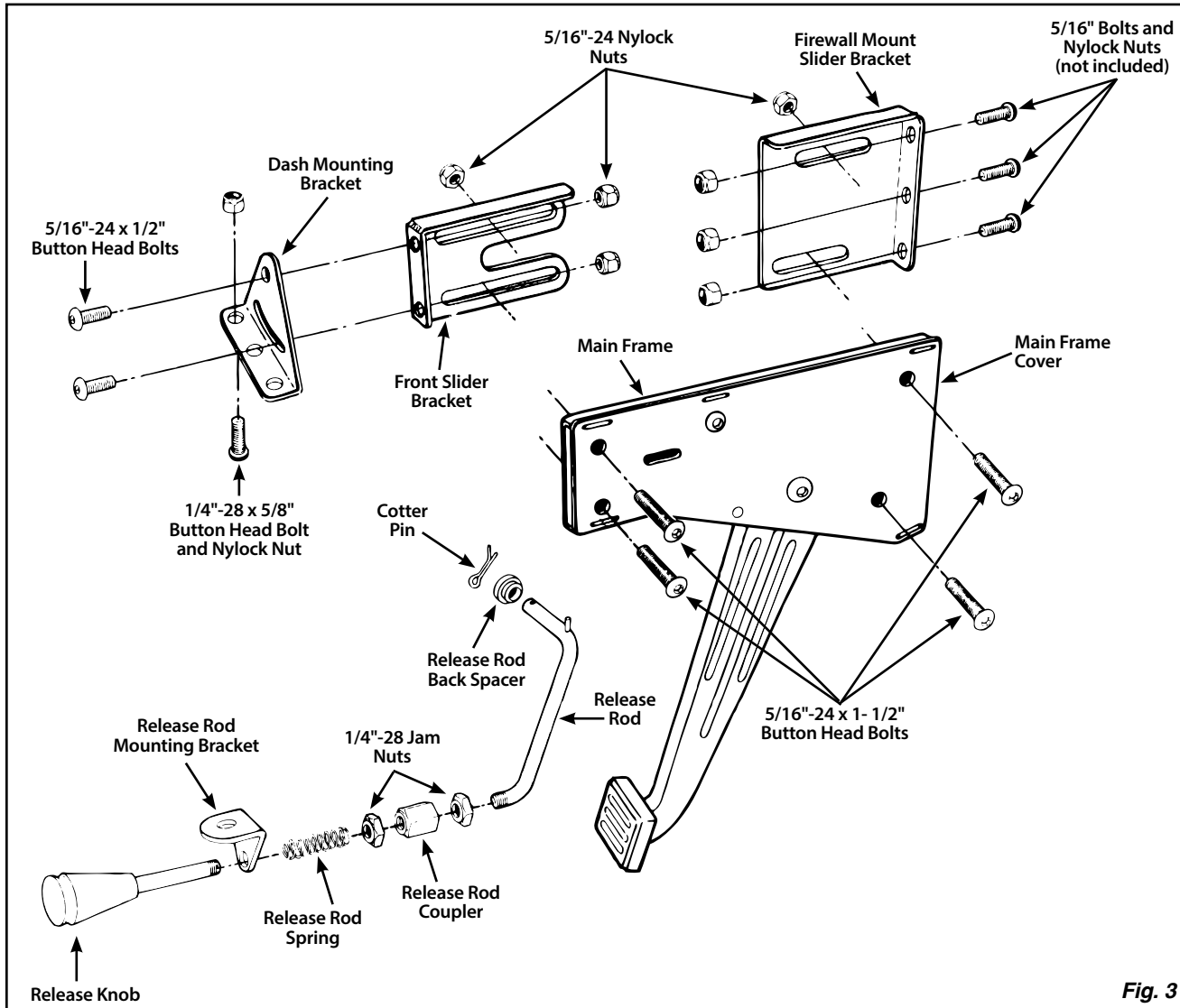

**Step 7:** Before the final installation of the release rod, remove the main frame assembly from the mounting brackets. Remove the two button head bolts and nylock nuts that remain in the assembly, and remove the main frame cover from the assembly. Install the Lokar Connector Cable (not included) following the instructions that are included with the Connector Cable.

**NOTE: The Connector Cable housing must be cut to length before the inner wire is installed.**

Once the Connector Cable housing has been cut to the correct length, install the Connector Cable inner wire into the clevis in the Emergency Brake.

**Step 8:** Position the main frame cover back onto the main frame. Reinstall the assembly into the vehicle, using the provided 5/16"-24 nylock nuts this time. Discard the non-locking nuts. Do not overtighten the nylock nuts, as this could distort the assembly and cause the pedal to bind.

**Step 9:** Route the Connector Cable underneath the vehicle and connect it to the Rear Emergency Brake Cables.

**NOTE: The Foot Operated Emergency Brake does not have its own return spring. It relies on the return springs on the Rear Emergency Brake Cables.**

**NOTE: In order to release the Foot Operated Emergency Brake, you must depress the pedal slightly while pulling on the release knob.**

### Main Frame with Cover removed showing Connector Cable installation

