

# WIREMASTER™

## Power Panel & Deluxe Wiring Kit

- Easy To Mount
- Compact Size
- 12 Fuses
- Hazard & Turn Flashers
- Horn Relay
- 32 Terminal Connections
- NEW Power Terminal
- 523 Feet GXL High Temp Wire
- 8 Gauge Charge Wires
- GM Color Coded
- Each Wire Labeled Every 12 Inches
- Panel Screw Terminals Numbered For Easy Installation
- Pre-Wired Headlight Circuit
- Dimmer Switch
- Pre-Assembled Turn Signal Switch Pigtail
- Pre-Assembled Ignition Switch Pigtail
- Pre-Assembled Neutral Safety Switch Pigtail
- Pre-Assembled Reverse Light Switch Pigtail
- Includes Circuits For
  - Reverse Lights
  - Electric Fuel Pump
  - Power Seats
  - Power Windows
  - Air Conditioning
- Sealed Beam Connectors Included
- 2-Wire Alternator Field Plug W/ Diode
- Generous Terminal & Goodie Bag



## Getting Started

### Mounting The Panel

The first step in completing your wiring project is to choose a mounting location for your Power Panel. We strongly suggest mounting the Power Panel in reasonably close proximity to the steering column and ignition switch. The panel can be mounted in any position that is practical but we suggest the inside of the firewall, inside the driver's kick panel or under the cowl. Driver's side is always preferable. In addition to installing the wiring, you will also want to be able to get to the fuses after the interior and upholstery is installed. Also consider that the ignition switch pigtail and the turn signal switch pigtail are approximately 36" long.

The panel is constructed with two ¼ 20 coupling nuts on the back to facilitate mounting.



A mounting template is included on page 21. The coupling nuts allow the panel to be mounted over firewall insulation if desired. Also included are two ¼ 20 stainless button head screws if you choose to drill through the firewall. If your firewall is smooth and hole-free, a sheet metal bracket can be fabricated to suspend the panel from interior cowl bracing. If desired, the coupling nuts can be removed and the panel can be mounted directly. It is also possible to screw the Power Panel to a piece of plywood and glue the plywood to the inside of the firewall or kick panel. A multi-purpose construction adhesive such as Liquid Nails provides a good bond and eliminates the need to weld on, or drill holes in, a painted firewall.

Once the panel is mounted, remove the terminal covers and the rubber Power Terminal Cover. We recommend keeping these parts in a plastic zip-lock bag so they can be re-installed when the project is completed. When the terminal covers are removed, you will notice that each terminal screw is numbered to simplify installation of the individual wires.

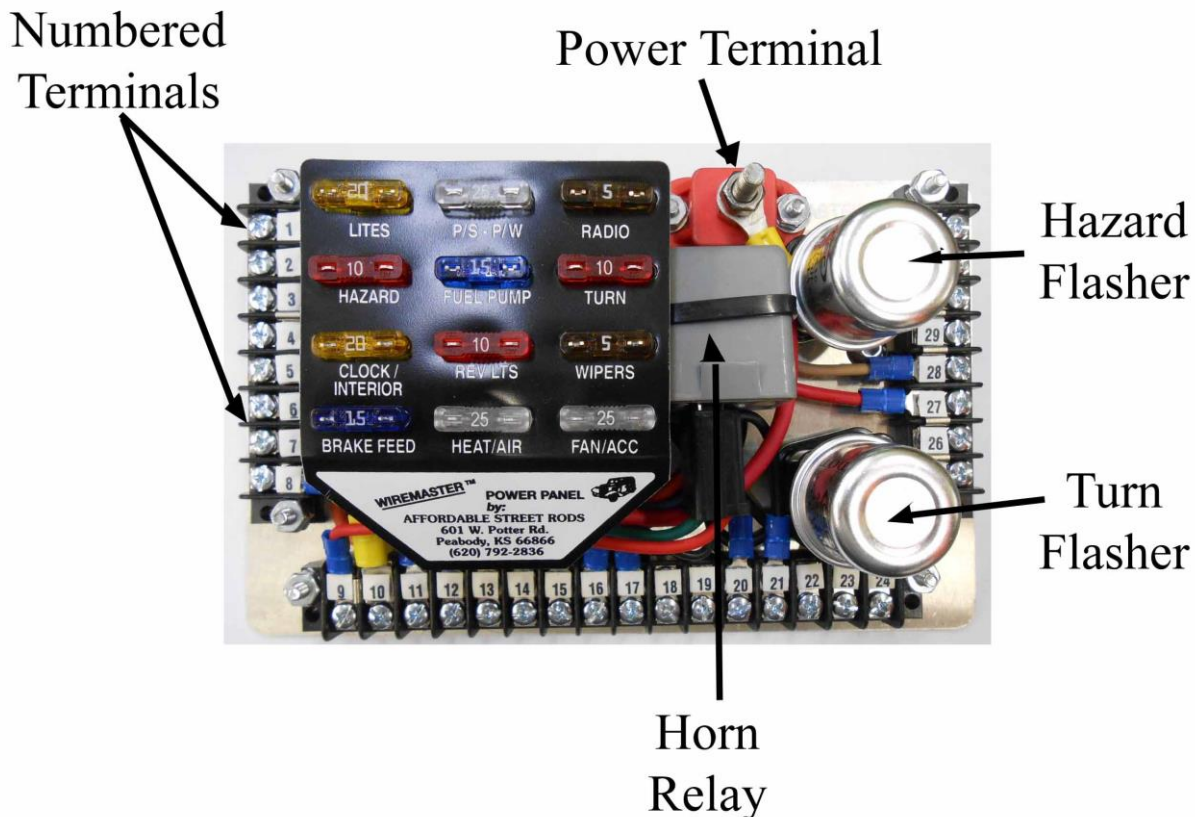

### Point A To Point B

With the panel mounted, the next step is to determine how you want to get wires from the inside of the car or truck to the engine compartment and beyond. We recommend drilling a 1 ¼" hole and installing a large grommet (Order Part # VIN33137-VUI) through the firewall, toe board or kick panel area. Spend some time thinking about the location of the hole/grommet before drilling. You will want to route wires away from exhaust heat, linkage movement and moving suspension components. You will also want to avoid potential wire chafing. On many cars, we install a large grommet on each side of the firewall and route wires under the dash rather than across the engine or firewall. Consider the location of your starter, alternator, oil and temp senders, etc. Under the hood, we recommend wrapping the wires with split loom to protect the wires and facilitate a tidy installation. Often a clean installation involves hiding the wiring to the maximum extent practical.

### Connecting The Wires To The Power Panel

Each wire in the wiring kit is tagged and numbered for ease of installation. In addition, each wire is printed every 12 inches. Once the panel is mounted and grommet(s) are installed to facilitate routing the wires, it is time to begin stringing wire. Neatness is a key component to any successful wiring project so we suggest routing the biggest wires first. Big wires are typically stiff and they will help keep smaller wires straight and tangle free as they are eventually bundled together into a harness.

The Power Terminal on your Power Panel is the best place to start. Connect wire #1 to the Power Terminal and route it through the grommet into the engine compartment toward your alternator. Next, connect wire #2 to the power terminal and route it through the grommet into the engine compartment to the general vicinity of your starter.

## Face Up / Face Down

Some of the numbered screws on the Power Panel will ultimately have more than one wire connected to them. A good rule to remember is to always install the wire terminals “Face Down” if possible.

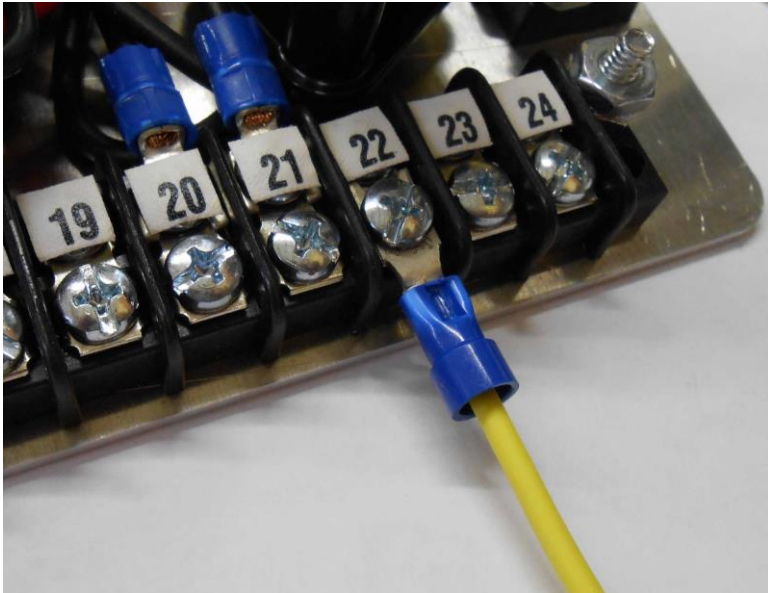

As you continue adding wires to the Power Panel, you will eventually find that a second wire may need to connect under the same numbered screw. If you installed the first terminal “Face Down” it will be simple to install the next terminal “Face Up.” It should not be necessary to install more than two terminals under the same numbered screw on the panel.

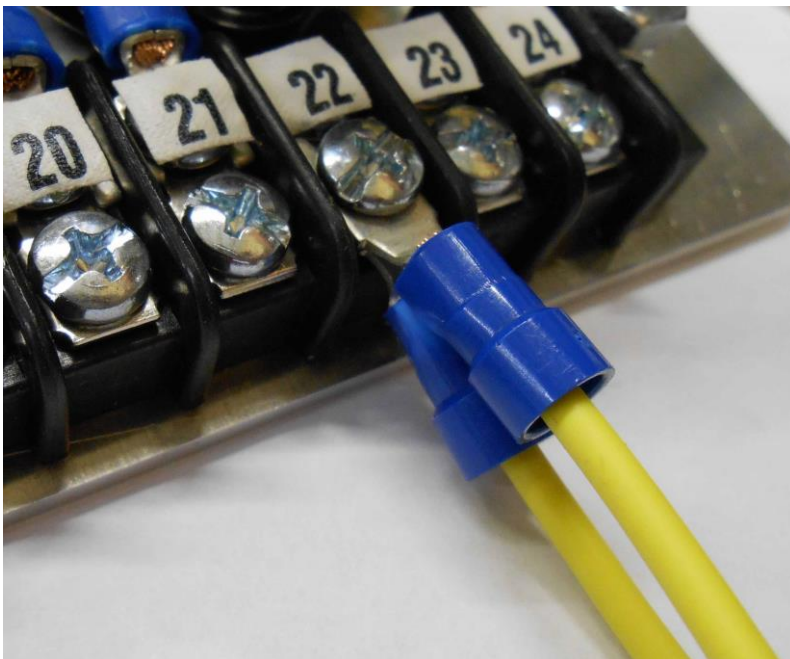

In the picture above, you will notice that the first wire installed on Terminal #22 is the Rear Left Turn wire and it is installed “Face Down.” The second wire installed on Terminal #22 is a part of the Turn Signal Switch Pigtail and it is installed “Face Up.”

## Neatness Counts

When we install this wiring kit in our shop, we like to bundle the wires neatly and compactly as we route them away from the panel. We suggest bending the wires in a hard 90 degree bend right at the plastic sleeve on the fork terminal. This saves valuable space and makes for a neat installation.

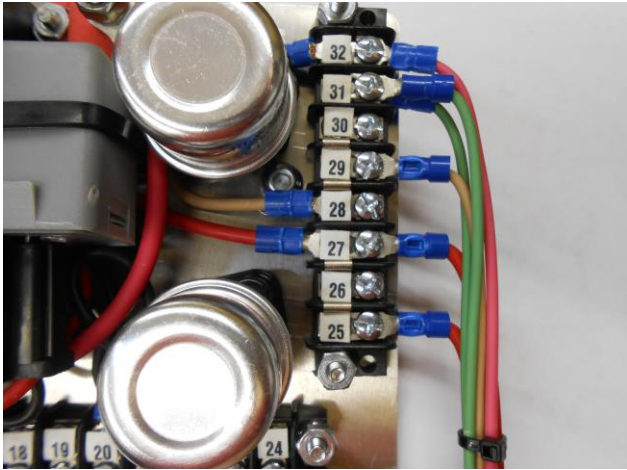

Don't cut anything to length yet. Route all of the wires from the Power Panel to the vicinity of their destination and then begin bundling them neatly, starting at the Power Panel. When you have the wires neatly bundled and routed the way that you want them, you will be ready to begin cutting and connecting. We like to terminate and connect wires closest to the Power Panel first and work our way to the front and rear of the car. Working from the panel to the front and rear simplifies the process of creating neat wire bundles.

## Crimping Terminals On To Wires

All of our terminal ends are machine crimped to the wires in your wiring kit. This works great in a manufacturing setting but it isn't practical in your home shop. We have experimented with many styles of crimping pliers over the years and some work better than others. The best tool that we have found for crimping terminal ends is a Klein #1006 crimping pliers.

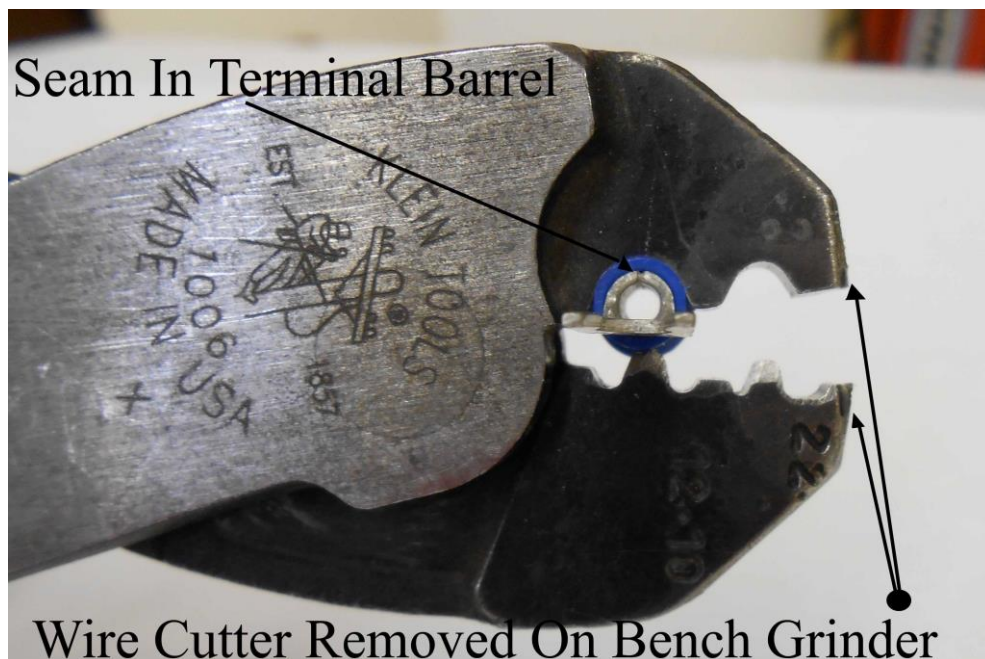

There are a couple of things to note in the previous photo. These pliers come with a wire cutter on the end that we remove with a bench grinder. These pliers produce a superior crimp but we find that it is pretty easy to inadvertently cut one wire while crimping another. Also note how the terminal end is positioned in the pliers. Place the terminal in the jaws so that the seam in the terminal barrel is in the concave jaw. This method of crimping insures a tight trouble-free crimp.

We are often asked about soldering terminal connections. While there is nothing wrong with soldering, a quality crimp such as described above produces excellent results.

### **Installing The Pigtails**

There are four pigtails included in the wiring kit. The pigtails are pre-bundled wires that connect the Power Panel to various switches. We recommend installing the pigtails after the individual wires are routed and bundled.

### **Neutral Safety Pigtail**

This pigtail simply connects terminals #6 and #7 on the Power Panel to the two terminals on your Neutral Safety Switch. On most column-shift cars, the neutral safety switch is located on the column. Some floor-shift automatic transmissions have the neutral safety switch located inside of the console. Many Mopar transmissions use a neutral safety switch that is built into the transmissions and it requires use of a relay. Call us and ask for (Part # WRM20102) to order a Mopar Neutral Safety Switch Relay Kit.

On Manual transmission cars and trucks, we suggest installing one of our brake switches (Part # WRM30101) on the clutch pedal mechanism. This requires that the clutch pedal must be depressed before the engine will turn over. **DO NOT OPERATE A CAR OR TRUCK WITHOUT A PROPERLY FUNCTIONING NEUTRAL SAFETY SWITCH!**



Pictured above is a Flaming River column-shift column with a combo neutral safety switch and reverse light switch. Stock GM column-shift columns will use a similar switch.

## Reverse Light Switch Pigtail

If your car or truck does not have reverse lights, you may skip this section.

The Reverse Light Switch Pigtail connects terminals #31 and #32 on the Power Panel to the two terminals on your reverse light switch. GM column-shift cars combine the neutral safety switch with the reverse light switch as pictured above.

On some cars, the owner will opt for a Lokar automatic floor shift which has a built-in neutral safety switch but find that they still need a reverse light switch. Lokar also makes a transmission-mounted reverse light switch for most GM transmissions (Part#LOKBL1400U). The LOKBL1400U switch also works as a neutral safety switch but it can only do one task or the other. Call us to order (Part #LOKBL1400U) if you have a GM automatic transmission and you need a transmission-mounted reverse light switch or neutral safety switch.

## Steering Column Pigtail

The Steering Column Pigtail is a vital component in connecting the Power Panel to the steering column turn signal switch. If you have a '77 or later GM steering column or an after-market steering column (other than Ididit) installation will be very simple.

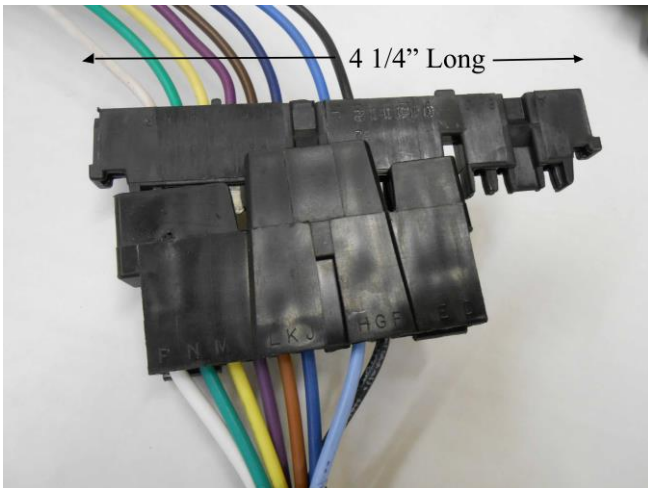

The photo above shows the long flat steering column connector that is present on '77 or later GM columns as well as most after-market columns (except Ididit). The flat connector is 4 1/4" long. If your column has this connector, simply plug the Steering Column Pigtail to the column. Make sure that terminal "P" on the female connector aligns with terminal "P" on the male connector and the wire colors should match.

If you have an IDIDIT column, pre-1977 GM column, or any other steering column, a 4 1/4" flat steering column connector and steering column brass terminals are included in your wiring kit and can be installed easily. Start by cutting the connector off of your column. Strip 1/4" of insulation from the end of each wire. If your column has turn signals, hazard switch and a horn button, you should have 8 wires to fit into the 4 1/4" connector.

If you are using a Universal Clamp-On Turn Signal Switch, call to order (Part #WRM-20103). This kit connects your Universal Clamp-On Turn Signal Switch to the Power Panel II.

We also offer a three-position toggle switch kit for turn signals. The switch can be mounted on or under the dash to keep the steering column clean. Order (Part #WRM-20105) The kit also includes a hazard toggle.

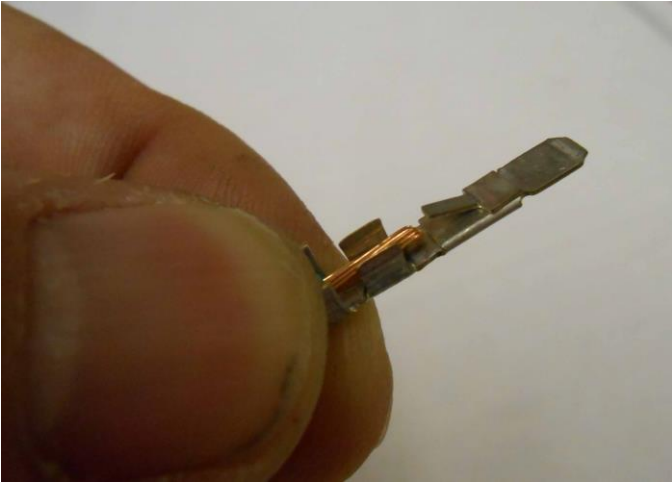

The photo above shows a steering column wire with ¼” of insulation stripped and the steering column connector brass terminal held in place.

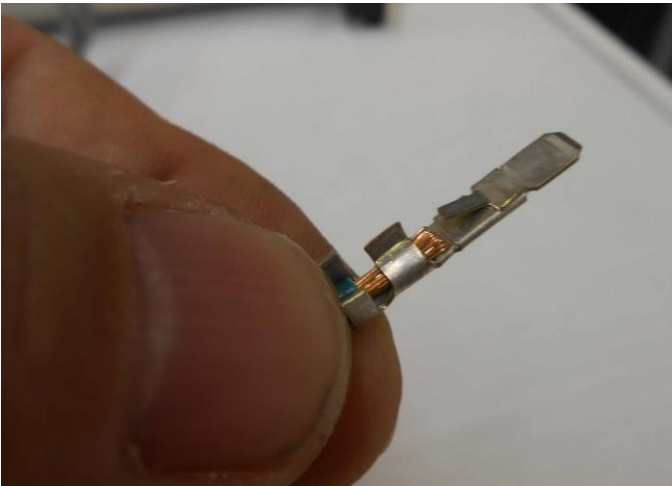

Start crimping the steering column connector brass terminal onto the wire by folding one forward ear over the stripped wire.

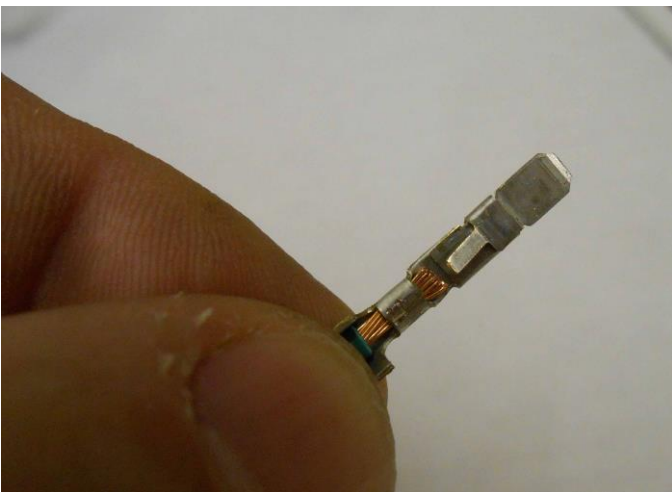

Next fold the second forward ear over the previously folded ear.



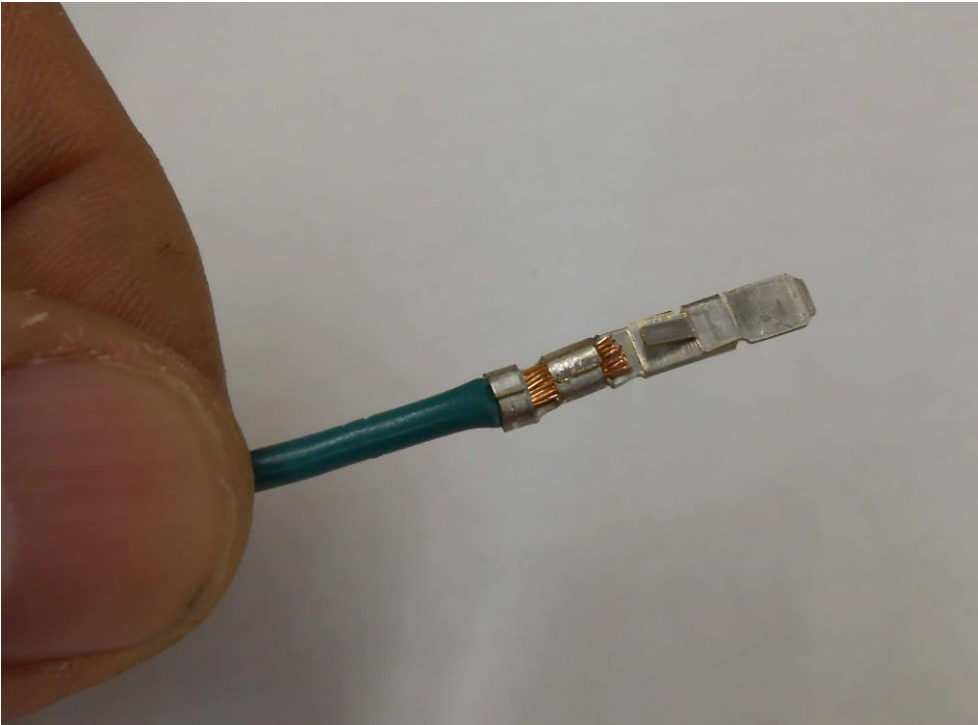

Finally, fold the two rear ears over the insulation and firmly crimp both sets of ears securely to the wire.

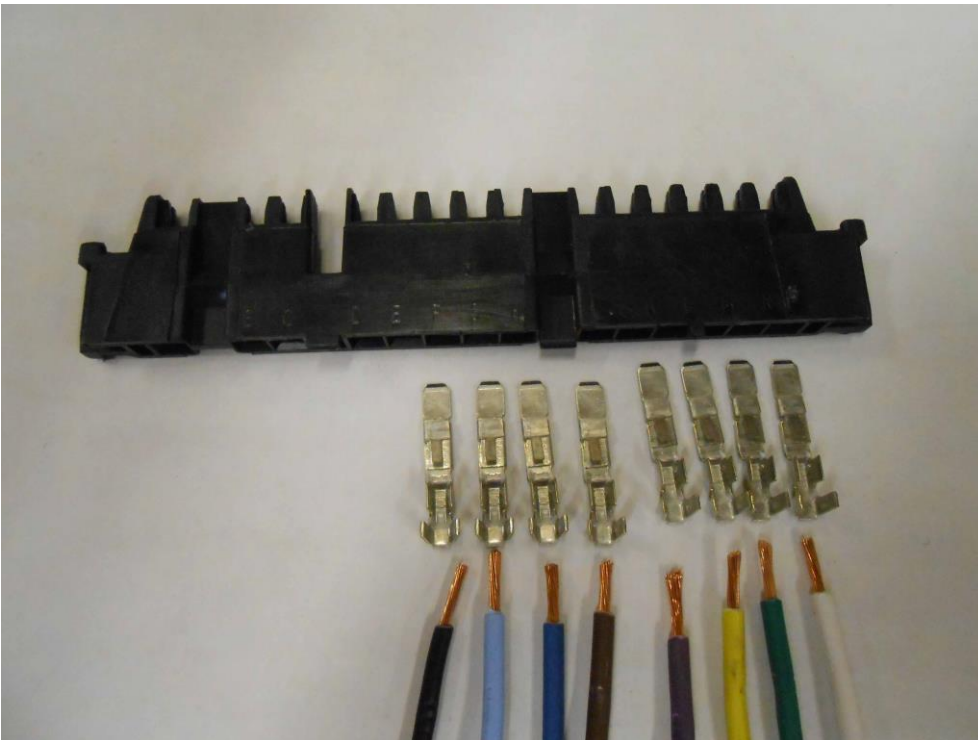

The photo above shows the eight wires from the steering column stripped and ready for installation of the steering column connector brass. With brass terminals crimped to each of the wires, insert them into the connector as follows: White = P, Green = N, Yellow = M, Purple = L, Brown = K, Dark Blue = J, Light Blue = H, Black = G.

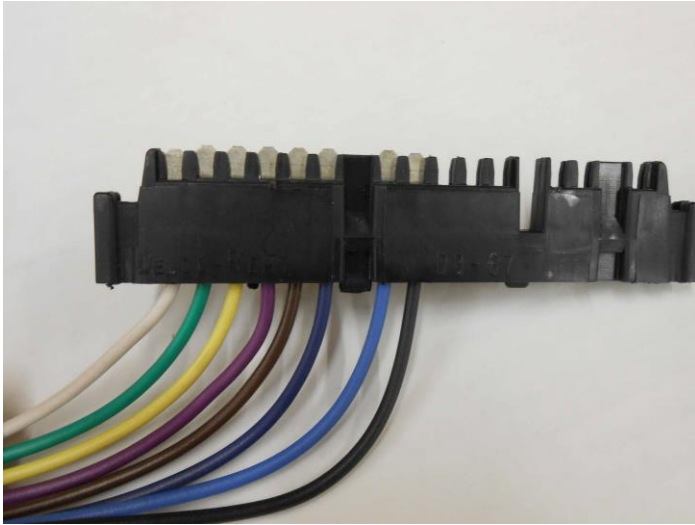

The photo above shows the 4 1/4" male steering column connector properly installed on the steering column wires.

With the steering column pigtail plugged into the steering column, you may cut the pigtail to length. Be sure to leave enough wire so that the pigtail can be neatly routed away from brake pedal, clutch pedal and gas pedal movement.

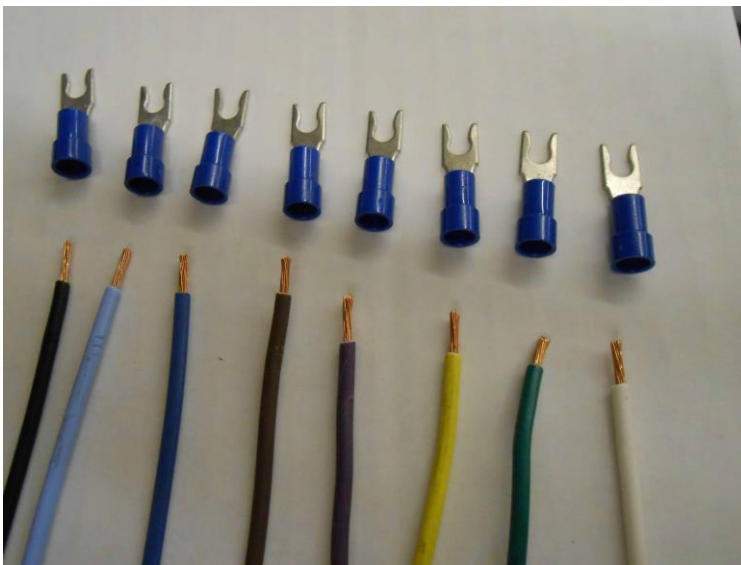

With the steering column pigtail cut to length, strip and crimp one blue fork terminal onto each of the wires and connect the steering column pigtail to the Power Panel in the following sequence: Black = #17, Light Blue = #18, Blue = #19, Brown = #20, Purple = #21, Yellow = #22, Green = #23, White = #24. We suggest using zip ties to hold the pigtail securely in its final location.

### **Ignition Pigtail**

The ignition pigtail consists of five wires. Install the ignition pigtail by first connecting the Red 10 Gauge wire to the Power Terminal on the Power Panel. Next, connect the pink wire to terminal #4 and the purple wire to terminal #7. Finally, connect the brown wire to terminal #11 and the orange wire to terminal #12.

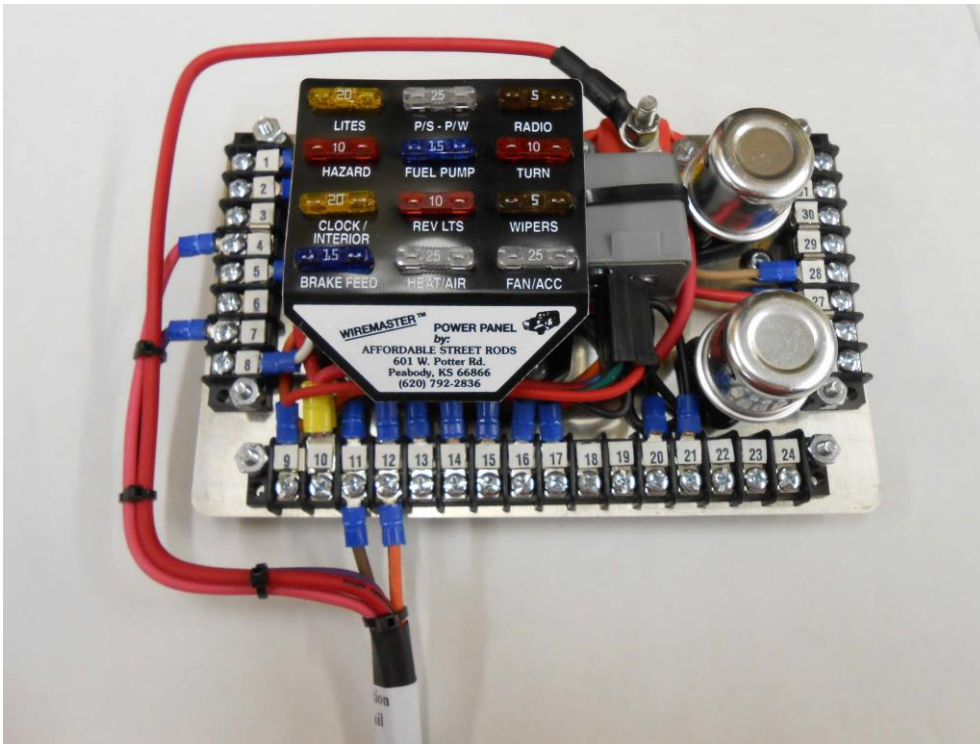

With the Ignition Pigtail connected to the Power Panel, the pigtail can be cut to length. Be sure to leave enough length to avoid potential chafing against brake, clutch and gas pedal mechanisms.



Our universal ignition switches (Part # WRM 30100) have screw terminal connections. The photo above shows ring terminals installed on the five ignition pigtail wires. Other switches may require other types of terminals.

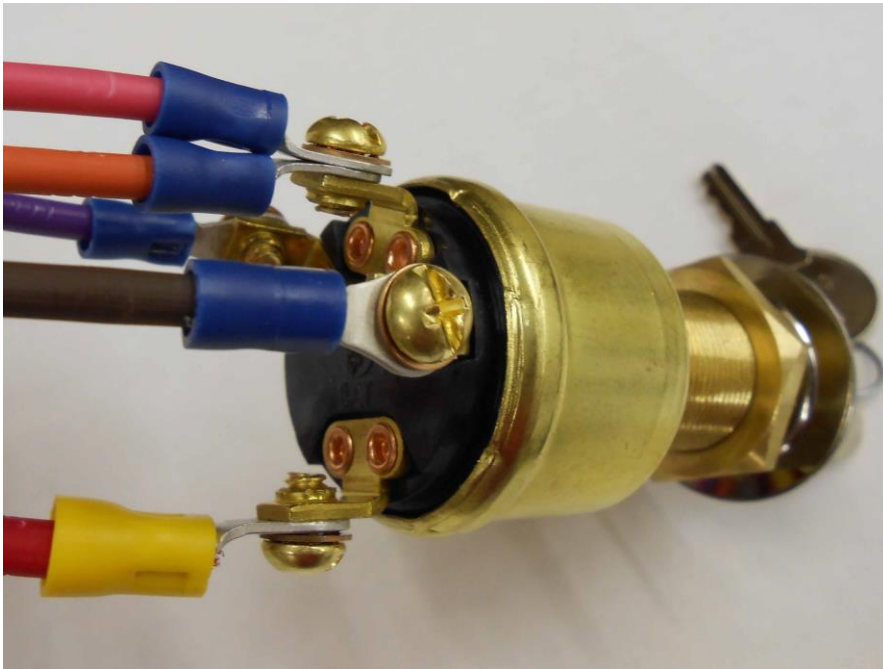

Notice that our universal ignition switch (Part # WRM30100) has four terminals on the back. Most universal ignition switches only have four terminals so you will need to install the orange and the pink ignition pigtail wires together on the IGN terminal. Remember “Face Down/Face Up” works best. Connect the Red 10 Gauge wire to the BATT terminal, the Brown 12 Gauge wire to the ACC terminal and the Purple 12 Gauge wire to the ST terminal. Your universal ignition switch is now ready to install in your dash or console.

### **GM Key-On-Column**

If you are using a GM steering column with the ignition switch on the column, give us a call and order (part # WRM20101). GM Key-On-Column ignition switches require two separate hot wires. If you are using that style of column, you will use terminal #10 on the Power Panel as the secondary power source for your ignition switch. (Part #WRM20101) includes everything that you will need to make your Key-On-Column ignition switch work and includes some handy instructions.

## **The Panel**

The Power Panel does not need to be grounded. It works just fine even mounted directly onto a fiberglass firewall.

**Power Terminal:** serves as a junction point to connect the alternator to the battery (Battery Terminal On Starter) as well as providing 12 Volt power to the Power Panel and the ignition switch.

**Terminal #1 Clock / Interior Lights:** Constant 12Volt power. This terminal is fuse protected via the "Clock/Interior" fuse and is "Battery Hot" meaning that it is always hot regardless of the ignition switch position. Use this terminal to power interior courtesy lighting, the clock and as a constant 12 Volt source for the radio.

**Terminal #2 Radio:** Switched 12 Volt power. This terminal is fuse protected via the "Radio" fuse and is only hot when the key is in the accessory, run or start position. Use this terminal for switched 12 Volt power for the radio.

**Terminal #3 Ignition:** Switched 12 Volt power. This terminal is not fused but is fed by the ignition switch. It is hot only when the key is in the run and start position. Use this terminal to power your ignition system. It can also be used as a "Key-On" hot terminal for the engine computer.

**Terminal #4 Ignition Feed:** Switched 12 Volt power. This terminal is not fused but is fed by the ignition switch. It is hot only when the key is in the run and start position. Use this terminal to power instruments and to provide field voltage to your alternator.

**Terminal #5 Lights:** Constant 12 Volt power. This terminal is fuse protected by the "Lights" fuse and is "Battery Hot." This terminal provides power to your headlight switch.

**Terminal #6 Neutral Safety SW:** This terminal is simply a junction point for connecting two wires. One of the wires (Purple 12 Gauge) goes to the Neutral Safety Switch and the other (also 12 Gauge Purple) goes to the starter solenoid. Terminal #6 simply connects these two wires.

**Terminal #7 Neutral Safety SW:** This terminal is simply a junction point for connecting two wires. One of the wires (Purple 12 Gauge) goes to the Neutral Safety Switch and the other (also 12 Gauge Purple) goes to the ignition switch. Terminal #7 simply connects these two wires. When the ignition switch is in the start or crank position, current travels from the ignition switch to Terminal #7. From Terminal #7 it goes to the Neutral Safety Switch. If the car is in park or neutral, the Neutral safety switch passes the current back to Terminal #6. From Terminal #6, current travels to the starter solenoid and the starter cranks the engine.

**Terminal #8 Brake Feed:** This terminal is fuse protected by the "Brake Feed" fuse and is "Battery Hot." Use this terminal to power the brake light switch.

**Terminal #9 Batt Feed:** As you might guess, this terminal is not fused and it is "Battery Hot." Chances are that you will not use this terminal but it is pretty handy for us as a connection point when we are assembling the panel.

Terminal #10 Batt Feed: This terminal is not fused and it is “Battery Hot.” Chances are that you will not use this terminal unless you have a GM steering column with the ignition switch on the column. If that applies to you, give us a call and order (part # WRM20101). GM Key-On-Column ignition switches require two separate hot wires. If you are using that style of column, you can use this terminal as the secondary power source for your ignition switch. Part #WRM20101 includes everything that you will need to make your Key-On-Column ignition switch work and includes some handy instructions.

Terminal #11 Accessory Feed 1: This terminal serves as a point where power can be introduced back into the Power Panel. When the ignition switch is in the run position and accessory position, power is transmitted through terminal #11 to feed the Radio, Turn, Wipers and Fan/Acc fuses.

Terminal #12 Accessory Feed 2: This terminal also serves as a point where power can be introduced back into the Power Panel. When the ignition switch is in the run position, accessory position, or start position, power is transmitted through terminal #12 to feed the Fuel Pump, Rev LTS and Heat/Air fuses.

Terminal #13 Heat/Air: This terminal is fuse protected by the “Heat/Air” fuse and is fed by Terminal #12. Terminal #13 is hot when the ignition key is in the Run, Accessory and Start positions. Use this terminal as a key-on power source for your Vintage Air relays or for blower switch power for your heater.

Terminal #14 Fan/Acc: This terminal is fuse protected by the “Fan/Acc” fuse and is fed by Terminal #11. Terminal #14 is hot when the ignition key is in the run and accessory positions. Use this terminal as a key-on power source to arm your electric fan relay if you are also using a block sender or adjustable fan thermostat. Remember, this terminal is hot when the ignition key is in the accessory position. If you turn your ignition switch to accessory so that you can listen to the radio, your fan relay will be armed and your cooling fan will run also. A block sender or adjustable fan thermostat will only allow the fan to run until the engine/radiator cools down. If you never want your cooling fan to run with the ignition key in the accessory position, use Terminal # 28 or Terminal #30 as the key-on power source to arm your cooling fan relay. Our 70 AMP cooling fan relay is (part #WRM-20106) **DO NOT CONNECT THIS TERMINAL DIRECTLY TO A COOLING FAN. USE A RELAY.**

Terminal #15 Wiper: This terminal is fuse protected by the “Wipers” fuse and is fed by Terminal #11. Terminal #15 is hot when the ignition key is in the run and accessory positions. Use this terminal as a power source for your windshield wiper system. On many OEM wiper systems, power is connected to the wiper motor and the wiper switch grounds the field windings to produce various wiper speeds. On most after-market wiper systems, power is connected to the wiper switch and the wiper motor is permanently grounded.

Terminal #16 Horn: This terminal is not fused but rather it is powered by the horn relay that is built into your Power Panel. Use this terminal to connect directly to your 12 volt horn. This terminal is only hot when Terminal #17 is grounded.

Terminal #17 Horn Button: This terminal receives a ground signal when your horn button is depressed. The ground signal closes the horn relay and current is passed to the horn. Connect this terminal to your horn switch/horn button.

Terminal #18 Left Front Turn Signal: This terminal serves only as a junction point to connect the Front Left Turn wire and Left Turn Indicator wire to the turn signal switch.

Terminal #19 Right Front Turn Signal: This terminal serves only as a junction point to connect the Front Right Turn wire and Right Turn Indicator wire to the turn signal switch.

Terminal #20 Hazard Flasher: This terminal is fuse protected by the “Hazard” fuse. Testing this terminal with a test light will show that it is constantly hot. Applying a real load to this terminal (such as front and rear turn signal lamps) should cause the flasher to trip and the lights will flash. LED turn signals, however, often do not pull enough current to trip mechanical flashers. If you have LED turn signals and they glow but do not flash, replace the mechanical flashers with electronic flashers (Part # WRM 30105). Terminal #20 serves as a junction point to connect your hazard light switch (commonly on steering column) to a battery-hot “Flashed” power source.

Terminal #21 Turn Signal Flasher: This terminal is fuse protected by the “Turn” fuse. Testing this terminal with a test light will show that it is only hot when the ignition switch is in the run or accessory positions. With the ignition switch in the run or accessory position, applying a real load to this terminal (such as front and rear turn signal lamps) should cause the flasher to trip and the lights will flash. LED turn signals, however, often do not pull enough current to trip mechanical flashers. If you have LED turn signals and they glow but do not flash, replace the mechanical flashers with electronic flashers (Part # WRM 30105). Terminal #21 serves as a junction point to connect your turn signal switch (commonly on steering column) to a key-on “Flashed” power source.

Terminal #22 Left Rear Turn Signal: This terminal serves only as a junction point to connect the Rear Left Turn wire to the turn signal switch.

Terminal #23 Right Rear Turn Signal: This terminal serves only as a junction point to connect the Rear Right Turn wire to the turn signal switch.

Terminal #24 Brake Switch: This terminal serves only as a junction point to connect the brake switch to the turn signal switch. Here’s how it works: Terminal #8 provides constant 12 Volt power to one side of the brake switch. When you step on the brakes, power flows through the brake switch to terminal #24. From terminal #24, power then flows up to the turn signal switch and back down to terminals #22 and #23. On most cars, the rear turn lights also serve as the brake lights.

Terminal #25 P. Seats: This terminal is fuse protected by the PS/PW fuse. This terminal is “Battery Hot.” Use this terminal to provide power to your power seats.

Terminal #26 Accessory: This terminal is fuse protected by the PS/PW fuse. This terminal is “Battery Hot.” Use this terminal to provide power for “Battery Hot” accessories such as cell phone charge ports or remote entry system.

Terminal #27 P. Windows: This terminal is fuse protected by the PS/PW fuse. This terminal is “Battery Hot.” Use this terminal to provide power to your power windows.

Terminal #28 Accessory: This terminal is fuse protected by the “Fuel Pump” fuse. This terminal is hot when the ignition switch is in the run and start positions. It is not hot when the ignition switch is in the accessory position. Use this terminal to provide key-on arming power to your cooling fan relay. When you use this terminal to arm your electric fan relay, you can listen to the radio with the key in the accessory position and your cooling fan will not drain your battery. . Just remember, this terminal is not hot when the key is in the accessory position and if you blow the fuse, you will lose arming power to your fuel pump relay.

Terminal #29 Fuel Pump: This terminal is fuse protected by the “Fuel Pump” fuse. This terminal is hot when the ignition switch is in the run and start positions. It is not hot when the ignition switch is in the accessory position. Use this terminal to provide key-on arming power to your fuel pump relay. Do not connect your fuel pump directly to this terminal. Our 30 AMP Fuel Pump Relay Kit is (part #WRM-20104) USE A RELAY.

Terminal #30 Accessory: Just like terminal #28, this terminal is fuse protected by the “Fuel Pump” fuse. This terminal is hot when the ignition switch is in the run and start positions. It is not hot when the ignition switch is in the accessory position. You may use this terminal to arm accessory relays or provide key-on power to other low-amperage accessories. Just remember, this terminal is not hot when the key is in the accessory position and if you blow the fuse, you will lose arming power to your fuel pump relay.

Terminal #31 Reverse Lights: This terminal is simply a junction point to connect the reverse light wire to the reverse light switch. The reverse light switch is often located on the steering column in cars that have column shift. On Mopars with automatic transmissions, the reverse light switch is located on the transmission. On some GM cars with floor shift automatic transmissions, the reverse light switch is located on the shifter inside of the console.

Terminal #32 Reverse Light Feed: This terminal is fuse protected by the “REV LTS” fuse and is Key-On hot. Here’s how it works: With the ignition switch in the run or start position, terminal #33 provides power to the reverse light switch. When the transmission is in reverse, power flows through the reverse light switch, back to terminal #31 and on to the reverse lights.

## **The Wires**

Wire #1: Red 8 Gauge connects Power Terminal on Power Panel to Alternator

Wire #2: Red 8 Gauge connects Power Terminal on Power Panel to Starter (Battery Terminal)

Wire #3: Light Green 12 Gauge connects dimmer switch to high beam headlights

Wire #4: Tan 12 Gauge connects dimmer switch to low beam headlights

Wire #5: Red 12 Gauge connects terminal #5 on Power Panel to headlight switch

Wire #6: Green 14 Gauge connects terminal #16 on Power Panel to 12 volt horn

Wire #7: Light Blue 12 Gauge connects headlight switch to dimmer switch

Wire #8: Blue 16 Gauge connects terminal #15 on Power Panel to wiper switch (most after-market systems) or wiper motor (most OEM applications)

Wire #9: Tan 16 Gauge connects terminal #29 on Power Panel to fuel pump relay. **DO NOT CONNECT DIRECTLY TO FUEL PUMP. USE A RELAY**

Wire #10: Purple 12 Gauge connects terminal #6 on Power Panel to starter solenoid

Wire #11: White 14 Gauge connects terminal #24 on Power Panel to third brake light (if applicable) If you are not using a third brake light, simply snip the yellow fork terminal that connects this wire with wire #15. Replace the yellow fork terminal with a blue fork terminal on wire #15 and discard wire #11.



Wire #12: Red 12 Gauge connects terminals #25 and #27 on Power Panel to electric seats and power windows. Wire #12 is 16' long and is meant to provide power to both accessories.

Wire #13: Green 12 Gauge connects terminal #3 on Power Panel to the positive side of ignition coil. On HEI ignition systems, this wire simply plugs into the distributor cap on the BATTERY terminal. On points-style ignition systems, this wire typically connects to a ballast resistor that reduces voltage to the positive side of the coil. This wire can also be used as the key-on hot wire for engine computers as well as MSD boxes etc.

Wire #14: Black 12 Gauge connects various accessories to ground. Use this wire to provide good grounds in fiberglass bodies

Wire #15: White 14 Gauge connects terminal #24 on Power Panel to brake light switch. If you are not using a third brake light, simply snip the yellow fork terminal that connects this wire with wire #11. Replace the yellow fork terminal with a blue fork terminal on wire #15 and discard wire #11.

Wire #16: White 14 Gauge connects terminal #8 on Power Panel to brake light switch.

Wire #17: Red 16 Gauge connects terminals #14 / #30 on the Power Panel to electric fan relay. This wire is used to "Arm" the fan relay with key-on power. On the Power Panel, we suggest connecting this wire to terminal #30. On Power Panel II, we recommend using terminal 14. (See notes on terminal #14 & terminal #30 in THE PANEL section) Our 70 AMP cooling fan relay is (part #WRM-20106). DO NOT CONNECT THIS WIRE DIRECTLY TO THE COOLING FAN. USE A RELAY.

Wire #18: Tan 16 Gauge connects headlight switch to park lights

Wire #19: Brown 16 Gauge connects headlight switch to tail lights

Wire #20: Light Green 16 Gauge connects terminal #31 on Power Panel to reverse lights

Wire #21: Pink 16 Gauge connects terminal #4 on Power Panel to instruments. This is the key-on power wire for all of your instruments.

Wire #22: Orange 16 Gauge connects terminal #1 on Power Panel to clock and courtesy lights. This is a battery-hot wire. (See courtesy light wiring diagram Page 19).

Wire #23: White 16 Gauge connects courtesy lights to door switches. This wire serves to ground the courtesy light(s) (See courtesy light wiring diagram Page 19).

Wire #24: Tan 16 Gauge connects fuel sender to fuel gauge

Wire #25: Grey 18 Gauge connects headlight switch to instrument lights

Wire #26: Light Blue 16 Gauge connects Terminal #18 on Power Panel to front left turn signal

Wire #27: Light Blue 16 Gauge connects Terminal #18 on Power Panel to left turn signal indicator light on dash

Wire #28: Blue 16 Gauge connects terminal #19 on Power Panel to front right turn signal

Wire # 29: Blue 16 Gauge connects terminal #19 on Power Panel to right turn indicator light on dash

Wire #30: Green 16 Gauge connects terminal #23 on Power Panel to rear right turn signal

Wire #31: Yellow 16 Gauge connects terminal #22 on Power Panel to rear left turn signal

Wire #32: Light Green 16 Gauge connects temperature sender in engine to temperature gauge

Wire #33: Blue 16 Gauge connects oil pressure sender in engine to oil pressure gauge

Wire #34: Black 18 Gauge connects instruments to ground

Wire #35: White 16 Gauge connects terminal #4 on Power Panel to alternator diode clip (See photos on page 20). If you are using a good one-wire alternator, this wire is optional. Most one-wire alternators do not begin to charge until the engine is revved a bit (typically 1200-1500 RPM). This wire, in conjunction with the diode clip that is included in the wire kit, provides voltage to the field windings of the alternator and allows it to charge at low engine rpm. Be sure to use this wire in conjunction with the supplied diode clip. A missing or faulty diode in this system will keep your engine from shutting off with the ignition key.

Wire #36: Light Green 16 Gauge connects dimmer switch to high beam indicator light on dash

Wire #37: Red 16 Gauge connects terminal #1 on Power Panel to radio 12 Volt Constant

Wire #38: Yellow 16 Gauge connects terminal #2 on Power Panel to radio 12 Volt Switched

Wire #39: Red 14 Gauge connects terminal #1 / #26 on Power Panel to cigarette lighter

Wire #40: Purple 16 Gauge connects terminal #13 to A/C relays / blower

Wire #41: Brown 16 Gauge connects negative side of ignition coil to tachometer. On HEI ignition systems, this wire connects the TACH terminal on the distributor cap to the tachometer.

Wire #42: Blue 16 Gauge connects terminal #14 / #28 to electric choke on carburetor

### **Steering Column Pigtail**

Wire #43: White 14 Gauge connects terminal #24 on Power Panel to steering column (Brake Light Feed)

Wire #44: Green 16 Gauge connects terminal #23 on Power Panel to steering column (Rear Right Turn)

Wire #45: Yellow 16 Gauge connects terminal #22 on Power Panel to steering column (Rear Left Turn)

Wire #46: Purple 16 Gauge connects terminal #21 on Power Panel to steering column (Turn Signal Feed)

Wire #47: Brown 16 Gauge connects terminal #20 on Power Panel to steering column (Hazard Feed)

Wire #48: Blue 16 Gauge Connects terminal #19 on Power Panel to steering column (Front Right Turn)

Wire #49: Lt Blue 16 Gauge connects terminal #18 on Power Panel to steering column (Front Left Turn)

Wire #50: Black 16 Gauge connects terminal #17 on Power Panel to steering column (Horn Button)

### **Ignition Pigtail**

Wire #51: Red 10 Gauge connects power terminal on Power Panel to ignition switch (BATT Terminal)

Wire #52: Pink 12 Gauge connects terminal #4 on Power Panel to ignition switch (IGN Terminal)

Wire #53: Purple 12 Gauge connects terminal #7 on Power Panel to ignition switch (Start Terminal)

Wire #54: Orange 12 Gauge connects terminal #12 on Power Panel to Ignition Switch (IGN Terminal)

Wire #55: Brown 12 Gauge connects terminal #11 on Power Panel to Ignition Switch (ACC Terminal)

### **Reverse Light Pigtail**

Wire #56: Pink 16 Gauge connects terminal #32 on Power Panel to reverse light switch

Wire #57: Light Green 16 Gauge connects terminal #31 on Power Panel to reverse light switch

### **Neutral Safety Switch Pigtail**

Wire #58: Purple 12 Gauge connects terminal #6 on Power Panel to Neutral Safety Switch

Wire #59: Purple 12 Gauge connects terminal #7 on Power Panel to Neutral Safety Switch

### **Optional Parts To Enhance Your Wiring Project**

- \*VIN-33137-VUI Large Gromet
- \*WRM-20102 Mopar Neutral Safety Relay
- \*WRM-30101 Lever Style Brake Switch (Can be used on clutch linkage for Neutral Safety)
- \*LOK-BL1400U GM Trans-Mounted Reverse Light/Neutral Safety Switch
- \*WRM-30100 Universal Ignition Switch
- \*WRM-20101 GM Key-On-Column Kit
- \*WRM-30103 GM Replacement Headlight Switch W/ Conector & Brass Terminals
- \*WRM-30104 Courtesy Light Door Switches
- \*WRM-30102 Universal Clamp On Turn Signal Switch
- \*WRM-20103 Universal Clamp-On Turn Signal Switch Pigtail
- \*WRM-20106 Electric Fan Relay Kit
- \*WRM-30106 Optional 180/160 Block Sender For Fan Relay Kit
- \*WRM-20105 Toggle Switch Turn Signal Kit
- \*WRM-20104 Fuel Pump Relay Kit
- \*WRM-30105 Electronic LED Flasher Kit

If you have questions or need to order optional parts while installing your wiring kit please feel free to give us a call. We are happy to help. 620-792-2836

# Courtesy Light Wiring Diagram

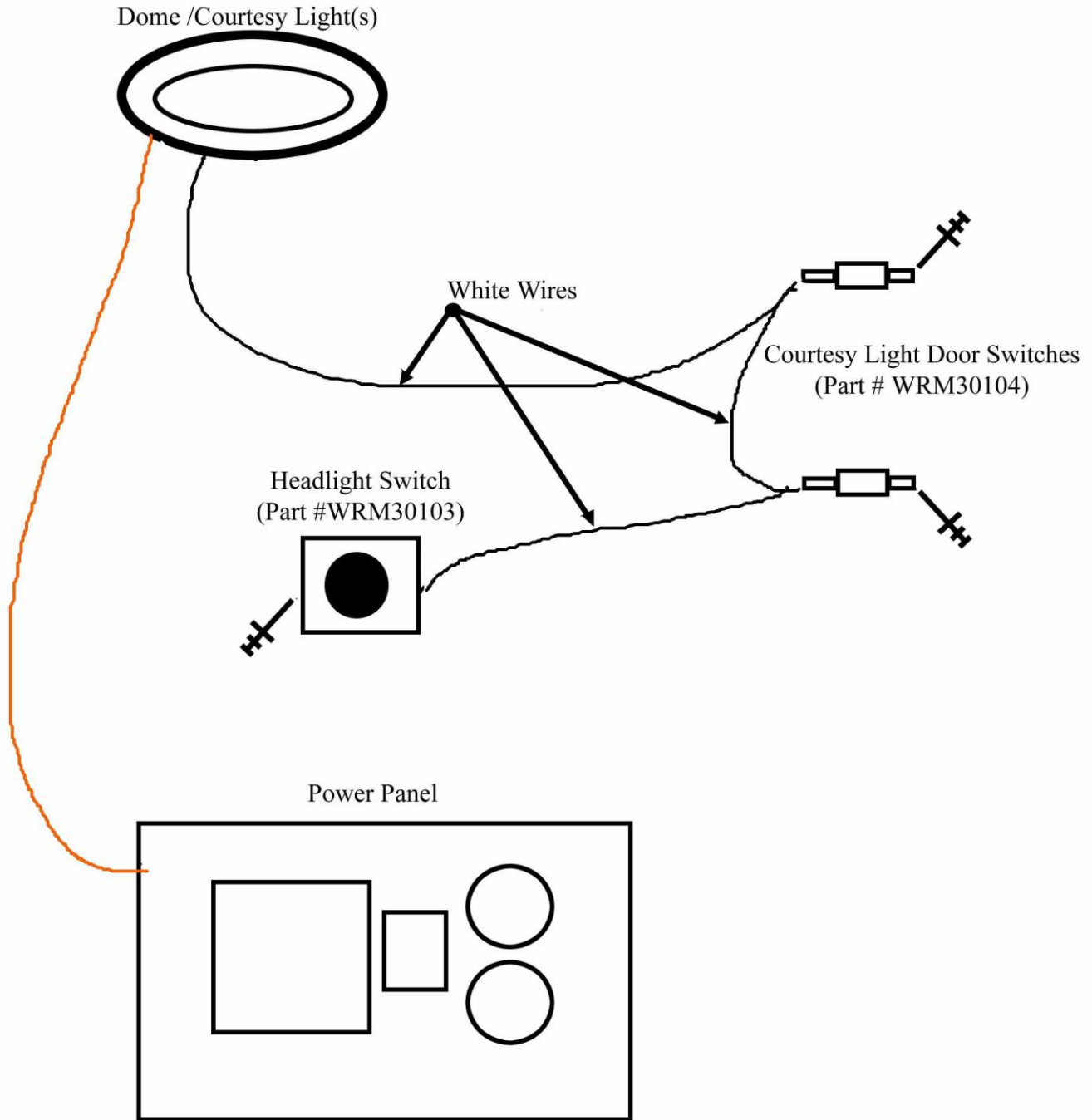

Courtesy lights are wired to be hot all of the time. The courtesy light door switches (Part#WRM30104) create a ground for the light(s) when the door(s) are opened. The headlight switch (Part #WRM30103) also creates a ground for the light(s) when the knob is rotated fully counter clockwise .

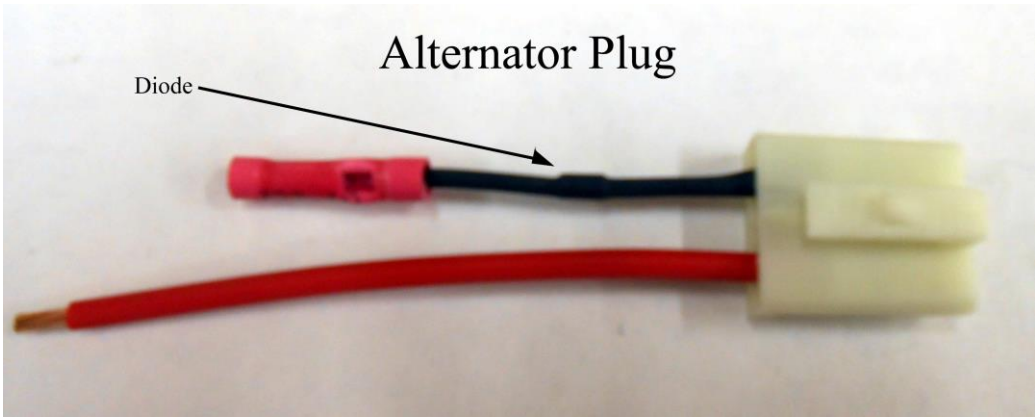

Remove rubber plug from one-wire alternator and snap alternator plug into place.

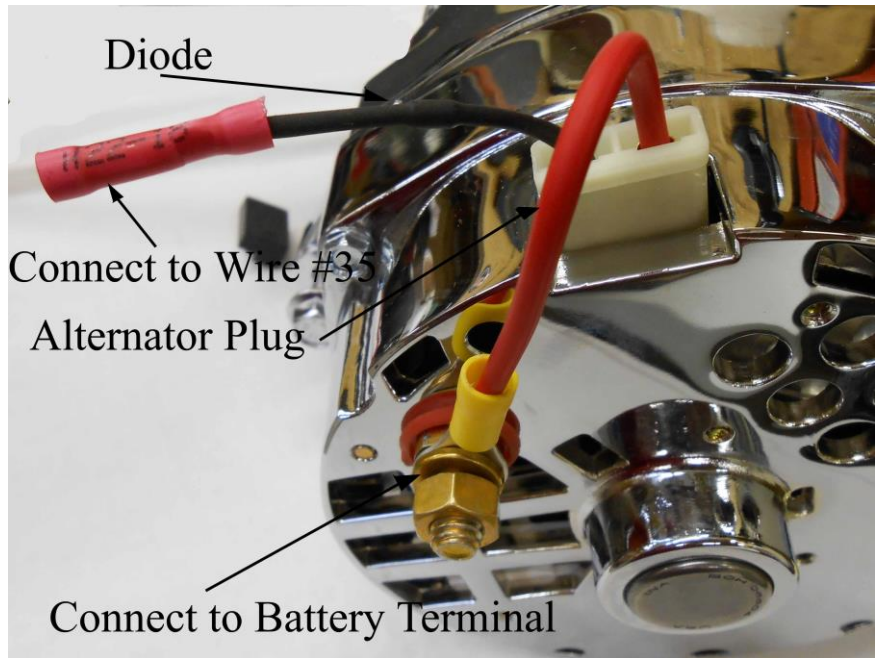

# Mounting Template

Top

