

Power Cowl Vent Unit Assembly

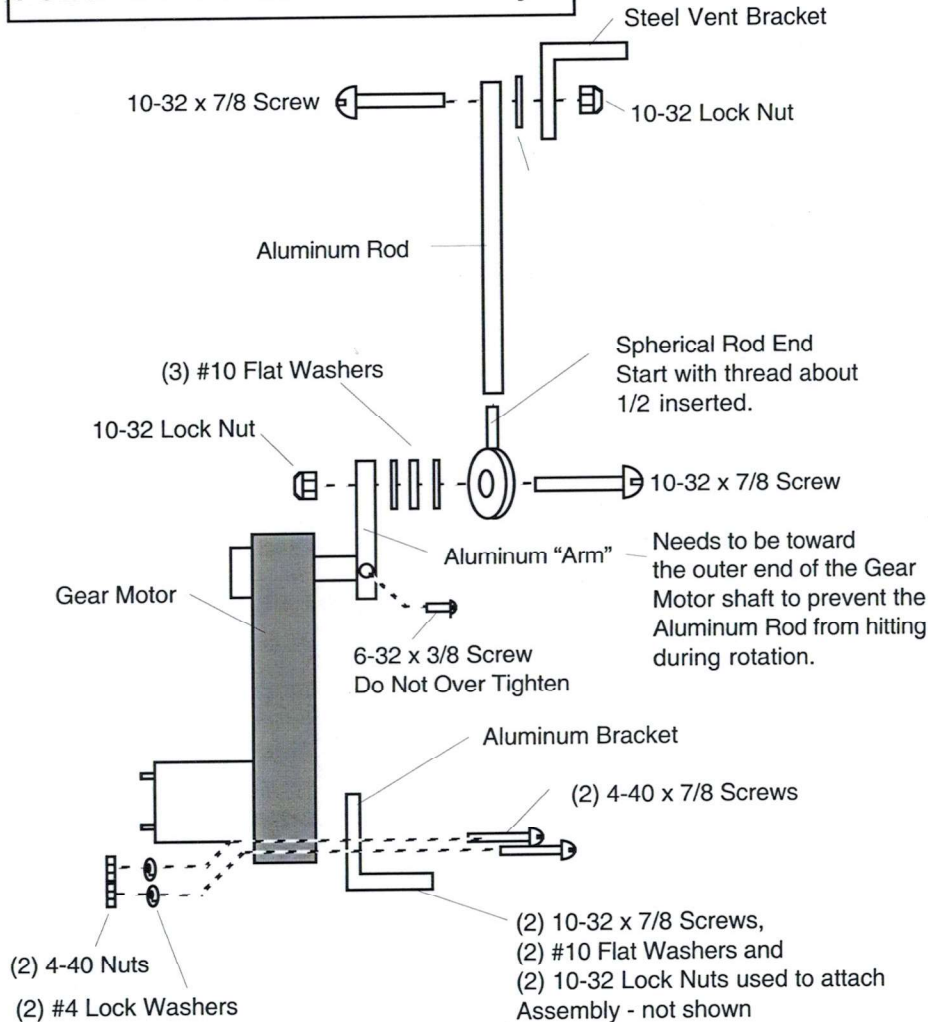

POWER COWL VENT KIT

#L34

Powerful electric gear motor drive for opening and closing cowl vents, glove boxes, etc. Bolt-on motor/gear box, bolt-on or weld-on cowl bracket.

Motor is not waterproof.

Kit Includes:

- Motor and gear drive with 10 pounds of push/pull
- Mounting brackets and mounting hardware
- Wiring, push button and installation instructions.

Manufactured by Watson's StreetWorks Rod & Custom Products

Thank you for buying a StreetWorks product. Be confident that it will provide the quality and performance that you demand for your car. Please read and understand all installation instructions before beginning. Planning and preparation will make the entire process easy and quick. **DISCONNECT POWER AT THE BATTERY BEFORE DOING ANY WIRING!**

1. Make sure that your vent moves smoothly and easily.
2. Assemble the unit as shown at left.
3. Determine the best location for the motor and how you will attach the unit to your cowl vent. This is best done with the vent in the closed position. **See the diagrams and notes.** The vent bracket provided (small steel bracket) may be welded-on, drilled and bolted, or (for vents that have a center "rib" our bracket) may be discarded and the rod attached directly to the rib. When attached to the rib, be sure that the rib is sufficiently strong to take repeated operation.
4. The motor/gear box unit is a bolt-on that can be attached to the firewall or to a bracket (not provided) off the firewall and/or dash. **IMPORTANT:** Allow yourself some adjustment to the location so that the vent will fully close at the "bottom" of the motor arm travel without binding the motor. Correctly set-up, the motor will run freely except when the vent is in the closed position when a slight decrease in motor speed should be heard. For best alignment and operation the center of rotation of the motor arm should be directly below where the unit is attached to the vent. **See "Typical Installation"**. To check the operation, temporarily connect 12 vdc ("+" to the red wire and "-" to the green wire) and run the unit through full cycles. Lightly grease the rod end pivots after final installation.

Watson's
StreetWorks

4 Bud Way, Suite 3, Nashua, NH
866.859.0513

Tech@watsons-streetworks.com

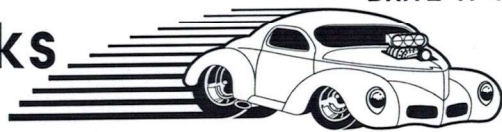

This entire document © StreetWorks LLC, 2012

Typical Installation viewed from side

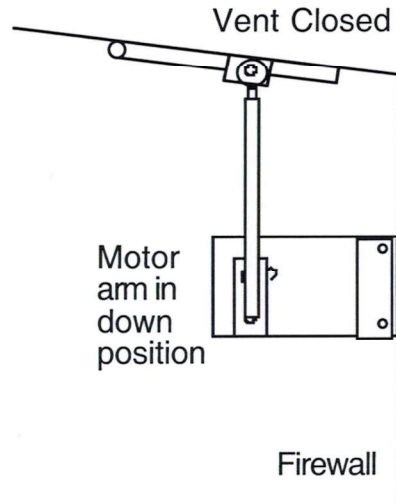

* NOTE: The full open angle of the vent will depend upon how close the rod attachment is to the vent door hinge ("d"). Our unit has a two inch lift, so if "d" = 2 inches the open angle will be 45 degrees (our recommended position). If "d" is greater than 2 inches the open angle will be less than 45 degrees. And if "d" is less than 2 inches the open angle will be greater than 45 degrees and MAY CAUSE BINDING.

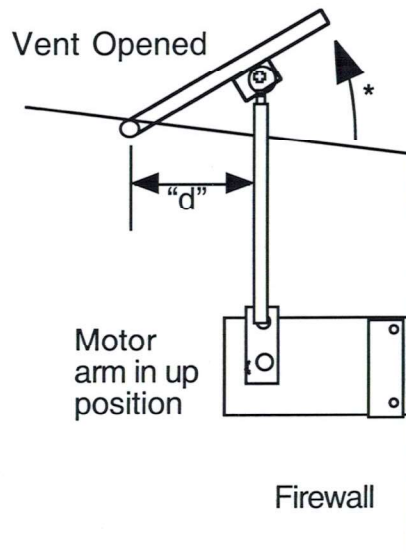

5. To wire, connect the red wire to +12 vdc fused 2 amps maximum and ground the green wire to a good chassis ground. If you want to reverse the rotation of the motor unit, CAREFULLY remove and reverse the wire terminals at the motor.

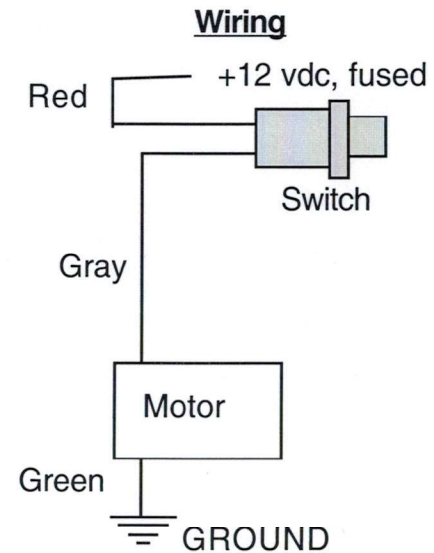

Watson's StreetWorks has an extensive line of street rod and custom car and truck parts with one of the largest selections of billet interior trim and electrical accessories. Check us out on the web at www.watsons-streetworks.com.