

A.C. COMPRESSOR MOUNT 142R

GM LS Series Truck Motor Low Mount

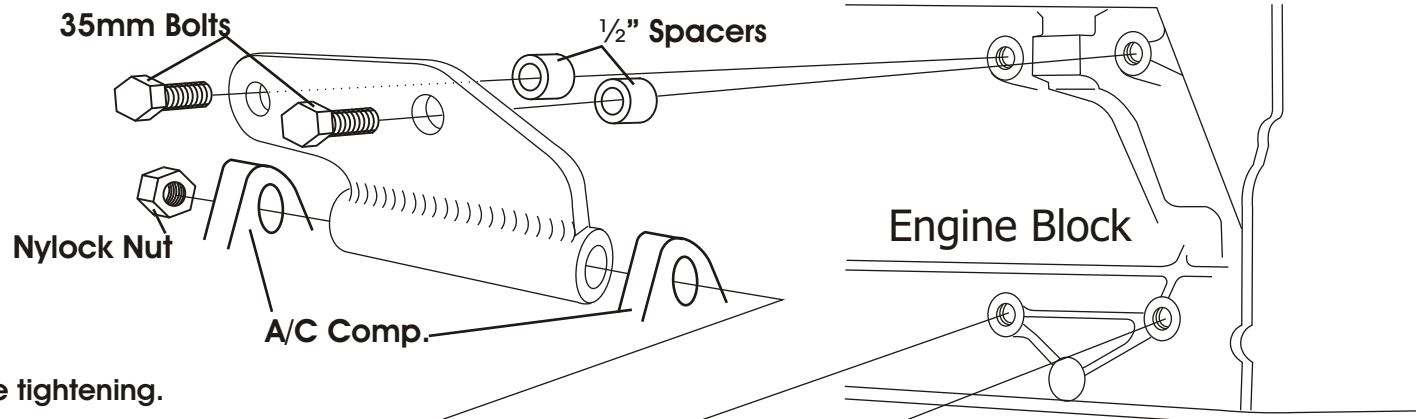

***Note:** Be sure to start all bolts before tightening.

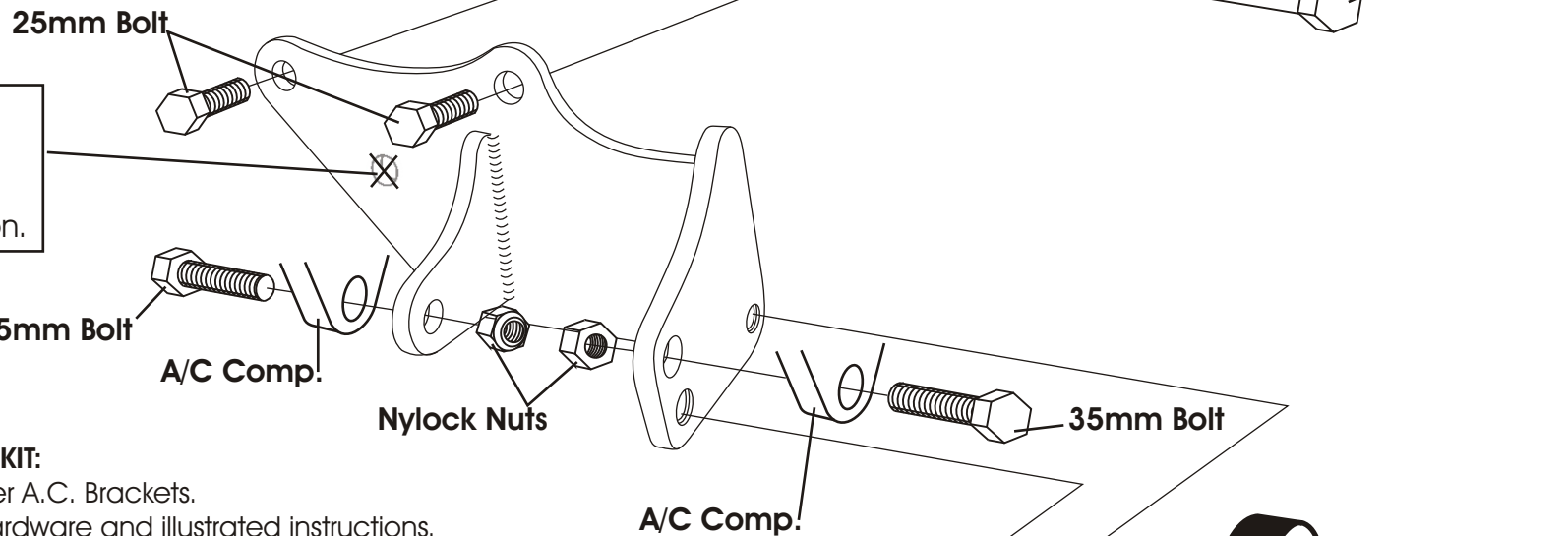

***Note:** This hole is for the LS1 Aluminum block and will not be used in this application.

PARTS INCLUDED IN THIS KIT:

- Upper and Lower A.C. Brackets.
- All necessary hardware and illustrated instructions.
- Heavy duty automatic belt tensioner.
- 38" Four rib belt (Dayco# 5040373)

***Compressor and belt information:** This bracket is designed for the Sanden 508 A.C. Compressor (Sanden Part# 4514). Sanden Compressors are equipped with a 7 groove clutch pulley; **only the front 4 grooves will be used in this application.**

This bracket system is designed for Gen III GM LS series Truck Motors. AS WITH ANY PART OF THIS NATURE, MAKE SURE IT FITS YOUR APPLICATION BEFORE PAINTING OR PLATING. PARTS THAT HAVE BEEN PAINTED, PLATED OR MODIFIED MAY NOT BE RETURNED.

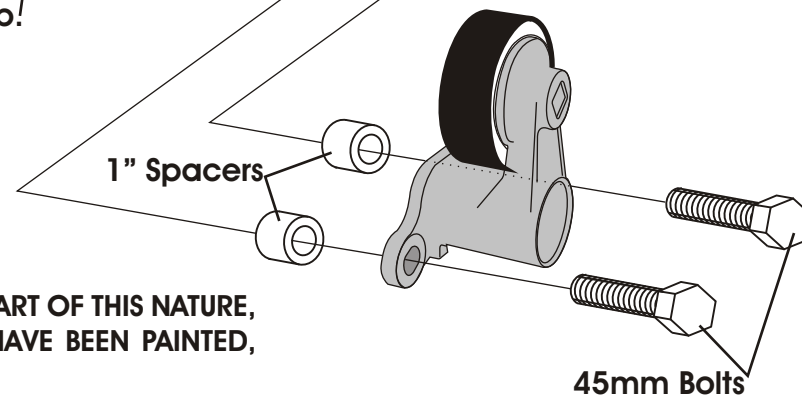

A.C.
COMPRESSOR
MOUNT
142R

GM LS Series Truck Motor Low Mount
Passenger Side

ALAN GROVE COMPONENTS, INC.
27070 METCALF ROAD
LOUISBURG, KS 66053