

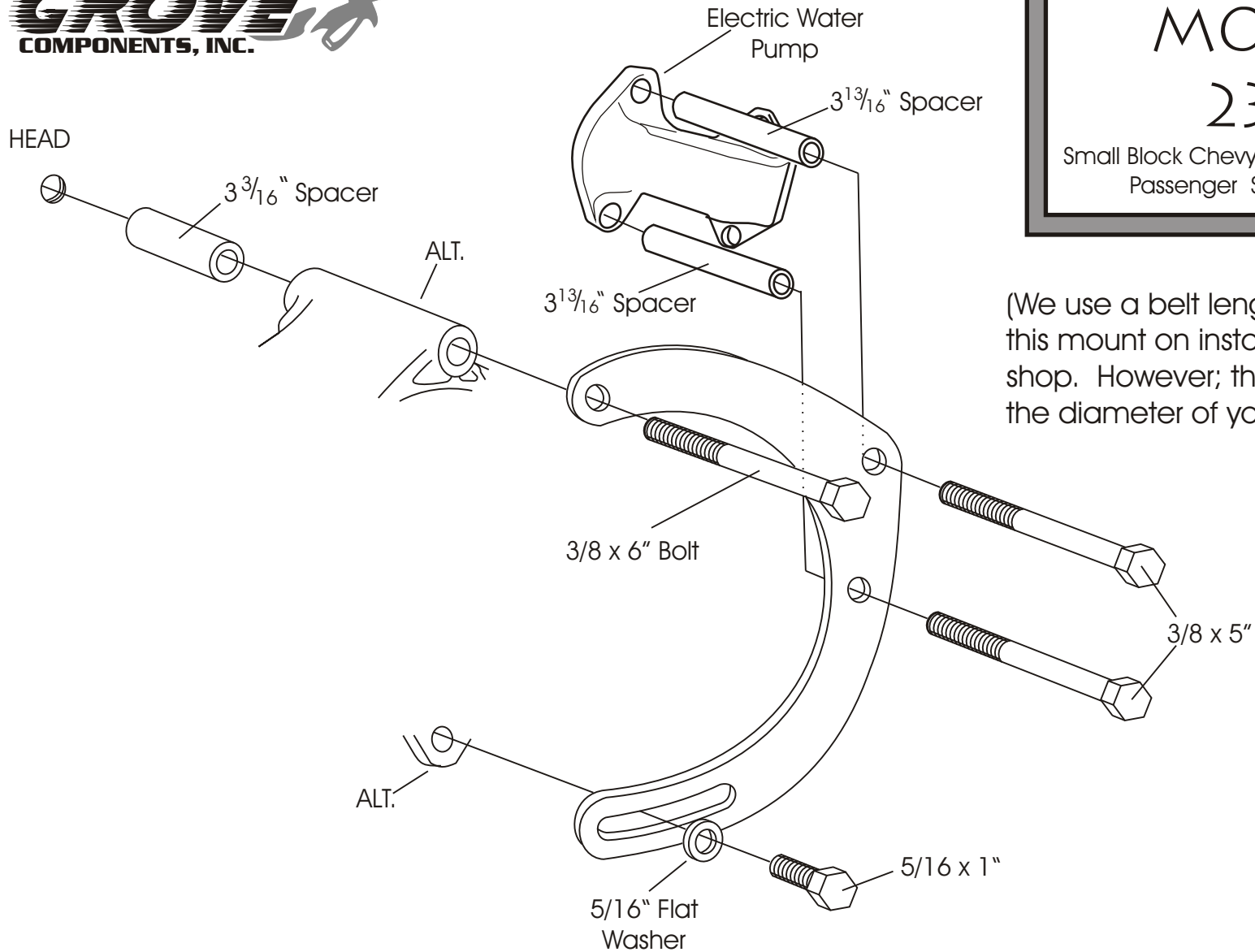

ALTERNATOR MOUNT 235R

Small Block Chevy - Electric Water Pump
Passenger Side - Mid-Mount



(We use a belt length of 39" with this mount on installations in our shop. However; this can vary with the diameter of your pulleys.)

As with any part of this nature, make sure it fits your application before painting or plating. Parts that have been painted, plated or modified may not be returned.

ALTERNATOR
MOUNT
235R

Small Block Chevy - Electric Water Pump
Passenger Side - Mid-Mount

ALAN GROVE COMPONENTS, INC.
27070 METCALF ROAD
LOUISBURG, KS 66053