

R



Ice Cream Maker

USER CARE AND INSTRUCTION MANUAL

Thank you for purchasing the **RICARDO** ice cream maker. Before using this product, please read the user care and instruction manual carefully.

IMPORTANT SAFEGUARDS

.....

When using electrical appliances, basic safety precautions should always be followed to prevent fire, electric shock, serious personal injury and/or property damage, including the following.

READ ALL INSTRUCTIONS CAREFULLY BEFORE FIRST USE.

- ::: This appliance should not be used by children. Keep appliance and its cord out of the reach of children and pets. Close adult supervision is necessary when any appliance is used near children.
- ::: Keep this appliance and the packing material out of the reach of children.
- ::: Keep hair and clothing away from the revolving mixing paddle.
- ::: Never reach into the mixing paddle while it is in motion. Kitchen utensils must not come into contact with the revolving mixing paddle.
- ::: To avoid frostbite, handle the chilled insulated bowl with pot holders or oven mitts.
- ::: Do not use the appliance if the appliance itself or the main cord shows visible signs of damage or if the appliance has been dropped.
- ::: Do not make any modifications to the appliance, nor replace the main cord yourself. Only have repairs carried out by a certified specialist. Improper repairs can result in considerable danger to the user.
- ::: Only connect the appliance to a properly installed wall outlet with the same main voltage rating as identified on the machine.
- ::: Always pull on the plug, not the cord.
- ::: Remove the plug from wall outlet: in the event of a technical fault, when the appliance is not in use, before assembling or disassembling and before cleaning.
- ::: The wall outlet used must be within easy reach so that the main plug can be removed quickly if necessary. Route the main cord so that it cannot be tripped over.
- ::: The main cord must not be tangled or squeezed. Keep the main cord away from hot surfaces and sharp edges.
- ::: Do not leave the appliance unattended.
- ::: This appliance must not be used with a timer or remote controlled system.
- ::: The power unit, main cord and main plug must never be immersed in water or other liquids. Protect the appliance from moisture, humidity and water.
- ::: Only use indoors. Do not position in the immediate vicinity of moist areas, such as sinks.
- ::: The ice cream maker may no longer be used and must be disposed of if any coolant leaks from the insulated bowl. The coolant is not poisonous, but should not be consumed.
- ::: Always use the ice cream maker on a stable, level and dry surface.
- ::: Keep the ice cream maker away from sources of heat.

- ::: The mixing paddle automatically changes its direction of rotation when the ice cream mixture has become very thick. This is a protective function to prevent the motor from overheating. If the direction keeps switching, turn the appliance off.
- ::: The motor will automatically shut off if it overheats. In this case, remove the main plug from the wall outlet and allow the power unit to cool off for at least 15 minutes.
- ::: Never leave the ice cream maker unattended. Churning time can vary depending on the quantity, ingredients (e.g. alcohol) and desired consistency. The mixture can become very thick causing the mixing paddle to jam. In this case, turn off the appliance immediately.
- ::: Do not turn the ice cream maker on and off while the ice cream is churning, otherwise the mixture will stick to the insulated bowl and block the mixing paddle.
- ::: Only use the ice cream maker with the original accessories provided.
- ::: Only the mixing paddle, the lid (without the power unit), the connector piece and the base may be cleaned in the dishwasher. Clean the power unit and the insulated bowl by hand.

IMPORTANT SAFEGUARDS FOR THE INSULATED BOWL

- ::: The insulated bowl must be completely dry before it is placed in the freezer:
 - ... Place the insulated bowl in a freezer bag to prevent freezer odor in the bowl.
 - ... Place the freezer bowl upright and in a level position in the freezer (never upside-down).
- ::: If you keep the insulated bowl in your freezer after each use, you can make ice cream anytime!
- ::: Do not use any hard or pointed objects (e.g. metal spoons) to remove the ice cream, as these can damage the inner surface of the insulated bowl. Always use wooden or silicone kitchen utensils to remove the ice cream.
- ::: Do not damage the freezer bowl by puncturing it or by heating it to over 40 °C.
- ::: Before cleaning, allow the freezer bowl to thaw completely, until it has reached room temperature.
- ::: Do not use abrasive or corrosive detergents or hard brushes for cleaning.
- ::: Do not put the insulated bowl in dishwasher or submerge in any liquid.

NOTES ON THE PLUG

As a safety feature, the appliance is equipped with a polarized plug (one blade is wider than the other). To reduce the risk of electric shock, this plug can only be inserted one way into the electrical outlet. If the plug does not fit correctly into the outlet, reverse the plug and insert into the outlet. If it still does not fit, contact a qualified electrician for further assistance. Do not attempt to modify the plug in any way.

NOTES ON THE CORD

The short power-supply cord provided should be used to reduce the risk resulting from becoming entangled in or tripping over a longer cord. Do not use an extension cord with this appliance.

DO NOT OPERATE APPLIANCE IF THE CORD SHOWS ANY DAMAGE OR IF APPLIANCE WORKS INTERMITTENTLY OR STOPS WORKING ENTIRELY.

ELECTRIC POWER

If the electrical circuit is overloaded with other appliances, the appliance may not operate properly. It should be plugged into a separate electrical circuit.

TECHNICAL DATA

Main voltage: 120V / Frequency: 60Hz / Power consumption: 15 watts

PARTS IDENTIFICATION

Product may vary slightly from diagram.

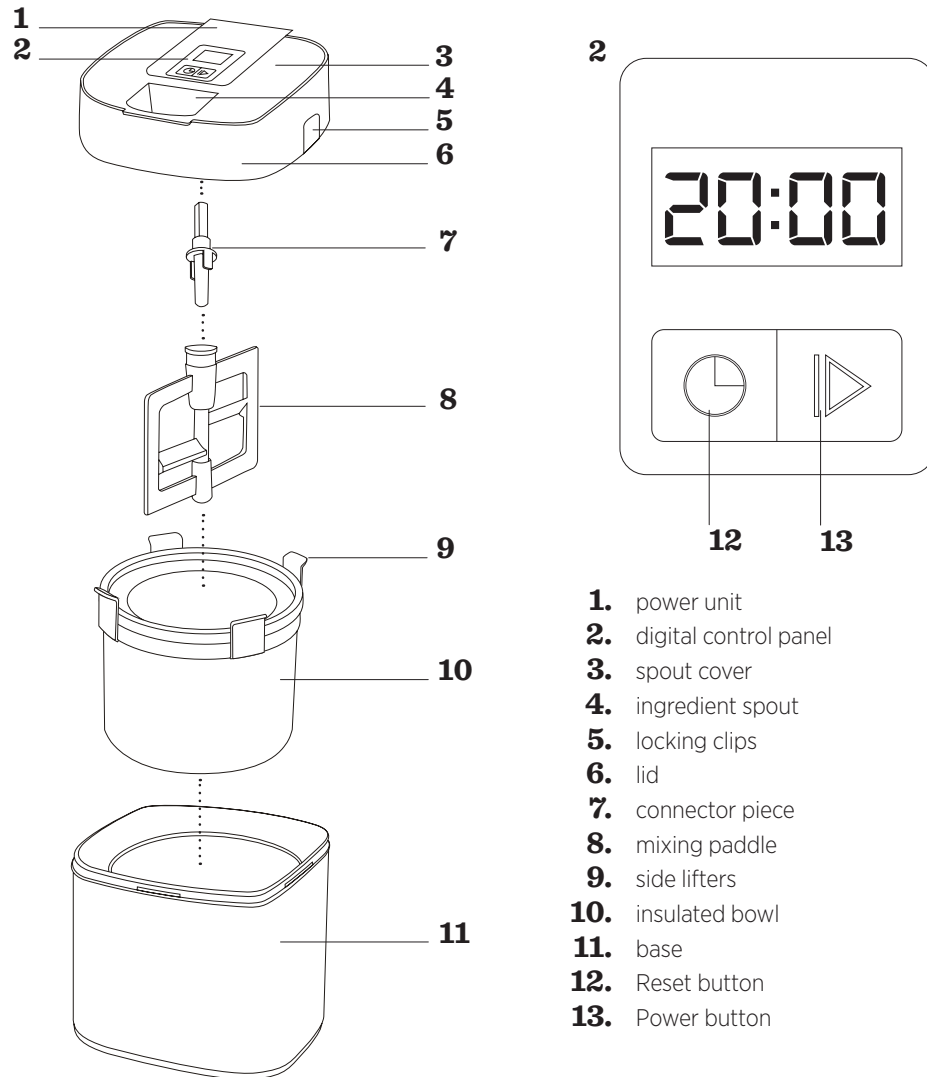

1. power unit
2. digital control panel
3. spout cover
4. ingredient spout
5. locking clips
6. lid
7. connector piece
8. mixing paddle
9. side lifters
10. insulated bowl
11. base
12. Reset button
13. Power button

BEFORE FIRST USE

∴ Clean thoroughly before using the ice cream maker for the first time.

∴ Disassemble the ice cream maker to clean it.

HOW TO DISASSEMBLE

1- Unplug the machine if it is plugged in.

2- Remove the lid by pressing the two locking clips on each side of the lid.

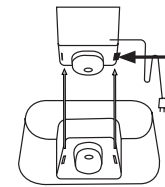

3- Press the release levers on the sides of the power unit, lift and remove the power unit from the lid

4- Separate the mixing paddle from the connector piece. When using the machine for the first time, the mixing paddle will be found inside the insulated bowl.

5- Remove the connector piece from the power unit.

6- Remove the insulated bowl from the base by using side lifters.

CLEANING

IMPORTANT!

∴ The power unit and insulated bowl must never be immersed in water or other liquids.

∴ After use, always wait until the insulated bowl has reached room temperature before cleaning it.

1- Unplug the machine if it is plugged in.

2- Use a soft, damp cloth to clean the power unit.

3- Thoroughly wash the base, lid, mixing paddle and connecting piece in hot soapy water. Then rinse clean with hot water.

4- Thoroughly clean the inside of the insulated bowl using hot (up to 40°C) soapy water and a damp cloth.

5- Dry all parts completely.

HOW TO ASSEMBLE

1- Place the insulated bowl inside the base.

2- Place the power unit onto the lid and press down firmly. You should feel and hear the power unit click and lock into place.

3- Insert the connector piece into the power unit and attach the mixing paddle to the connector piece.

4- Place the lid (with power unit attached) on top of the base until it locks into place.

MAKING ICE CREAM

IMPORTANT!

::: The insulated bowl must be placed in the freezer at -18 °C for a **minimum of 8 hours** beforehand, each time you prepare ice cream.

::: Prepare the ice cream mixture at least 4 hours beforehand and refrigerate.

::: Only remove the insulated bowl out of the freezer immediately before making ice cream. Assemble the ice cream maker quickly to avoid thawing of the insulated bowl.

1- Plug machine into an easily accessible wall outlet 120V AC, a beep will be heard.

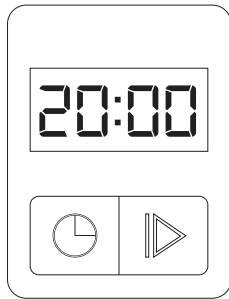

2- The default running time of the machine is 20 minutes. To increase the running time on the timer, press the Reset button , a beep will be heard. Each press will increase the running timer by 1 minute. The maximum running time is 40 minutes.

3- Once the running time is set, press the Power button  to start the machine. The digital control panel will display the remaining churning time.

4- Open the spout cover to pour the prepared and well-chilled ice cream mixture into the ingredient spout as the machine is churning. When adding ingredients into the insulated bowl, ensure at least 5 cm between the top of the mixture and the rim of the bowl. The mixture will expand as it churns, requiring more space.

5- For the last 10 seconds of the remaining time, a beep will be heard at each second until the timer is up. The machine will automatically shut off once the time is completed. To shut off the machine before the remaining time is completed, press on the Power button .

6- Remove the lid and use a wooden or silicone utensil to remove the ice cream.

HELPFUL TIPS

::: You will get particularly good results if the insulated bowl and the prepared ice cream mixture are completely chilled. This also shortens churning time.

::: If, after 40 minutes the ice cream mixture still isn't firm enough, place in the freezer until it has sufficiently set. Note: with time, homemade ice cream can set harder than shop-bought ice cream.

::: Alcohol slows down the cooling process of the ice cream mixture.

STORAGE

Ensure all pieces are clean and dry before storing. Store machine in its box or in a dry, clean place.

2-YEAR LIMITED WARRANTY (Applies only in Canada)

This warranty covers any defects in materials and workmanship for a period of two (2) years from the date of the original purchase. Please retain your original receipt as a proof of the purchase date. Any complaints must be registered within the warranty period. The product will be repaired, replaced (parts or entire appliance) or refunded at our sole discretion. Shipping charges may apply.

This warranty does not cover normal wear of parts or damage resulting from any of the following: negligent use or misuse of the product including failure to clean the product regularly, use for commercial purposes, accident, use on improper voltage or current, use contrary to the operating instructions, disassembly, repair or alteration by anyone other than a **RICARDO** authorized service agent.

Please do not return this product to the store. For assistance, please contact 1-833-751-4101.

If you have any questions regarding this product, please contact our customer service:

::: by e-mail: customerservice@ricardocuisine.com

::: by phone: 1-833-751-4101



vanilla ice cream

PREPARATION 15 minutes
COOKING 15 minutes
COOLING 4 hours
FREEZING 1 hour
MAKES 4 cups (1 litre)

3/4 cup (160 g) sugar
1 tbsp (15 ml) cornstarch
4 egg yolks
1/2 vanilla bean, split lengthwise and seeds scraped
1 1/2 cups (375 ml) 35% heavy cream, warm
1 1/2 cups (375 ml) milk, warm

- 1** In a saucepan off the heat, combine the sugar and cornstarch. Whisk in the egg yolks, vanilla seeds and pod until smooth. Whisk in the cream and milk.
- 2** Cook over medium heat, stirring constantly with a wooden spoon, scraping the sides and bottom of the pan, until the mixture begins to simmer, thicken and coat the back of the spoon, about 15 minutes. Transfer to a bowl, cover with plastic wrap directly on the surface of the ice cream base and let cool. Refrigerate for 4 hours. If desired, place the bowl over an ice bath for faster chilling. Strain the ice cream base.
- 3** Pour the chilled ice cream base into the ice cream maker and churn for 20 minutes or until thickened.
- 4** Transfer to an airtight container and freeze for 1 hour or until ready to serve. Let the ice cream sit at room temperature for several minutes before serving, if needed.

| NOTE | It is very important that the mixture is completely chilled before churning.
 The mixture can be refrigerated up to 4 days before churning.



chocolate ice cream

PREPARATION 15 minutes
COOKING 15 minutes
COOLING 4 hours
FREEZING 1 hour
MAKES 4 cups (1 litre)

3/4 cup (160 g) sugar
1 tsp (5 ml) cornstarch
4 egg yolks
1 1/2 cups (375 ml) 35% heavy cream, warm
1 1/2 cups (375 ml) milk, warm
4 oz (115 g) dark chocolate, chopped

- 1** In a saucepan off the heat, combine the sugar and cornstarch. Whisk in the egg yolks until smooth. Whisk in the cream and milk.
- 2** Cook over medium heat, stirring constantly with a wooden spoon, scraping the sides and bottom of the pan, until the mixture begins to simmer, thicken and coat the back of the spoon, about 15 minutes. Remove from the heat.
- 3** Add the chocolate. Stir until the chocolate has melted and the ice cream base is smooth. Strain into a bowl. Cover with plastic wrap directly on the surface of the ice cream base and let cool. Refrigerate for 4 hours. If desired, place the bowl over an ice bath for faster chilling.
- 4** Pour the chilled ice cream base into the ice cream maker and churn for 30 minutes or until thickened.
- 5** Transfer to an airtight container and freeze for 1 hour or until ready to serve. Let the ice cream sit at room temperature for several minutes before serving, if needed.

| NOTE | It is very important that the mixture is completely chilled before churning.
 The mixture can be refrigerated up to 4 days before churning.



raspberry sorbet

PREPARATION 15 minutes
FREEZING 5 hours
MAKES 4 cups (1 litre)

3 cups (750 ml) seedless raspberry puree, cold
1 cup (210 g) sugar
2 tbsp (30 ml) corn syrup
1 tbsp (15 ml) lemon juice

- 1** In a bowl, combine all the ingredients until the sugar has dissolved.
- 2** Pour the sorbet base into the ice cream maker and churn for 20 minutes or until thickened.
- 3** Transfer to an airtight container and freeze for 5 hours or until ready to serve. Let the sorbet sit at room temperature for several minutes before serving, if needed.



mango sorbet

PREPARATION 15 minutes
FREEZING 5 hours
MAKES 4 cups (1 litre)

3 cups (750 ml) mango puree, cold
1 cup (210 g) sugar
2 tbsp (30 ml) corn syrup
1 tbsp (15 ml) lemon juice

- 1** In a bowl, combine all the ingredients until the sugar has dissolved.
- 2** Pour the sorbet base into the ice cream maker and churn for 20 minutes or until thickened.
- 3** Transfer to an airtight container and freeze for 5 hours or until ready to serve. Let the sorbet sit at room temperature for several minutes before serving, if needed.



vanilla frozen yogurt

PREPARATION 10 minutes

FREEZING 5 hours

MAKES 4 cups (1 litre)

- 3 cups** (750 ml) 5% Greek yogurt, cold
- 1/2 cup** (105 g) sugar
- 1/4 cup** (60 ml) corn syrup
- 1** vanilla bean, scraped seeds only

- 1** In a blender, purée all the ingredients until smooth.
- 2** Pour the frozen yogurt base into the ice cream maker and churn for 20 minutes or until thickened.
- 3** Transfer to an airtight container and freeze for 5 hours. Let the frozen yogurt sit at room temperature for several minutes before serving, if needed.



lemon slushies

PREPARATION 15 minutes

COOKING 4 minutes

COOLING 4 hours

MAKES 4 cups (1 litre)

- 1** lemon
- 3 cups** (750 ml) water
- 1 cup** (210 g) sugar
- 1 cup** (250 ml) lemon juice

- 1** On a work surface, remove the zest from half of the lemon using a vegetable peeler. Finely chop the zest.
- 2** In a saucepan, bring 1 cup (250 ml) of the water, the sugar and chopped lemon zest to a boil, stirring until the sugar dissolves. Transfer to a large bowl. Add the remaining water and the lemon juice. Cover and refrigerate for 4 hours.
- 3** Pour the chilled lemon syrup into the ice cream maker and churn for 20 minutes or until thickened and slushy.
- 4** Serve in glasses with wide straws. Keep the slushie mixture cool in the ice cream maker for up to 1 hour.

