

# VICAIR<sup>®</sup>

LIFETIME  
WARRANTY



 **dynamic**  
HEALTH CARE SOLUTIONS

relief by air



**LIFETIME WARRANTY** is a unique Vicair service that applies to the latest generation of Vicair SmartCells.

We stand for the quality of these cells and therefore will always replace them in case some of them unexpectedly do not last a lifetime. Vicair Lifetime Warranty is an off-the-shelf service, no registration necessary. You can recognize the new generation SmartCells by their new black Vicair logo-print.

relief by air



# VICAIR TECHNOLOGY



**The best medium for pressure redistribution is air. Unfortunately, there are a few drawbacks; air is unstable and it tends to leak. Vicair solved these issues when they created Vicair SmartCells.**

The unique Vicair Air-Technology, which uses the small air-filled SmartCells, was developed in cooperation with the Amsterdam Rehabilitation Centre. It was awarded the **Grand Prix at the 'Salon des Inventions'** in Geneva, Switzerland. Vicair develops and produces its product line in the Netherlands for customers all over the world.

## **Lifetime Warranty**

*The latest generation Vicair SmartCells - printed with the black logo - come with lifetime warranty.*

**Unique combination of skin protection and positioning.** When you sit on a Vicair wheelchair cushion, you are supported by hundreds of SmartCells. The layers of cells inside the cushion compartments move with so little friction that the effect resembles the behavior of a viscous fluid, slowly adjusting to the shape of your body. Also, because SmartCells deform individually, they conform to your body's contours. The result is superior pressure redistribution.



The design of the cushion compartments combined with the specific number of cells in the compartments make the Vicair cushion ultra stable and helps prevent the person sitting on it from sliding forward.

As a result the cushion reduces shear forces to a bare minimum and helps to create and maintain an optimal, functional posture.



## **Ready for use**

*The Vicair cushion is ready for use straight out of the box.*

**Ease of use.** Vicair SmartCell cushions are extremely user-friendly. The well balanced filling grade ensures that Vicair cushions are ready to use, but if you prefer, you can adjust the cushions to your personal positioning needs by adding or removing SmartCells.

## **Machine washable**

*You can easily machine wash the new Vicair O2 wheelchair cushions at 60°C.*

The cushion requires hardly any maintenance; there is no need for a pump or any other accessories, and once the cushion is set up, it doesn't require daily monitoring. Not only are the Vicair wheelchair cushions extremely comfortable, but they are incredibly lightweight – on average weighing less than 0.8 kg each. This makes them the lightest high performance wheelchair cushions available by far.

# AVAILABLE COVERS

A cushion cover has influence on the performance of a wheelchair cushion. Therefore the Vicair covers are made of high quality materials that enhance the performance of the Vicair cushion. Ensuring that you will experience maximum protection and comfort.

## Reversible Cover

The reversible cover protects the inner cushion, preventing moisture running through the cover onto the cushion. The cover is reversible; one side is a cool breathable fabric, and the other a wipeable fluid proof fabric. Both sides will protect the inner cushion and is ideal for institutional and home use where incontinence and hygiene is an issue.

## Air Exchange Cover

Specifically designed for the Vicair O2 series. This cover—similar to a cap—has a breathable outer layer and covers only the top part of the cushion. Leaving the bottom part open, allowing the cushion to continue to breathe and offering optimal ventilation and comfort. The cover is ideal to help manage one of the main causes of pressure sores.

# CUSHION SIZE

It's not only the unique technology of the Vicair cushions that provides an optimal seating position. Next to the seat cushion, a proper set up of the wheelchair is extremely important.

Think of the adjustment of the foot plate, correct seating angle, right backrest height, but also the seat to floor height.

To get the correct size of wheelchair cushion, Vicair recommends to measure as follows:

The width (X) of the cushion and the wheelchair seat should match. When the cushion rests against armrests or side-guards, the width of a Vicair seat cushion may be up to 2.5 cm (1") wider.\* The depth (Y) of the cushion and seat should match.

\* Exception: The width of the Vicair Active should match the width of the wheelchair seat.

## GENERAL TECHNICAL SPECIFICATIONS

Used materials	Latex free
Machine washable	60°C

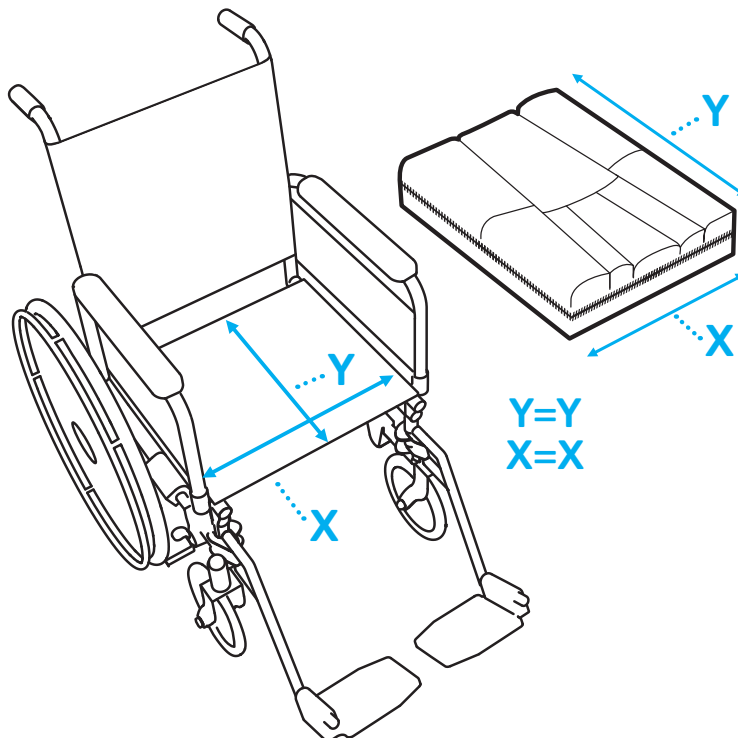

# VICAIR® VECTOR O2

## PRESSURE DISTRIBUTION + POSITIONING + STABILITY

**Ischial Well – Two compartments** for superior pressure reduction in the IT-coccyx area and extra positioning possibilities

**Trochanter support.** Firmer density to provide lateral stability and to redistribute pressure to help create an ischial well.



**Front compartments** provide leg alignment and stability. | Easily adjustable for individual positioning needs.

**Mid height zip closure** for easy adjustment when client is seated | Cushion keeps its shape, enhancing the user's skin protection



**MACHINE WASHABLE**

**100% BREATHABLE**



**SOLID SHAPE**



**PRESSURE ULCER TREATMENT PLAN**



**READY FOR USE**

**Superior pressure redistribution due to the combination of immersion and offloading**

**Nine adjustable compartments for maximum stability**

**Extra positioning of the upper legs**

The Vector O2 is designed to provide a high level of skin protection, immersion, pressure redistribution and offloading of the IT's. The Vector O2's compartment design provides comfort, superior legs positioning and pelvic stability and is 100% machine washable. The mesh fabric encourages air flow and breathability, for optimal micro climate control and a dry sitting surface. The vector O2 offers support where needed, resulting in improved comfort, skin care and functionality.

### PRODUCT PERFORMANCE

<b>Skin protection / Anti decubitus</b>	▲▲▲▲▲
Pressure redistribution	▲▲▲▲▲
Shear reduction	▲▲▲▲△
Micro climate control	▲▲▲▲▲
Impact & vibration damping	▲▲▲▲▲

### Positioning

Lateral stability	▲▲▲▲▲
Frontal stability	▲▲▲▲▲
Sliding prevention	▲▲▲▲▲
Allows manual adjustments	▲▲▲▲▲
Allows easy transfers	▲▲▲▲△

### Maintenance & Safety

Durability	▲▲▲▲▲
Reliability	▲▲▲▲▲
Functionality when misused	▲▲▲▲△
Low maintenance level	▲▲▲▲▲
Level of hygiene	▲▲▲▲▲

### Functionality & Application

Comfort	▲▲▲▲▲
Low cushion weight	▲▲▲▲▲
Available size range	▲▲▲▲▲
Maximum user weight	▲▲▲▲▲
Low seat to floor height	▲▲▲▲▲
Auto adjustments	▲▲▲▲△

### USED WITH

Spinal cord injuries, neuromuscular diseases, hypermobility syndrome, Ehlers Danlos Syndrome (EDS)

### TECHNICAL SPECIFICATIONS

Height	2" & 4"   6 & 10 cm
Average weight	1.1 - 1.9 lbs   500 - 850 g
Max. user weight	550 lbs   250 kg
Machine washable	60°C max.

### CUSHION SIZES

- Standard
- Custom

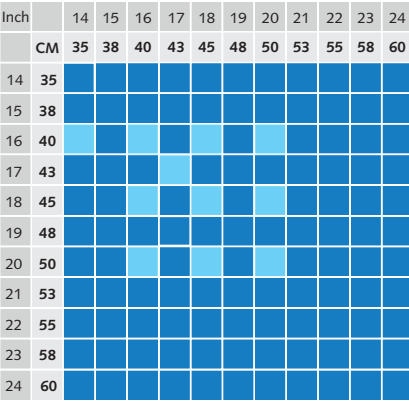

## THE OPTIMAL CUSHION FOR WHEELCHAIR USERS WITH BODY ASYMMETRY

Follows the body's contours for equal pressure distribution | Support IT-coccyx area | Managing pelvic asymmetry

Pre-ischial bar limits sliding forward | Converts shear into normal forces



Thigh support

Mid height zip closure for easy adjustment when client is seated | Cushion keeps its shape, enhancing the user's skin protection

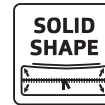
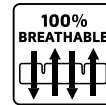

### Individual solution for asymmetry

### Minimizes sliding and shear forces

### Optimal adjustment to the body's contours for equal pressure distribution

The Adjuster O2 is very suitable for use with asymmetric body contours and amputations. It automatically manages small obliquities and is individually adjustable to support more extreme asymmetry. When you're looking for a high comfort level, optimal skin protection and stability: **the Adjuster O2 is always a safe choice.** The design allows total immersion to equally redistribute pressure and limits sliding forward. 100% machine washable and breathable, for optimal hygiene and perfect temperature and moisture regulation. As a result the Adjuster O2 offers you optimal protection against skin breakdown.

#### PRODUCT PERFORMANCE

<b>Skin protection / Anti decubitus</b>	▲▲▲▲▲
Pressure redistribution	▲▲▲▲▲
Shear reduction	▲▲▲▲▲
Micro climate control	▲▲▲▲▲
Impact & vibration damping	▲▲▲▲▲

#### Positioning

Lateral stability	▲▲▲▲△
Frontal stability	▲▲▲▲▲
Sliding prevention	▲▲▲▲▲
Allows manual adjustments	▲▲▲▲▲
Allows easy transfers	▲▲▲▲△

#### Maintenance & Safety

Durability	▲▲▲▲▲
Reliability	▲▲▲▲▲
Functionality when misused	▲▲▲▲△
Low maintenance level	▲▲▲▲▲
Level of hygiene	▲▲▲▲▲

#### Functionality & Application

Comfort	▲▲▲▲▲
Low cushion weight	▲▲▲▲▲
Available size range	▲▲▲▲▲
Maximum user weight	▲▲▲▲▲
Low seat to floor height	▲▲▲▲▲
Auto adjustments	▲▲▲▲△

#### USED WITH

Hemiplegia (CVA), amputations, foot propulsion, kyphosis, pelvic obliquity/tilt/rotation, Spina Bifida, spasms, Fibrodysplasia Ossificans Progressiva (FOP)

#### TECHNICAL SPECIFICATIONS

Height	2" & 4"   6 & 10 cm
Average weight	1.2 - 1.7 lbs   534 - 769g
Max. user weight	550 lbs   250 kg
Machine washable	60°C

#### CUSHION SIZES

- Standard
- Custom

Inch		14	15	16	17	18	19	20	21	22	23	24
CM		35	38	40	43	45	48	50	53	55	58	60
14	35	■	■	■	■	■	■	■	■	■	■	■
15	38	■	■	■	■	■	■	■	■	■	■	■
16	40	■	■	■	■	■	■	■	■	■	■	■
17	43	■	■	■	■	■	■	■	■	■	■	■
18	45	■	■	■	■	■	■	■	■	■	■	■
19	48	■	■	■	■	■	■	■	■	■	■	■
20	50	■	■	■	■	■	■	■	■	■	■	■
21	53	■	■	■	■	■	■	■	■	■	■	■
22	55	■	■	■	■	■	■	■	■	■	■	■
23	58	■	■	■	■	■	■	■	■	■	■	■
24	60	■	■	■	■	■	■	■	■	■	■	■



# VICAIR® ACTIVE O2

## FOR THE ACTIVE WHEELCHAIR USER

**Ischial Well** – Two compartments for superior pressure reduction in the IT-coccyx area and extra positioning possibilities

**Trochanter support** Firmer density to provide lateral stability and to redistribute pressure to help create an ischial well.



Features nifty storage pouch for personal items

Ergonomically-shaped foam for easy transfers

**SmartCell** – Foam barrier prevents sliding forward



### Perfect for users who transfer frequently

### Excellent lateral and frontal stability

### Superior ischial offloading and protection

The Vicair Active O2 offers the unique combination of ergonomically shaped foam and Vicair SmartCells. The four rear SmartCell compartments provide a high level of comfort and skin protection, and offload the seat bones and tailbone area. The foam front compartment makes transfers easy. It also gives a great sense of stability and better wheelchair handling. The foam inlay is protected by an easy-to-clean waterproof cover. The rest of the cushion is 100% machine washable and breathable for optimal hygiene and perfect temperature & moist regulation. The Active O2 has an easy accessible storage pouch for personal items (keys, phone, wallet). In short: everything you need to maintain your active lifestyle!

#### PRODUCT PERFORMANCE

<b>Skin protection / Anti decubitus</b>	▲▲▲▲▲
Pressure redistribution	▲▲▲▲▲
Shear reduction	▲▲▲▲▲
Micro climate control	▲▲▲▲△
Impact & vibration damping	▲▲▲▲▲

#### Positioning

Lateral stability	▲▲▲▲▲
Frontal stability	▲▲▲▲▲
Sliding prevention	▲▲▲▲▲
Allows manual adjustments	▲▲▲▲▲
Allows easy transfers	▲▲▲▲▲

#### Maintenance & Safety

Durability	▲▲▲▲▲
Reliability	▲▲▲▲▲
Functionality when misused	▲▲▲▲△
Low maintenance level	▲▲▲▲△
Level of hygiene	▲▲▲▲△

#### Functionality & Application

Comfort	▲▲▲▲▲
Low cushion weight	▲▲▲▲△
Available size range	▲▲▲▲△
Maximum user weight	▲▲▲▲▲
Low seat to floor height	▲▲▲▲▲
Auto adjustments	▲▲▲▲△

#### USED WITH

Spinal cord injuries, active users with a high transfer frequency

#### TECHNICAL SPECIFICATIONS

Height	2" & 3.5"   6 & 9 cm
Average weight	1.5lbs   700 g
Max. user weight	441lbs   200 kg
Machine washable	60°C (without foam)

#### CUSHION SIZES

- Standard
- Custom

Inch	14	15	16	17	18	19	20	21	22	23	24
CM	35	38	40	43	45	48	50	53	55	58	60
14	35										
15	38										
16	40										
17	43										
18	45										
19	48										
20	50										
21	53										
22	55										
23	58										
24	60										

## THE OPTIMAL PEDIATRIC CUSHION

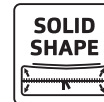
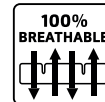

### Especially designed for children

### Filled with small-sized SmartCells for optimal pressure redistribution

### Built to provide carefree mobility

The Vicair Junior Vector O2 is designed for the child's physique. Based on the Vicair Vector O2 and filled with small-sized junior SmartCells, it provides optimal pressure redistribution and comfort. You will appreciate the excellent stability and positioning possibilities of this cushion. It offers a solution for children with muscle disorders and spasms

100% machine washable and breathable, for optimal hygiene and perfect temperature and moisture regulation.

The Vicair Junior Vector O2 keeps the child comfortable, safe and protected.

#### PRODUCT PERFORMANCE

<b>Skin protection / Anti decubitus</b>	▲▲▲▲△
Pressure redistribution	▲▲▲▲▲
Shear reduction	▲▲▲▲△
Micro climate control	▲▲▲▲△
Impact & vibration damping	▲▲▲▲▲

#### Positioning

Lateral stability	▲▲▲▲▲
Frontal stability	▲▲▲▲▲
Sliding prevention	▲▲▲▲▲
Allows manual adjustments	▲▲▲▲▲
Allows easy transfers	▲▲▲▲△

#### Maintenance & Safety

Durability	▲▲▲▲▲
Reliability	▲▲▲▲▲
Functionality when misused	▲▲▲▲△
Low maintenance level	▲▲▲▲△
Level of hygiene	▲▲▲▲△

#### Functionality & Application

Comfort	▲▲▲▲▲
Low cushion weight	▲▲▲▲▲
Available size range	▲▲▲▲▲
Maximum user weight	▲▲▲▲▲
Low seat to floor height	▲▲▲▲▲
Auto adjustments	▲▲▲▲△

#### USED WITH

Spasms, muscle disorders

#### TECHNICAL SPECIFICATIONS

Height	3"   9 cm
Average weight	1 lbs   450 g
Max. user weight	220 lbs   100 kg

#### CUSHION SIZES

- Standard
- Custom

Inch	10	11	12	13	14
CM	25	28	30	33	35
10	Standard	Standard	Standard	Standard	Standard
11	Standard	Standard	Standard	Standard	Standard
12	Standard	Standard	Standard	Standard	Standard
13	Standard	Standard	Standard	Standard	Standard
14	Standard	Standard	Standard	Standard	Standard



## EXPLORE YOUR POSSIBILITIES

Ergonomically shaped back part for seamless fit to the shape of your lower back.

Vicair SmartCells for skin protection



Easily adjustable straps to provide comfort and to follow the body

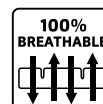

### Stays with you during activities

### Skin protection

### Extremely light, to support optimal mobility

Active as you are, not all of your activities require or allow the use of a wheelchair. In these situations the Vicair AllRounder O2 keeps you comfortable and helps to protect your skin. It is easily buckled onto your body, and follows you around wherever you go.

Feel protected and secure during your sports and outdoor activities, when you sit in a normal chair or on any hard surface, or when you play on the ground. Afterwards you can simply put the entire AllRounder O2 in the washing machine then hang it up to dry and you are ready for your next adventure together. Experience the freedom and explore your possibilities!

\* Special order – not a stocked product

#### PRODUCT PERFORMANCE

<b>Skin protection / Anti decubitus</b>	▲▲▲▲△
Pressure redistribution	△△△△△
Shear reduction	△△△△△
Micro climate control	▲▲▲▲▲
Impact & vibration damping	▲▲▲▲△

<b>Positioning</b>	△△△△△
Lateral stability	△△△△△
Frontal stability	△△△△△
Sliding prevention	△△△△△
Allows manual adjustments	△△△△△
Allows easy transfers	△△△△△

<b>Maintenance &amp; Safety</b>	▲▲▲▲△
Durability	▲▲▲▲▲
Reliability	▲▲▲▲▲
Functionality when misused	△△△△△
Low maintenance level	▲▲▲▲△
Level of hygiene	▲▲▲▲▲

<b>Functionality &amp; Application</b>	▲▲▲▲△
Comfort	▲▲▲▲▲
Low cushion weight	▲▲▲▲▲
Available size range	▲▲▲▲▲
Maximum user weight	▲▲▲▲▲
Low seat to floor height	△△△△△
Auto adjustments	△△△△△

#### USED WITH

Activities outside of the wheelchair  
When seated on hard surfaces for long periods of time.

#### TECHNICAL SPECIFICATIONS

Height	n.a.
Average weight	1.8 lbs   800 g
Max. user weight	220 lbs   100 kg

#### CUSHION SIZE

AOD - Small  
AOD - Medium  
AOD - Large

**Determining the correct hip width** Measure the width of your hips to check which size matches the size of your body. When seated, hold a tape measure horizontally above the widest point of your upper legs, closely against the front of your hips. Do not follow your leg contours, keep the tape measure straight. Measure from A to B (or B to A). Choose the larger size if the measured size is in between two sizes.

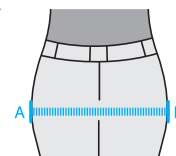



36 compartments with dynamic SmartCell air-filling

Double rings on the 4 corners of the mattress, to loosely attach bedsheets to prevent "hammocking".



Combination of middle layer and low friction mattress cover to minimize shear force and optimize immersion



### Vicair Inlay Sections

- Fits commercially available mattresses with levelling pad sections.
- Clinically Proven High-performance pressure distribution for stage I-IV decubitus ulcers.
- Easy to set up. Cells may be removed or added easily for proper immersion where necessary
- Light weight and portable at 4lbs/1.8kg
- User Weight Limit 550lbs/250kg



## Optimal pressure redistribution

## Pain relief

## Extremely suitable for immobile users

Pain relief, unrest reduction, pressure ulcer prevention. These are just some examples of the immediate relief provided by the Vicair Mattress 415.

The design offers optimal pressure redistribution, reduction of shear forces, optimal immersion and stable—yet comfortable—positioning. Even with existing decubitus stage I-IV (clinically proven).

If a situation requires an individual solution, custom sizes and shapes are available on request.

The Vicair Mattress 415 is low maintenance and comes with a fluid proof cover. It can be used on any type of bed frame and bed frame position (e.g. fowler's position). CPR can be performed on a patient without the use of a board. The Vicair SmartCell air-filling makes the Vicair Mattress 415 an extremely lightweight and non-powered alternative to other air-technique replacement mattresses.

### Available in 2 sizes:

- 36" x 20" | 91.4 x 50.8 cm
- 36" x 19" | 91.4 x 48.3 cm

### USED WITH

Pressure ulcers (stage I-IV), rheumatism, burn victims, terminal illness, spasms, kyphosis, pain management.

### TECHNICAL SPECIFICATIONS

Height	7.9"   20 cm
Average weight	22 lbs   10 kg
Max. user weight	550 lbs   250 kg

### CUSHION SIZES

- Standard
- Custom

Inch	27	28	30	32	34	36	38	40	42	44	46	48
CM	68	70	75	80	85	90	95	100	105	110	115	120
56												
72												
74												
76												
78												
80												
82												
84												
86												
88												

# CUSTOM MADE ENDLESS POSSIBILITIES

Medical practitioners often work with complex cases in the field of seating and positioning. Generally our Vicair Adjuster O2 and Vector O2 cushions are able to offer a solution, but sometimes it is necessary to provide a solution that is custom made for the client. For those situations it is possible to create a Vicair Custom Made seat or back cushion.

For more than 20 years Vicair has been creating products specifically designed for clients with complex disabilities or with specific body contours. The flexibility of the Vicair technique, based on SmartCells, makes this relatively easy to do. Our R&D team department consists of a medical doctor, a product manager and a product designer.

The request for a Vicair Custom Made product is usually made by one of the product specialists of our distributors. They work closely together with the medical practitioner in the process of ordering the Vicair Custom Made product.

First, the specific case is discussed in a Vicair R&D team meeting. Based on the description of the client's medical background and needs, the R&D department is able to start designing the product and creates a 3D drawing. The drawing will be discussed with the product specialist and the medical practitioner. After the design has been approved, the production of the cushion commences. Vicair has its own Product Design Studio, so within a few weeks the Vicair Custom Made product is ready to be shipped. The medical practitioner further guides the installation of the product.

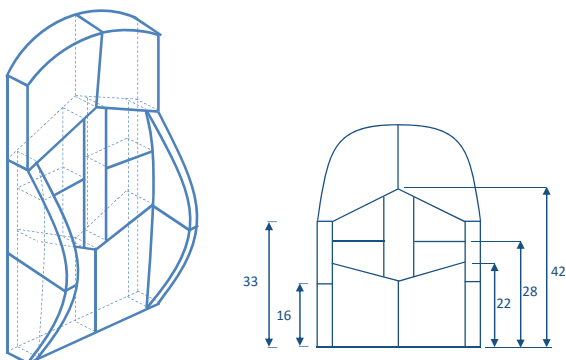

# QUALITY WARRANTY ISO

## Quality

Vicair is devoted to the development and production of products that will positively influence the daily comfort of the wheelchair user, to offer him or her as much freedom as possible to focus on something other than their disability.

We expect our products to be of very high quality, to ensure a reliable and safe result. During production all procedures and processes are performed as documented in our quality management system, in which we have implemented the applicable ISO standards and CE regulations.

## Warranty

Vicair offers a limited warranty against defects in workmanship and materials for a period of 24 months after the original date of purchase, provided the product has been used normally.

Any damage arising from abnormal use, or caused by improper handling, cleaning, or negligence, is excluded from this warranty. Should a defect in materials or workmanship occur within 24 months from the original date of purchase, Vicair will, at its own choice, repair or replace the product free of charge. The cushion cover is excluded from this warranty.

Remedies for breach of express warranties herein are limited to repair or replacement of the product. In no event shall damages for breach of any warranty include any consequential damages or exceed the cost of non-conforming goods sold.

## ISO Certified

Vicair is ISO 13485 certified. This means it has a comprehensive quality management system for the design and manufacture of medical devices.

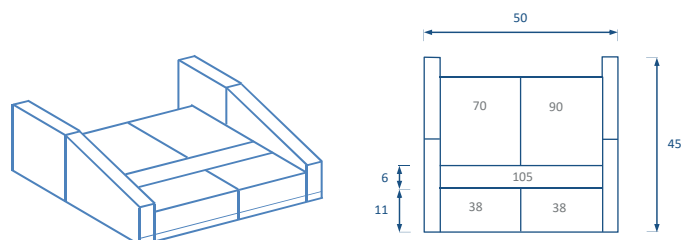



The VICAIR logo is displayed in a bold, white, sans-serif font with a registered trademark symbol (®) to the upper right of the 'R'. It is set against a black rectangular background that is part of a larger graphic design featuring overlapping blue and red geometric shapes.

DISTRIBUTED IN CANADA:



753011 Second Line EHS  
Orangeville, Ontario L9W 5W4  
T: (866) 875-2877  
F: (866) 875-2878  
E: [orders@dynamichcs.com](mailto:orders@dynamichcs.com)  
[www.dynamichcs.com](http://www.dynamichcs.com)

Follow us on



AVAILABLE FROM: