

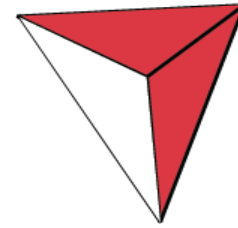

FUTURE
MOBILITY HEALTHCARE INC.



PRISM



USER MANUAL

1 CONTACT INFORMATION

FUTURE MOBILITY HEALTHCARE INC. APPRECIATES YOUR FEEDBACK

Supplier: Please give this manual to the user of the wheelchair.

User: Please read this entire manual before using this wheelchair.

Thank you for choosing Future Mobility Healthcare Inc.

If you have any questions please do not hesitate to write or call us at the address and telephone number below:

Future Mobility Healthcare Inc.

Customer Service Canada

6750 Professional Court

Mississauga ON L4V 1X6

Phone: (888) 737-4011 or (905) 671-1661

Fax: (905) 671-3377

e-mail: orderdesk@futuremobility.ca

www.futuremobility.ca

TABLE OF CONTENTS

1 CONTACT INFORMATION	2
TABLE OF CONTENTS.....	3
2 NOTICE – READ BEFORE USE	4
CHOOSE THE CORRECT CHAIR AND OPTIONS.....	4
REVIEW THIS MANUAL OFTEN.....	4
3 GENERAL	4
4 HARDWARE KIT CONTENTS	6
5 TOOLS REQUIRED	6
6 BEFORE INSTALLATION	7
.....	8
BEFORE INSTALLATION	8
THE CANE CLAMPS IS DESIGNED TO FIT 1” DIAMETER WHEELCHAIR BACK POSTS. SANTOPRENE CANE INSERTS ARE PROVIDED, WHICH CAN BE PLACED INSIDE THE CANE CLAMPS TO ALLOW THE BACK TO BE INSTALLED ONTO 7/8” WHEELCHAIR BACK POSTS (SEE FIG. 3 BELOW).	8
.....	9
7 PRISM BACK INSTALLATION INSTRUCTIONS	9
PRISM BACK INSTALLATION INSTRUCTIONS	10
PRISM BACK INSTALLATION INSTRUCTIONS	12
PRISM BACK INSTALLATION INSTRUCTIONS	13
8 DISENGAGING THE PRISM BACK	14
9 HEAD/NECK MOUNTING SUPPORT	15
10 PRISM TRUE FIT BACK	16
CUSTOMIZATION OF FOAM CUBES	16
11 PRISM AIR BACK	16
12 MAINTENANCE	17
CLEANING INSTRUCTIONS.....	17
13 WARRANTY	18
LIMITATIONS AND EXCLUSIONS	19

2 NOTICE – READ BEFORE USE

CHOOSE THE CORRECT CHAIR AND OPTIONS

Future Mobility Healthcare Inc. provides a choice of many wheelchair styles to meet the requirements of the wheelchair user. However, the final selection of the wheelchair and its options rests solely with you and your health care advisor. Choosing the best chair will depend on such things as:

1. The level of your disability, strength, balance and coordination.
2. The places and terrain that you are likely to use your chair.
3. The need for options for your safety and comfort (such as anti-tip tubes, positioning belts, or special seating systems).

REVIEW THIS MANUAL OFTEN

Before using this chair you, and each person who may assist you, should read this entire manual and make sure to follow all instructions. Review the warnings often.

WARNING

The term “**WARNING**” are hazards or unsafe practices that may cause **severe injury or death** to you or to other persons.

3 General



WARNING

NOTICE: Information contained within this document is subject to change without notice.

 **WARNING:** DO NOT install this equipment without first reading and understanding this instruction booklet. If you are unable to understand these instructions, contact a healthcare professional, dealer or technical personnel before attempting to install this equipment - otherwise, injury or damage may occur.

NOTE: Check all parts for shipping damages before using. In case of damage, **DO NOT** use the equipment. Contact the Equipment Supplier for further instructions.

4 **Hardware Kit Contents**

- 1- Back mounting Plate LT
- 1- Back mounting Plate RT
- 2 - Cane Clamps
- 4 - Cane Inserts
- 6 - Depth/Recline Adjustment Screws
- 6 - Cane Clamp Screws
- 2 - Backing Plate

5 **Tools Required**

- Wrench: 1/2"
- Allen Key: 3/16"
- Tape Measure / Ruler

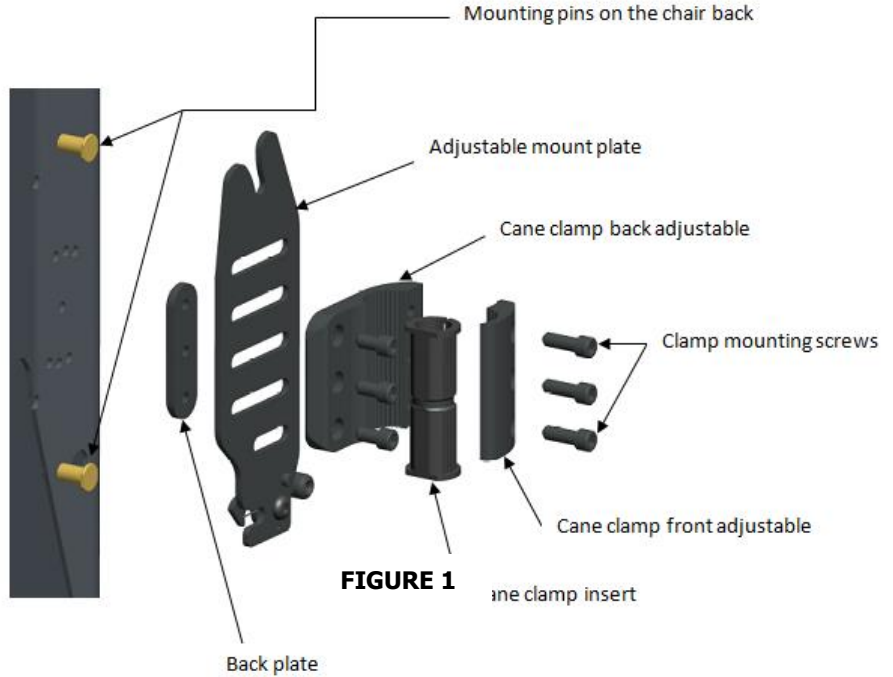

6 Before Installation

! PLEASE NOTE

When establishing the mounting position for the MAX mounting Hardware, please insure the stability of the wheelchair is not compromised.

Adjusting the forward and aft position of the backrest will alter the user's center of gravity within the wheelchair. A recessed back position can significantly reduce the rearward stability of the wheelchair. Similarly a more forward back position will reduce the wheelchair's forward stability.

The Back mounting Plates and the Cane Clamps are shipped pre-assembled with the hardware oriented in the forward most back position (see Fig. 1 below). By altering the orientation of the Cane Clamps with the Back mounting Plates, the hardware can be positioned to provide a rear most mounting position for the back if desired (see Fig. 2 below).

To make the adjustment from the forward most to the rearmost position (or vice versa), detach the Back mounting Plates from each Cane Clamp by removing the 3 Depth/Recline Adjustment Screws. Then turn the Cane Clamp 180° and re-attach it to the mounting Plate in its original orientation.

The MAX Hardware offers users a full 5" range of forward and rear adjustability (Angle adjustment forward 15°, back 20°). Each mounting plate provides an individual adjustment range of 1.5".

Front of wheelchair
←



Back Mounting Plate in the forward most back position

Front of wheelchair
←



Back Mounting Plate in the rear most back position

Before Installation

The Cane Clamps is designed to fit 1" diameter w **FIGURE 2** posts. Santoprene Cane Inserts are provided, which can be placed inside the Cane Clamps to allow the back to be installed onto 7/8" wheelchair back posts (see Fig. 3 below).

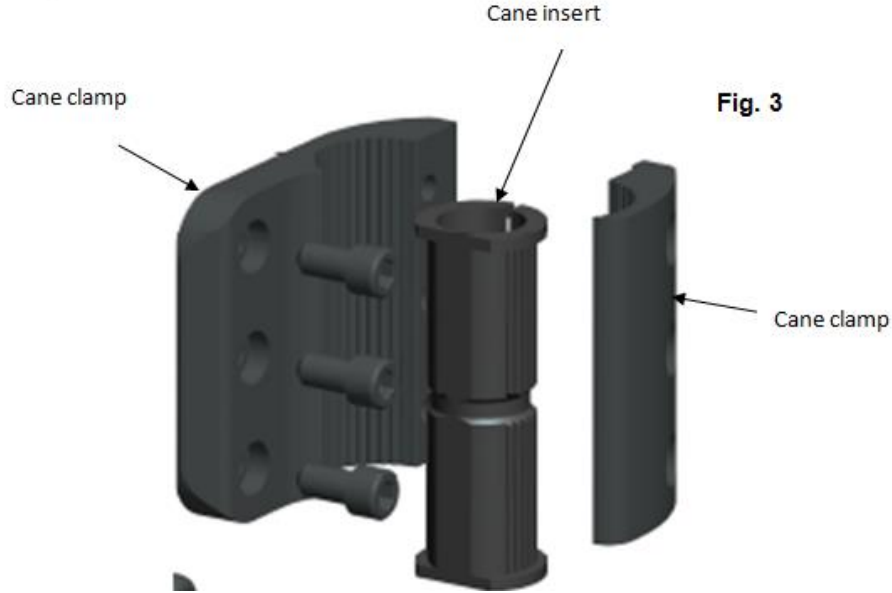
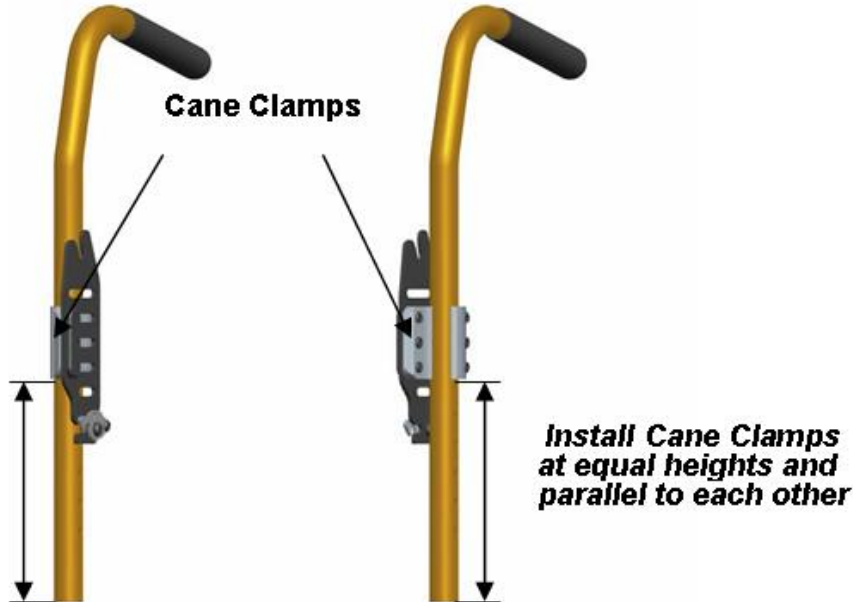

FIGURE 3

7 Prism Back Installation Instructions

1. Determine the appropriate Back mounting Plate set-up/ configuration for the user(per Section 3.0) .

2. Loosen the Cane Clamp Screws (3 per clamp) in order to open the clamp enough to fit around the back posts (Install clamps inserts if required).
3. Starting on one side, position the Cane Clamp at the desire height on the back post and tighten the clamp screws enough to hold it in place.(Clamps will be fully secured ones the back is installed and all final adjustments are made) .
4. Using a ruler, measure the exact height of the installed cane Clamp from a fixed point on the wheelchair, and install the second Cane Clamp at the same height on the opposite back post (see Fig. 4 below). Please ensure the Cane Clamps are also mounted parallel with each other.



Prism Back Installation Instructions

PRISM BACK

! PLEASE NOTE

Additional upper and lower adjustment slots are provided on the MAX Hardware Back mountings Plates to allow alternate mounting heights when back post obstacles are encountered. Using the Alternate mounting Slots will increase or decrease the back heights by 7/8". However using the lower slot will decrease the range of available depth and angle adjustment

850 REV07 REV DATE:12/14/2018

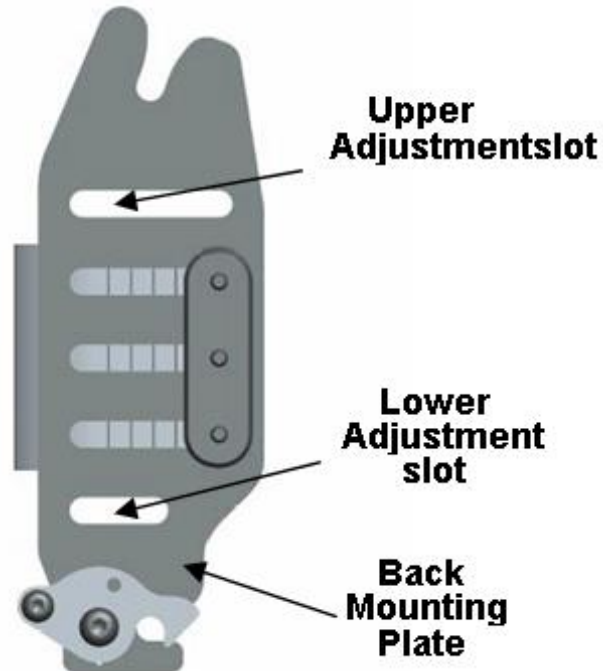

FIGURE 5

Prism Back Installation Instructions

1. To Install the MAX Back onto the back mounting plates please refer to the Instructions and diagram (see Fig. 5 below).

Step 1: Insert the upper mounting plate into hooked slot on the top of the back mounting plates.

Step 2: Ensure that the LT detent latch is in the closed position.

Step 3: With the upper pins in place, snap lower pins into the latch mechanism at the bottom of the back mounting plates.

2. In order to install the longer mountings Pins, first remove the outer cover from the back.

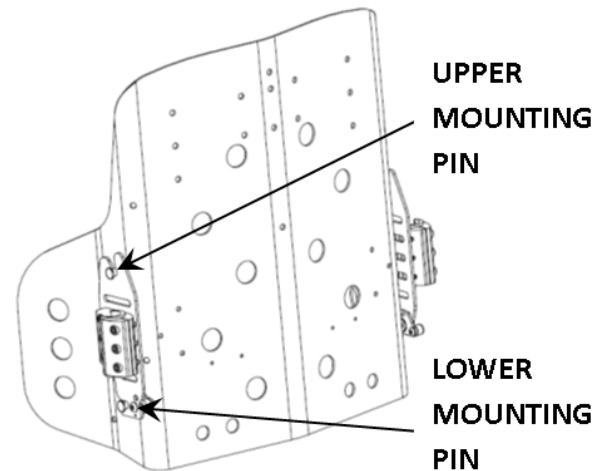

! PLEASE NOTE

Our standard MAX Back accommodate wheelchair seat frame sizes up to 2" wider than the actual back width. Each MAX Back are shipped with the standard mounting pins installed a set of longer pins for 1" wider and 2" wider seat frames can be purchased separately.

Prism Back Installation Instructions

3. To install the longer mounting pins, please refer to the instructions bellow
 - Remove the back from the wheelchair and secure in place.
 - Using wrench, loosen the inside nut and replace standard pins to the longer pins
 - Carefully tighten nuts to secure the pins in place.

Ensure the pins do not rotate when tightening nuts.

4. Check that the fit and alignment of the back is correct
5. Fully tighten the Cane Clamp Screws on each side of the back
6. Once the back is properly secured to the back canes, the user can be seated in the wheelchair in order to establish the optimal depth and recline settings for the back. With the user in the chair, loosen the Depth/Recline Adjustment Screws, position the back at the desired depth and recline angle, and re-tighten the screws to lock in place.

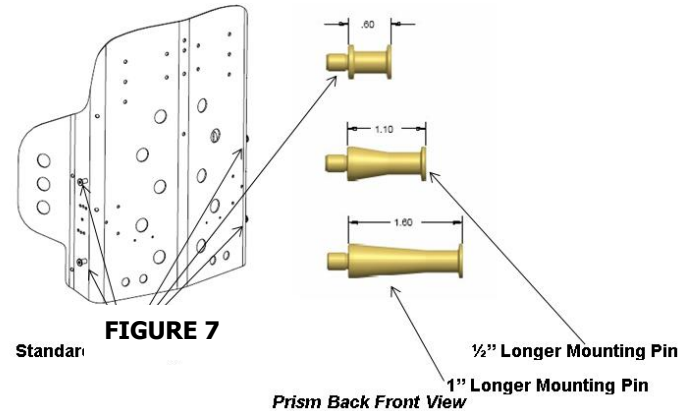
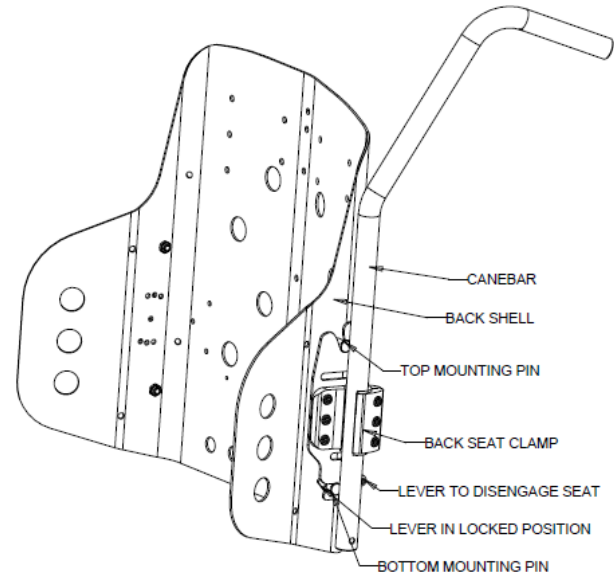

FIGURE 6

8 Disengaging the Prism Back

To Disengage the Back from the wheelchair:

- I. Push the release lever downwards on the left mounting plate until the ball plunger engages the latch open position.
- II. Push the release lever on the right mounting plate.
- III. Lower mounting pins will automatically ejected from the mounting plates(see Fig. 6 below)
- IV. Once the lower pins are released, lift the back up and out of the upper slots on the mounting plates.



9 Head/Neck mounting Support

The Prism Backs have (3) sets of holes on the top edge of the shell where the Headrest Adaptor Bracket attaches to the shell. With the Universal Adaptor Bracket, most standard types of headrest can be mounted.

Instructions for installing a Headrest clamp:

1. Open outer cover and determine which set of holes to use to attach the Adaptor Bracket. The Bracket may be shifted 1.5" left or right depending on the user requirements.
2. Close the cover and carefully punch (2) holes through the cover fabric that match the determined mounting holes.
3. Open the front of the cover to access the appropriate mounting holes.
4. Push the mounting screws outward through the back shell and fabric. Place the Headrest Clamp with locknuts in-line with screws on the outside of the back cover.
5. Tighten both screws and close the cover.

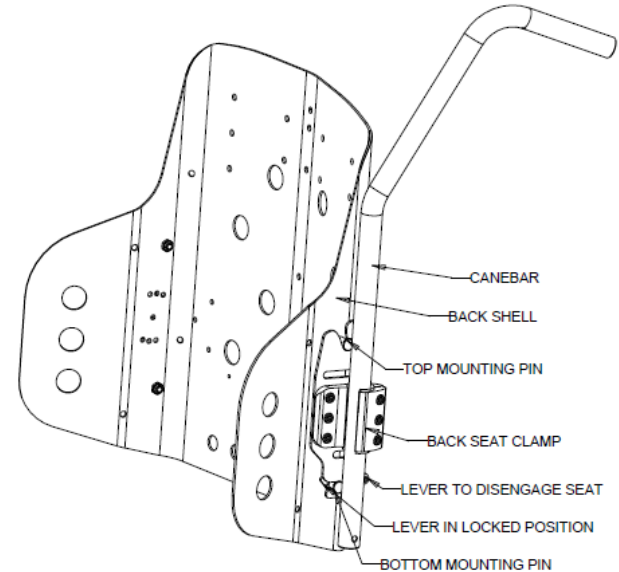

10 PRISM True Fit Back

Please follow the instructions within this booklet to: determine mounting position of Back, install hardware; mount, install and remove Back; and set up back angle of the MAX True Fit Back.

Customization of foam cubes

1. Remove cover and outer foam pad from shell.
2. Install shell on chair and mark the foam cubes to be trimmed based on clients requirements.
3. Remove the foam blocks to be modified from the shell (foam is secured using hook and loop fastener).
4. Bend the foam block at the space next to the cube to be cut or carved.
5. Trim each cube to the desired length using a sharp knife or scissors (foam cutting saw works best).
6. Reinstall trimmed foam blocks onto the aluminium shell.
7. Replace outer foam pad and cover.

11 PRISM AIR BACK

1. Installation procedure is identical to other MAX Back models (see above).

To Adjust Air Inserts

1. Unzip cover, fold both flaps back, separate foam pad from shell and gently remove air bladder from back panel (insert is held in place with hook and loop fasteners). Reposition to desired height, reattach hook and loop fastener and zip cover.
2. Inflate lumbar and lateral inserts by squeezing bulb valve until positioning is attained. Remove air from insert by pressing button on bulb valve.

12 Maintenance

Cleaning Instructions

Back Assembly

Clean with a dampened cloth on a regular basis depending on usage. Wipe entire surface.

! PLEASE NOTE

Visual inspection of all parts, mounting assemblies, foam and upholstery materials for any deformation, corrosion, breakage or wear is recommended. Check all fasteners on a regular basis to ensure that all connections remain secure.

Cover

USE mild detergent and machine -wash cold using gentle cycle. DO NOT USE fabric softeners or bleach. DO NOT machine dry - air dry in shady area.

! PLEASE NOTE

The cover is designed to protect the foam against a user's incontinence and to be fire retardant, so the MAX Back's must not be used without their covers. If the cover is torn, it must be replaced.

Foam

If the MAX Back foam becomes contaminated due to incontinence, the foam pad CAN be replaced independently. Foam can be purchased separately by ordering through Future Mobility Products' Customer Service.

13 Warranty

This warranty is extended only to the original purchaser/user of our products. Future Mobility Healthcare Inc. warrants its positioning products to be free from defects in materials and workmanship for three (3) years on backs, one (1) year on hardware and 90 days on covers, upon normal usage by original purchaser. If within this warranty period the product shall be proven to be defective, such product shall be repaired or replaced, at Future Mobility Healthcare Inc. discretion. Future Mobility Healthcare Inc. sole obligation and your exclusive remedy under this warranty shall be limited to the repair and/or replacement of the product or its parts. This warranty does not include any labor or shipping charges incurred in replacement part installation or repair of any product.

For warranty service, please contact the dealer from whom you purchased your Future Mobility Healthcare Inc. product. In the event you do not receive satisfactory warranty service, please write directly to Future Mobility Healthcare Inc. at 6750 Professional Court, Mississauga, Ontario, L4V 1X6. Provide the

dealer's name, address, model number, and date of purchase and indicate the nature of the defect.

DO NOT return products to Future Mobility Healthcare Inc. without our prior consent. The defective unit or parts must be returned for warranty inspection within thirty (30) days of the return authorization date. (Future Mobility Healthcare Inc. will issue a return authorization number). Please prepay all shipping charges; C.O.D. shipments will be refused.

LIMITATIONS and EXCLUSIONS

This warranty shall not apply to problems arising from normal wear or failure to adhere to the enclosed instructions. Products subjected to negligence, accident, improper usage, maintenance or storage; or products modified without Future Mobility Healthcare Inc. written consent including, but not limited to: modification through the use of any unauthorized parts or attachments; products damaged by reason or repairs made to any component without the specific consent of Future Mobility Healthcare Inc. or products repaired by anyone other than a Future Mobility Healthcare Inc.

WARRANTY PROCEDURES

1. If within this warranty period the product shall be proven to be defective, such product shall be repaired or replaced, at FMHI discretion.
2. FMHI's sole obligation and your exclusive remedy under this warranty shall be limited to the repair and/or replacement of the product or its parts.
3. This warranty does not include any labor or shipping charges incurred in replacement part installation or repair of any product.
4. For warranty service, please contact the dealer from whom you purchased your FMHI product. In the event you do not receive satisfactory warranty service, please write directly to FMHI.
5. DO NOT return products to FMHI without our prior consent. The defective unit or parts must be returned for warranty inspection within thirty (30) days of the return authorization date. (FMHI will issue a return authorization number). Please prepay all shipping charges; C.O.D. shipments will be refused.

The foregoing warranty is exclusive and in lieu of all other expressed warranties. It shall not extend beyond the duration of the expressed warranty provided herein and the remedy for violations of any implied warranty shall be limited to repair or replacement of the defective product pursuant to the terms contained herein. FMHI shall not be liable for any consequential or incidental damages whatsoever

----- **Cut below this line #**

Warranty Registration Form

To validate your Future Mobility HealthCare warranty, please complete the below form and return it the address at the end of this form. Visit online at www.futuremobility.ca for more Future Mobility Products.

Name: _____
Street Address: _____
City/Country/Postal Code: _____
Telephone: _____
Purchased Date: _____
Purchased From (Dealer Name & Address): _____
Product Purchased: _____
Serial Number: _____

Print and Mail it to:
Future Mobility Healthcare Products
6750 Professional Court
Mississauga, Ontario, L4V 1X6
Fax: 905-671-3377

CANADA

Future Mobility Healthcare Inc.

6750 Professional Court

Mississauga, ON L4V 1X6

Ph: 905 671-1661 – Toll Free: 1 888 737-4011

Fax: 905 671-3377

Toll Free Fax: 1-866-670-3377

e-mail:customerservice@futureamobility.ca

www.futuremobility.ca



FUTURE MOBILITY

INNOVATIVE SEATING AND HOME MOBILITY SOLUTIONS

USA

Future Mobility Products US LLC

1 Buffalo River Place

Buffalo, NY, 14210

Tel: 716-783-9130 – Toll Free 1-855-938-

898873

Fax: 716-783-9236

Toll Free Fax: 1-866-670-3377

e-mail:customerservice@futureamobility.ca

www.futuremobility.ca



FUTURE MOBILITY

PRODUCTS