

Pro Angler
Skeg Line Kit



2 Tools Needed

1. #2 phillips screwdriver
2. #3 phillips screwdriver
3. Drill
4. 5/16" drill bit
5. Needle nose pliers
6. 7/16" wrench
7. 2nd 7/16" wrench or socket
8. 1/12" wrench
9. Lighter (optional)
10. Tubing and grommet
11. 5/16" panel rivet
12. PA Skeg Line Kit

Installation

①

Remove the 4 screws from the steering cover plate.

If the skeg line exits the hull at the front of the box, continue with this upgrade. If the skeg line comes from the side, you do not need to do this and can skip to step 5.

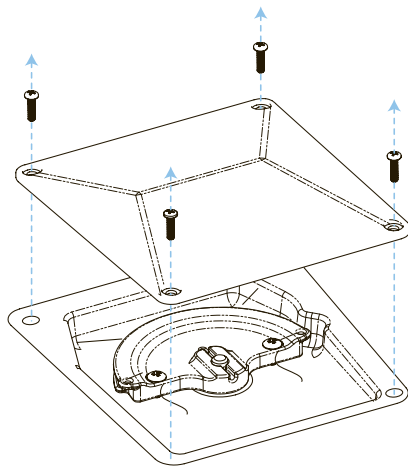
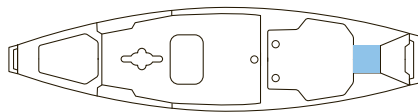

②

Turn your boat on its side or upside down and remove the 4 screws from the skeg housing

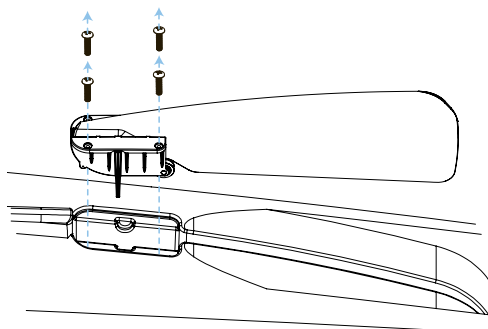
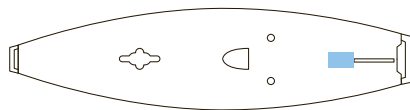

③

Release the skieg line from the cleat. Without removing the skieg from the housing, remove the screw and bolt from the pulley and pivot. Untie and remove the line.

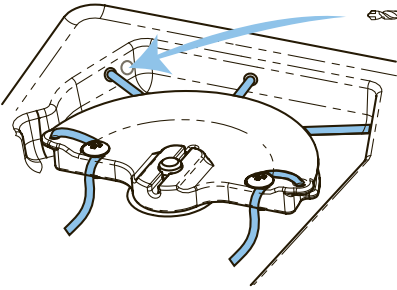
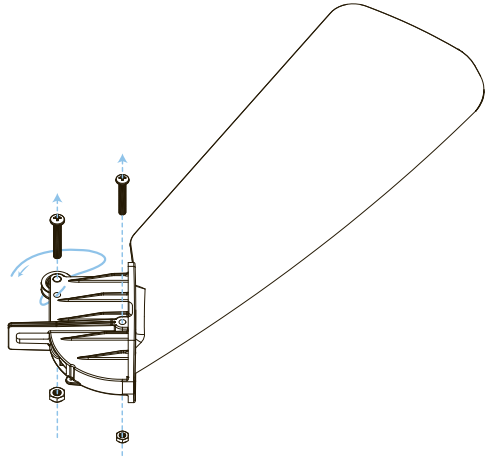

④

Using the 5/16" bit, drill a hole halfway between the steering line and front of the steering box.

⑤

Mount the turning block on the port side of the kayak.

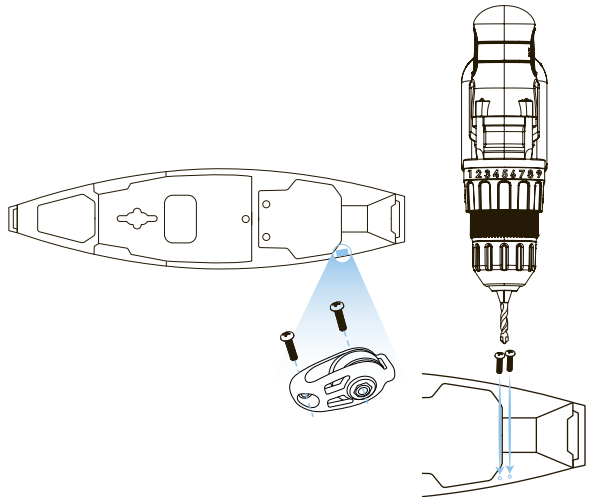

⑥

Reach inside the rear hatch and pull the skag line out from the back. Using the new line provided, tie a simple knot in the line. Tie another simple knot in the original line around the new line to create a slip knot and pull tight to create tension.

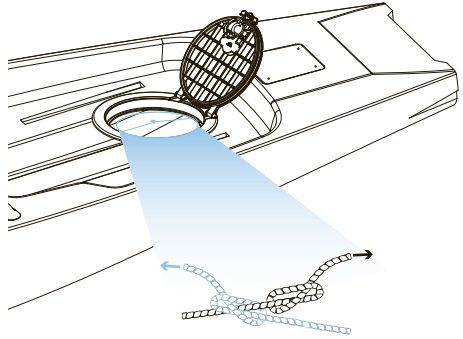

⑦

Reroute the new skag line around the block and through the new hole ensuring that the line goes above the steering lines that criss cross at the back of the tankwell.

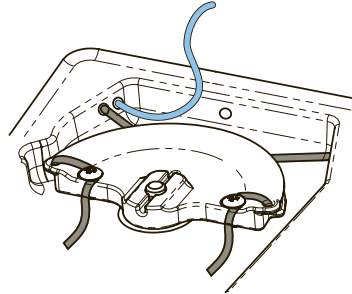

⑧

Feed the line through the tube and grommet from the kit. You may need to burn the end of the line to help feed it through. Pass the skag line through the scupper hole.

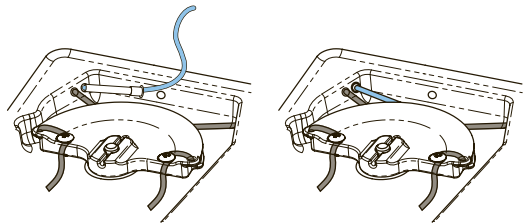
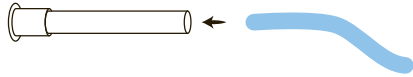

⑨

Pass the line through the hole in the skag so it goes toward the hole on the side of the housing. Pass the line through the hole in the side of the housing. Tie a figure 8 knot to prevent the line from backing out.

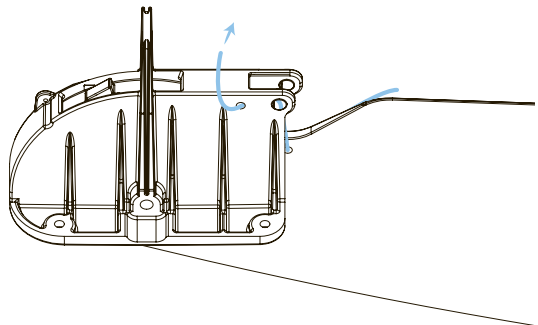

10

Reinstall the pulley and screw ensuring that the line is between the pulley and the housing. Do not overtighten, the pulley should spin freely.

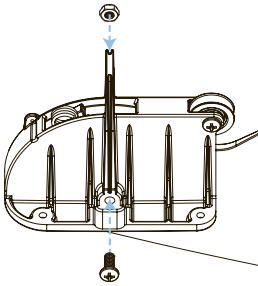
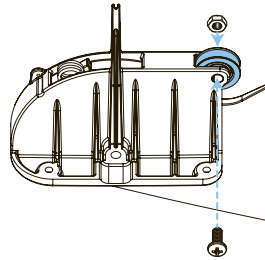

11

Install the pivot bolt. Do not overtighten, the skag should move freely.

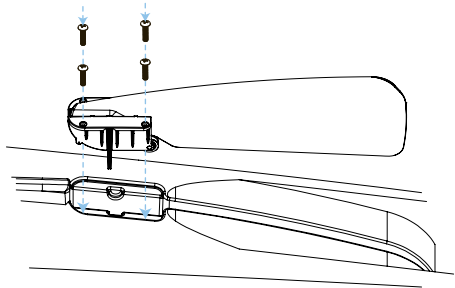

11

Reinstall the keel housing using the 4 screws.

12

With the boat upright and the rear of the boat raised of the ground, test the function of the skag. If it functions properly, reinstall steering cover.

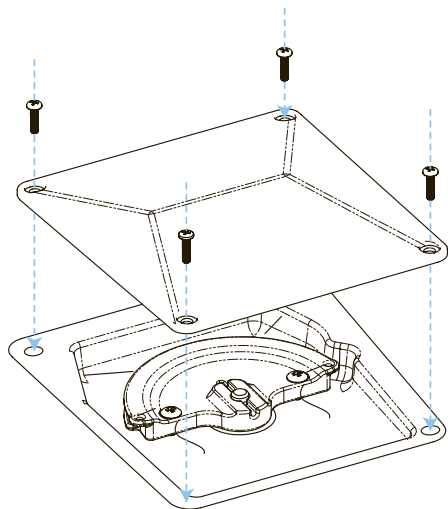



Hobie Cat Company

Holding Company
Oceanside, California, USA
1-800-HOBIE-49
hobie.com

Hobie Cat Australasia

Subsidiary
Huskisson, New South Wales, Australia
1-800-4-HOBIE
hobie.com

Hobie Cat Europe

Subsidiary
Toulon, France
+33(0)494 08 78 78
hobie.com

Hobie Kayak Europe

Independent Distributor
Stellendam, The Netherlands
+31(0)187 499 440
hobie.com

Hobie Cat Brasil

Independent Distributor
Porto Belo, Santa Catarina, Brazil
+55 (21) 3942 6815
hobie.com