



KOMOS

STAINLESS STEEL COMMERCIAL KEGERATORS

INSTRUCTION MANUAL



TABLE OF CONTENTS

Included Features	2
General Instructions	3
• Safety.....	3
• Installation.....	3
Assembly Instructions	4–11
Operation Instructions	12–14
• Operation.....	12–13
• Care/Maintenance	14
• Couplers/Connections.....	14
Troubleshooting	15
Technical Specs	15

⚠ SAFETY NOTICE ⚠

CO₂ may be dangerous if not used in a well ventilated area. It is important to always check for gas leaks after setting up the unit as well as when kegs are replaced.

⚠ WARNING ⚠

If the unit has just been moved (or tilted at more than a 45 degree angle) DO NOT PLUG IN OR TURN ON until the unit has been upright for 24 hours.

INCLUDED FEATURES

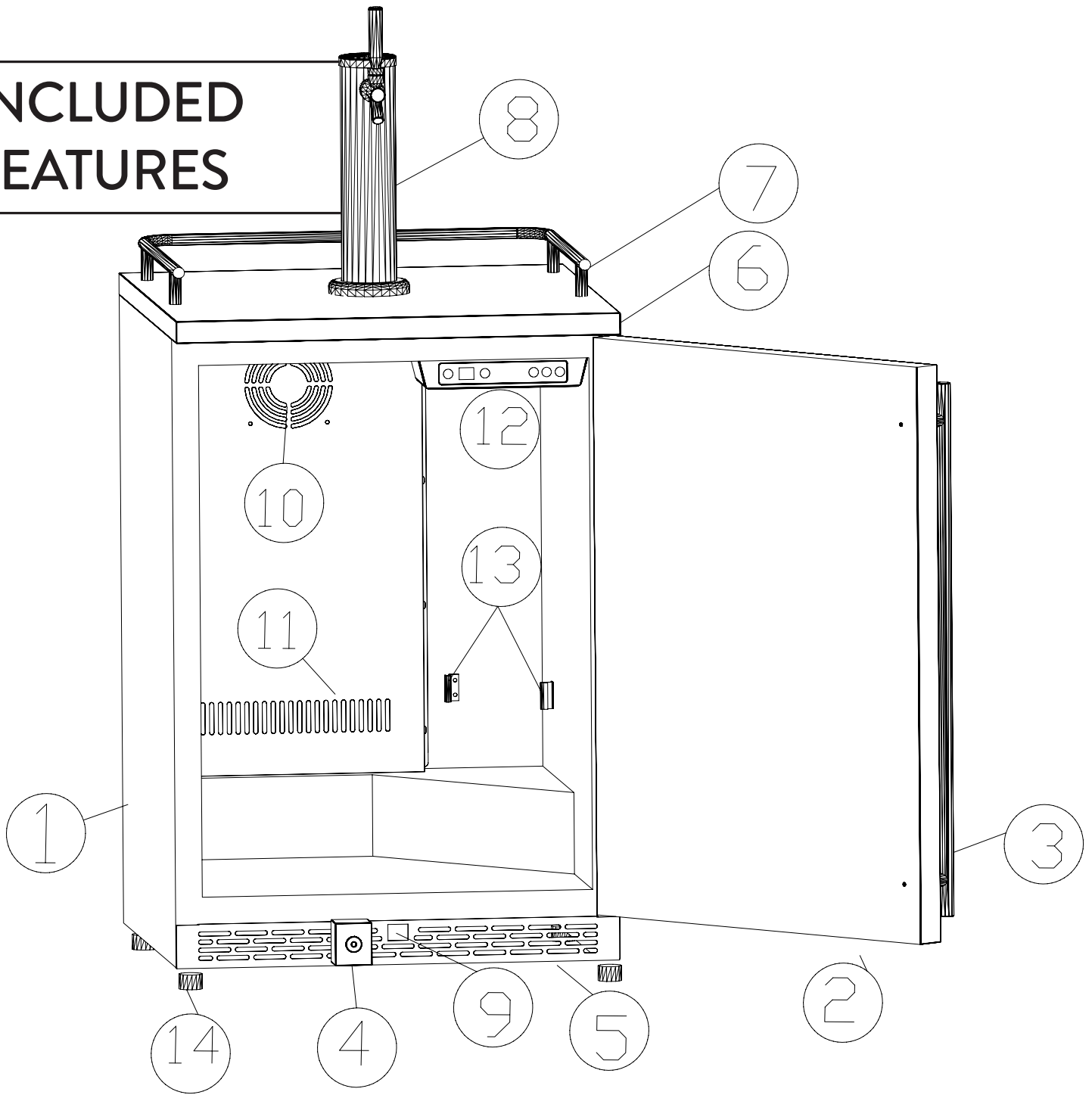

- | | |
|---------------------------|---------------------------------------|
| 1. Cabinet | 9. Light Switch |
| 2. Door | 10. Fan |
| 3. Stainless Steel Handle | 11. Return-Airway |
| 4. Lock | 12. Control Panel |
| 5. Vent | 13. Strap For CO2 Tank |
| 6. Top Cover | 14. 4 Adjustable feet |
| 7. Guard Rail | 15. 4 Optional Casters (Not Pictured) |
| 8. Tower, Faucet & Handle | |

GENERAL INSTRUCTIONS

To ensure the kegerator is properly used please review and follow the safety and installation notices below.

Safety:

- Plug into a grounded 3-prong outlet.
- Do not use extension cords or adapters to connect the unit to an electrical power source.
- The fuse for the outlet where the unit will be plugged in should be at least 15 amps.
- The kegerator should not be installed in an area where it will be exposed to any water.
- Never allow children to climb inside the appliance. If no longer in use - remove the door or secure shut so children cannot become trapped inside the unit.
- **California Proposition 65 Warning:** This product contains a chemical or chemicals known to the State of California to cause cancer and birth defects or other reproductive harm.

Installation:

- After moving the unit it is best to allow it to stand upright for 24 hours prior to plugging in to the power source.
- Do not pinch/kink the power supply cord.
- For proper heat dissipation make sure there is sufficient and proper air ventilation around the kegerator. The kegerator dispenser vents from the grill below the door. The right side is “cold air in” and the left side is “warm air out”. Make sure the kegerator can vent adequately from the front vent. This will allow the heat to escape quickly enough to ensure consistent cooling. Not installing properly may cause the kegerator to fail prematurely and void the warranty.
- Place out of direct sunlight and other sources of heat. The best room temperature range is from 65°F– 80°F.
- Once the unit is in place, level it by adjusting the feet on the bottom.
- Clean the interior with a soft damp washcloth.
- And finally, after plugging in the kegerator allow it to cool down for 4 hours prior to putting a keg inside.

ASSEMBLY INSTRUCTIONS

Assemble the kegerator prior to installing/plugging in the unit.

To assist in assembly we suggest having the following tools on hand:

- Multi-purpose wrench (included)
- Allen wrench (included)
- #1 Phillips head screwdriver
- Tubing cutter or scissors

If Using Stepless Clamps Instead of Duotight:

- Needle-nose pliers
- Pinch clamp pliers (preferred)
- If you don't have pinch clamp pliers, regular wire cutters will work

Take stock of what comes with the kegerator.

Remove all the items from inside the unit and unpack the tower box and tubing bag. You should have:

1. CO₂ tubing
2. Beer line tubing
3. Intertap Faucet(s) with black tap handle
4. Tower collar (hides tower screws)
5. Tower gasket
6. Tower shank with Duotight tailpiece
7. Multi-purpose wrench
8. CO₂ tank strap
9. Stainless drip tray
10. Guard rail with 4 screws
11. Door handle with 2 screws
12. Allen wrench for guard rail & handle
13. Feet knobs (4)
14. Casters (4)
15. Long casters screws (8)
16. Short casters screws (8)
17. Tower to kegerator screws (4)
18. Lock key (2)
19. Duotight tees (Included with 2 & 3 faucet towers only)
20. Stepless clamps (Included in case Duotight connections are not used)

Attach The Casters/Adjustable feet:

Depending on where you plan to place your kegerator, attaching casters is optional. If you would like to use the casters, then it is recommended to attach the casters before installing the tower and CO₂ tank. This step is simple, however you will need to place the unit on its backside. For this reason you will want to **WAIT 24 HOURS** after attaching the casters before plugging in the unit. We recommend placing a piece of cardboard or a cloth under the unit to prevent dents and scratching.

NOTE 1: There are two pairs of casters - 1 pair with a lock & 1 pair without. The two locking casters should be fastened at the front of the unit.

NOTE 2: There are a total of 16 screws for your casters, 8 long & 8 short. The 8 long screws are for the outer holes shown below in red. The 8 short screws are for the inner holes shown below in yellow. See image to the right.



1. Empty the unit.

Remove the 4 original adjustable feet.

Unscrew the **BACK** lower left & lower right side screws from the base plate and set aside (these will be longer screws).

Lineup the **NON-LOCKING** casters with the 4 pre-drilled holes. Use the 4 longer screws (red circles) on the outer holes and the 4 short screws (yellow circles) on the inner holes and tighten.



2. Unscrew the **FRONT** lower left and lower right side screws from the base plate and set aside (these will be longer screws).

Lineup the **LOCKING** casters with the 4 pre-drilled holes. Use the 4 longer screws (red circles) on the outer holes and the 4 short screws (yellow circles) on the inner holes and tighten.

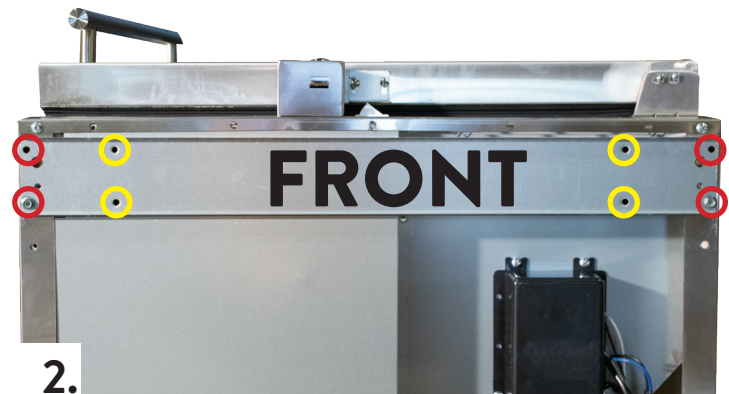

Attach The Guard Rail:

1. Place the guard rail on top of the kegerator and align the rail holes with the mounting pegs.
2. Secure the guard rail to the kegerator by tightening the provided screws with the provided Allen wrench.
3. Once done tightening, pull back slightly on rail to ensure it has been fully secured. If any give is felt continue tightening until it feels secure.

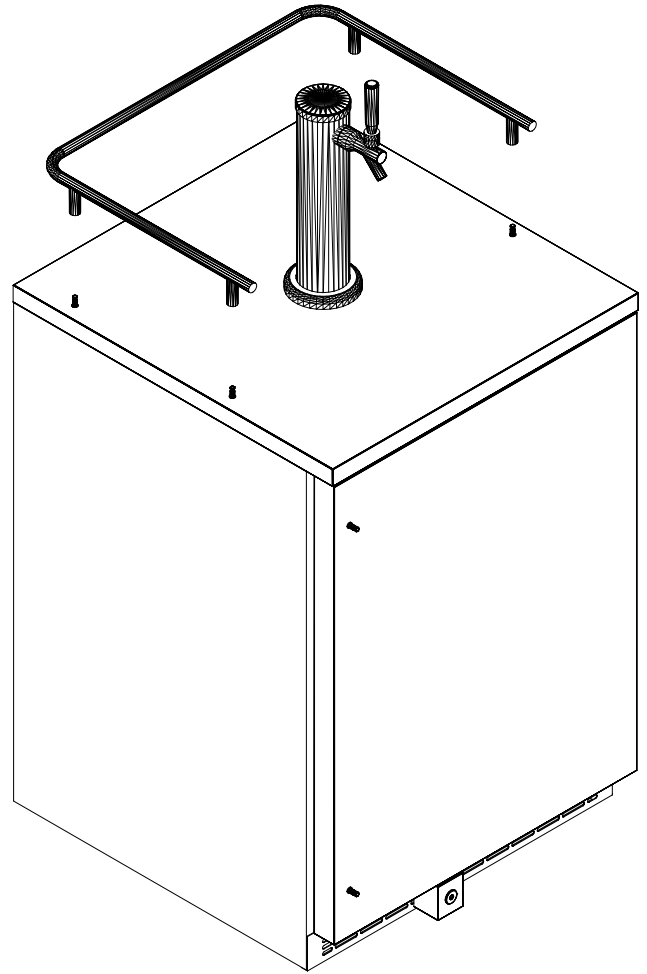
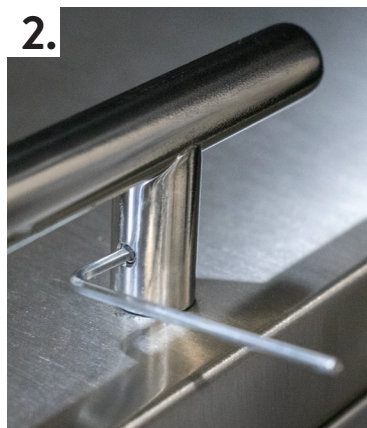
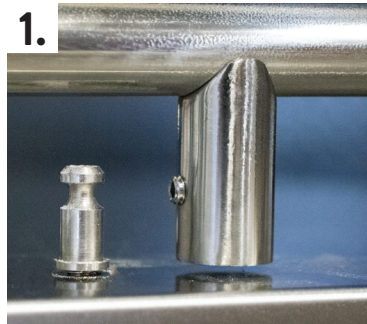

Attach The Door Handle:

1. Align the 2 holes in door handle with the 2 pegs on the door.
2. Use the supplied screws and Allen wrench to tighten. Once done tightening, pull back slightly on handle to ensure it has been fully secured to the door. If any give is felt continue tightening until handle feels secure.



Assemble The Tower:

Whether you have a single, double, or triple faucet tower the process is the same.

TIP: For those setting up a triple faucet tower - start with the lowest faucet.

1. Set the tower's bottom collar sleeve onto tower.



2. Feed the beverage line tubing up through the bottom of the tower so tubing comes out both the top and the bottom of the tower.



3. Attach the Duotight fitting to the beverage line coming from the top end of the tower. Feed the Duotight fitting and tubing through the tap hole. To attach the Duotight fitting, push the fitting onto the tubing then pull back slightly to lock in place. **NOTE:** repeat this step for each additional faucet your tower has.



4. Locate the tower shank and remove the nut and white convex collar and set them aside. From the outside of the tower, attach the Duotight fitting to the tower shank. Slide the shank and tubing into the faucet hole.



5. Turn the tower upside down. Slip the white convex collar and shank nut onto the beverage line with the white convex collar first and the shank nut second.

6. Using your finger to hold the tower shank in place, align shank with convex collar first and then the shank nut and tighten by hand.



7. Next tighten the shank nut with the included multipurpose wrench.

8. Attach the faucet to the shank; tighten with the included multipurpose wrench. Attach the tap handle and tower cap.

Attach The Tower:

Attach the tower to the kegerator.

1. Remove the 4 screws from the top of the kegerator and set aside.
2. Place the tower gasket onto the kegerator and align the gasket holes with the pre-drilled holes.
3. Drop tubing from the bottom of the tower through the hole into the kegerator.
4. Align the tower with the pre-drilled holes and screw into place using the 4 screws you removed in “Step 1”.

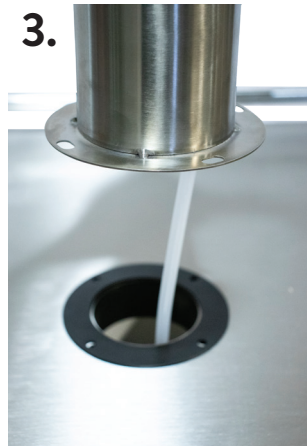

Insert Tower Cooling Hose:

The Tower Cooling Hose is the large diameter corrugated hose coming off the back fan. To cool the tower effectively we want to fit the cooling hose into the tower and have it reach the top.

NOTE: The hose is intentionally long because some may choose to install the tower onto a raised counter rather than directly onto the kegerator.

1. The easiest way to measure the tubing is to insert it into the tower until it reaches the top. Once fully inserted (with the extra tubing from the beer lines this can be snug) make an estimate of how many inches need to be cut off. Don't worry, a best guess will work just fine.
2. Pull the hose out, and with scissors or a knife cut the tubing at an angle -- we don't want the hose to push flush against the top of the tower which will restrict airflow.
3. Re-insert the hose into the tower. Don't worry if the tubing is a little short or long, it will properly cool the tower.



Connecting The Gas Line & CO₂ Regulator To The Tank:

We recommend you attach the tubing to the regulator prior to connecting it to the tank. There are two ways to connect your CO₂ regulator. We strongly recommend using a Duotight push-to-connect fitting which is designed to work the EVA Barrier line that is included with your KOMOS Kegeerator.

If Using Duotight Push To Connect Fittings:

Remove nut and barb from the regulator and replace with Duotight fitting. Then tighten by hand an additional 180° turn. Push gas line into Duotight fitting and pull back on tubing slightly to ensure connection. (See Photo Below).



DUOTIGHT FITTING

If Using Stepless Clamps:

Dip tubing in very hot water for 15 seconds to soften. Place stepless clamp onto tubing. Insert needle-nose pliers into tubing and expand the pliers. Connect to the barbed on your regulator. Crimp clamp securely onto tubing. (See Photo Below).



STEPLESS CLAMP

Remaining Steps:

1. Attach the regulator to the tank using the included multipurpose wrench.
2. Tighten firmly, but be careful not to over tighten. NOTE - there must be a regulator gasket between the regulator and tank. Some regulators come with a gasket already attached to the regulator.
3. Using the provided CO₂ tank strap, attach one end to the fixing hook inside the kegeerator. Place the CO₂ tank on its shelf in the right hand corner of the kegeerator. (See Photo Below).
4. Once CO₂ tank is in place, attach the remaining end of the tank strap to remaining fixing hook. (See Photo Below).



DUOTIGHT



CLAMP



3.



4.

CONNECTING THE GAS TUBING & BEER LINE:

Your Komos Kegerator includes very high quality EVA Barrier tubing that is designed to work best with Duotight connectors. Compared to standard PVC tubing, EVA Barrier is a double lined tubing that is BPA free and greatly reduces CO₂ loss.

CO₂ Gas Tubing (larger inner diameter tubing):

The length of your gas tubing won't affect serving the beer. Extra gas line is included to accommodate different set ups. We suggest you cut to length for your set up or roll up the extra and zip tie it. If you have a 2 or 3 faucet tower you will need to cut your gas line and install the Duotight tees to split the gas line.

Beer Line Tubing (smaller inner diameter tubing):

Do not cut the beer line. It is already cut to the correct length to ensure there is enough resistance to reduce foaming.

Using Duotight:

Attach the correct Duotight fittings to the keg coupler or quick disconnects you are using. Duotight fittings should be threaded on as tight as possible by hand and then turned an additional 180 degrees with a wrench. For pictures of additional styles of couplers or quick disconnects see page 14.

Not Using Duotight:

If you did not purchase Duotight fittings and have couplers or quick disconnects with traditional barbs we have included some stepless clamps. Because the EVA Barrier tubing is an advanced two layer tubing it is difficult to fit over barbs. Follow these steps:

1. Boil a cup of water and dip the end of tubing for 15 seconds to soften.
2. Place stepless clamp onto tubing.
3. Insert needle-nose pliers into tubing and expand the pliers to increase the size of the opening.
4. Push tubing onto the barb fitting and crimp the clamp securely with pinch clamp pliers or wire cutter pliers.



Duotight Gas Line Tee

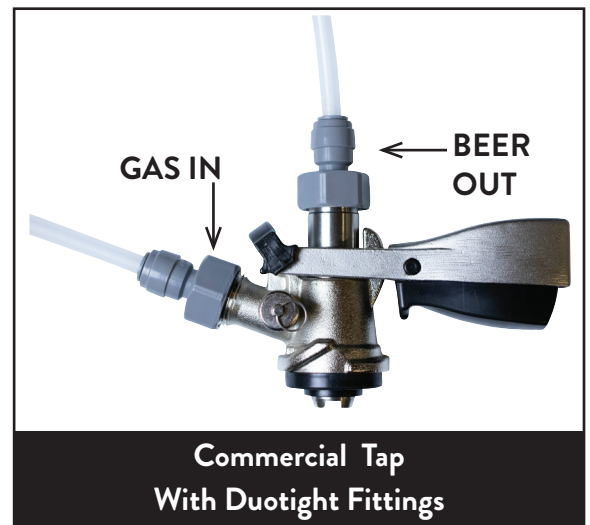

Commercial Tap
With Duotight Fittings

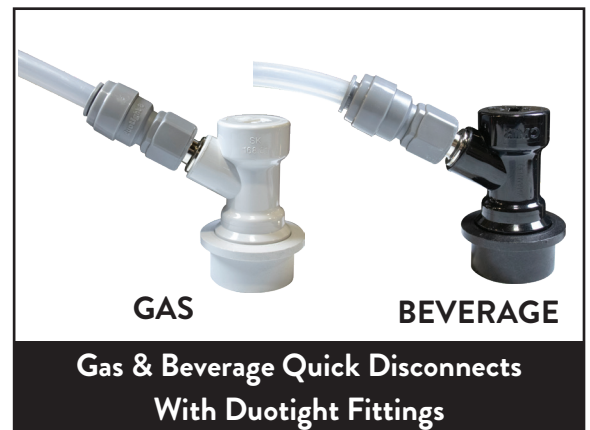

GAS BEVERAGE
Gas & Beverage Quick Disconnects
With Duotight Fittings

Critical Final Step – CO₂ Pressure Check:

Before we start serving the beer we want to confirm that the regulator and all attached hoses are properly sealed so there are no CO₂ leaks in the system. Pressure leaks need to be fixed ASAP because if left unchecked they will cause the CO₂ tank to drain, which can be potentially dangerous if located in a closed area. Testing is relatively straightforward:

Once your system is fully set up:

- Open the CO₂ tank valve.
- Turn up the pressure through the regulator to 20 PSI.
- Turn off the CO₂ tank valve.
- Wait a couple hours then check the pressure on the regulator.

If it has not dropped, then there are no leaks. Release the pressure and reset the regulator to your desired serving pressure.

If there was a drop in pressure, then spray/wipe soapy water on all the points where there may be a leak. Such as:

- All tubing connections.
- Where the regulator attaches to the CO₂ tank.

When gas escapes and hits the soapy water it will create bubbles. Wherever you find these bubbles tighten the connection.

Place The Drip Tray:

Place Drip Tray under the tower... simple as that!



OPERATION INSTRUCTIONS

How To Use The Digital Control Board:

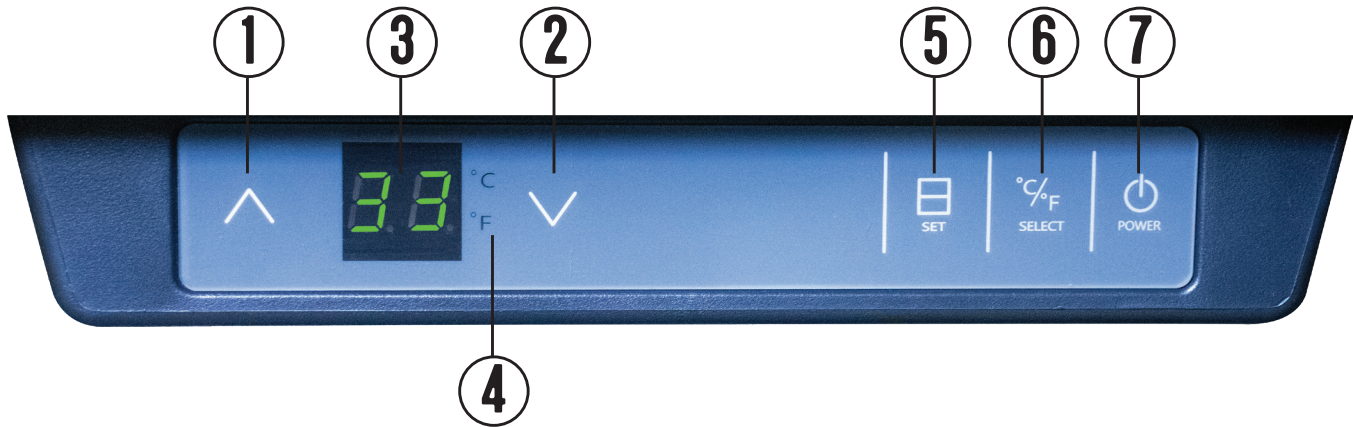

1. UP arrow. Used to raise (warm) the set temperature by 1°F or 1°C. Maximum temperature 76°F or 24°C.
2. DOWN arrow. Used to lower (cool) the set temperature by 1°F or 1°C. Minimum temperature 28°F or -2°C.
3. Temperature Display. The display indicates the current operating temperature.
4. F°/C° Display.
5. Set Temperature. Press this to set the temperature, then press the Up (1) or Down (2) arrow to select your desired temperature. The Temperature Display (3) will flash then count down from the current temperature to your selected temp.
6. The F°/C° button allows you to set the display to read in either Fahrenheit or Celsius.
7. Power Button. Turns the kegerator on or off.

Preset Settings:

- When power is off, the kegerator will save the temperature setting data and remain at that temperature setting when the power is turned back on.

Auto Defrost:

- The kegerator is equipped with an automatic defrost system. During the process of defrosting the compressor will stop working and the interior fan will run continuously. The temperature inside will rise to 42°F. The beer fridge is still running normally. When setting temperature lower (e.g. setting temperature at 32°F), and with a full load of kegs inside, the temperature reading on the display may be higher than the preset temperature. This is not a failure.

Helpful Tips:

- It is normal to see condensation form on the faucet. It is caused by the difference in temperature between the cold beer and the inside of the faucet when beer is flowing through the line.
- To ensure that your beer dispenser works to the maximum efficiency for which it was designed, keep it in a location where there is proper air circulation and electrical outlets.

Beer Temperature:

Correct consistent temperature is an important factor to consider when storing and dispensing draft beer. Therefore, it is best to adhere to the following guidelines:

- Beer can freeze, so it's important to select and maintain proper operating temperatures inside your kegerator. Beer will start to freeze at 28°F (- 2 °C).
- Temperatures too cool or too warm may cause flavor loss, off taste and/or dispensing problems.
- Periodically monitor temperatures inside your kegerator (adjust as necessary).
- Keep the kegerator door closed as much as possible to avoid temperature fluctuations
- A good target temperature for most beers is in the 36°F– 40°F range. However, you will find that certain types will be better served at warmer temperatures.
- At this point the next question on most minds is ... how long will it take to get the keg to serving temperature?! In general, if the keg is at room temperature it can take up to 2 days to chill to proper serving temp, depending on the keg volume. Fortunately most kegs are stored cold so it shouldn't take that long. Still, a keg at 48°F will take roughly 10 hours to cool down to 38°F. **Bottom line – plan ahead and give the beer as long as possible to chill prior to serving.**

Cleaning/Maintenance:

- Do not use any solvent-based cleansers or abrasive pads on the kegerator. Wiping the outside using warm water and a mild liquid detergent with a soft cloth will do the job.
- Beer lines need to be cleaned periodically because of a crystallized build up which forms on the fittings, lines, and taps commonly referred to as “beer stone”. If the beer stone is not completely removed in a cleaning process it will leave an unsanitary surface that can harbor microorganisms, which will cause an undesirable flavor.
- Your beer line should be cleaned approximately once every 2–3 months. The dispenser faucet should be cleaned on a weekly basis or prior to every use if not used on a regular basis. **NOTE** - If you have trouble manipulating the faucet lever, it usually indicates the faucet may require cleaning. **DO NOT** apply force to move the handle in this situation, as this will likely lead to damaging the handle and/or faucet.
- We recommend purchasing a Beer Line Cleaning Kit to make the job of cleaning your line and taps easier!
- About every 6 months it is good practice to clean the front grill of the unit (turn the power off first). This will help maximize the life of the compressor.
- When the kegerator is not in use it is best to remove any beer in your line. First, turn off the CO₂ and dispense beer until no more beer is flowing. This will release pressure in the keg so that the coupler can safely be detached.

Keg Couplers/Connectors:

By now you most likely know which types of kegs you’ll be serving through your kegerator - commercial, homebrew, or maybe both (!?). Below is the list of the coupler options. When purchasing a commercial keg it is best to confirm the Coupler Type with the liquor store/distributor.

Commercial Couplers By Type/System (subject to change):



D TYPE
Most US breweries



S TYPE
Newcastle, Becks, Heineken



U TYPE
Guinness, Harp



A TYPE
Paulaner, Spaten



G TYPE
Anchor, Boddington

Homebrew Disconnects For Corny/Soda Kegs:



BALL LOCK FITTINGS: aka Pepsi-style (most common among homebrewers)
GRAY = Gas Fittings BLACK = Liquid Fittings

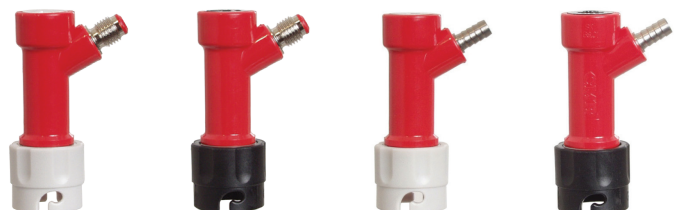

PIN LOCK FITTINGS: aka Coke-style
2 PRONG GRAY = Gas Fittings 3 PRONG BLACK = Liquid Fittings

Trouble Shooting:

Kegeerator does not turn on	Check circuit breaker, fuse and check plugs.
Kegeerator does not seem cold enough	Check temperature setting by placing cup of water with a thermometer inside fridge. Check after 2 hours & compare against set kegeerator temperature. Kegeerator may need to cool longer or the door gasket may not be sealing correctly.
Kegeerator shuts off/on too often	Check to see if the door gasket is sealing correctly. Or the ambient room temperature is too high so the unit is working harder to cool to set temperature
Kegeerator seems to make too much noise	Humming is normal. Gurgling sounds are caused by cooling liquid used by the kegeerator. Or unit may not be level.
Error Code On Temperature Display	E0: Defrost sensor malfunctions. E1: Cabinet inner temperature sensor malfunctions. E2: Short circuit of the sensors or thermostat control board.

CAUTION

- If the unit loses power (unplugged, moved, turned off) you will need to wait 3 minutes before restarting otherwise the unit may not properly turn on and you can cause damage to the compressor.
- When turning on for the first time, or after being off for a few days, the temperature read-out will be off by a few degrees for 3–4 hours. Once the temperature normalizes it will read correctly.

Technical Specifications:

Model #	ND-1600
Dimensions (W x D x H)	With Stainless Steel Top Cover: 23.85" x 24.9" x 35.43" Without Stainless Steel Top Cover : 23.85" x 24.86" x 34.375"
Net Volume Total (cu ft/L)	6.6cu ft/187L
Product Weight Max (lbs/kg)	104lbs/47.5kg
Ambient temperature	32°F–104°F/0°C–40°C
Temperature Range	28.4°F–76°F/-2°C–24°C
Refrigerant Type	R600a
Rated Voltage Frequency	115v/60Hz
Input Power	130W
Current	1.6A
Control Type	Digital Touch Pad
Cooling System	Auto Defrost
Light	LED Interior Light

Distributed By Brewmaster™

Still have issues? Call customer service at 1-800-600-0033