

# The Plastic Pattern Perfect

## Instructions

### Parts List:

Part List ..... 1

### Assembly Steps:

Step 1: Fastening Templates to Table ..... 2  
 Step 2: Pattern Perfect Stylus Bracket Assembly ..... 3  
 Step 3: Stylus to Stylus Bracket Assembly ..... 3  
 User Tips ..... 3  
 Examples of Patterns ..... 4

## Parts List

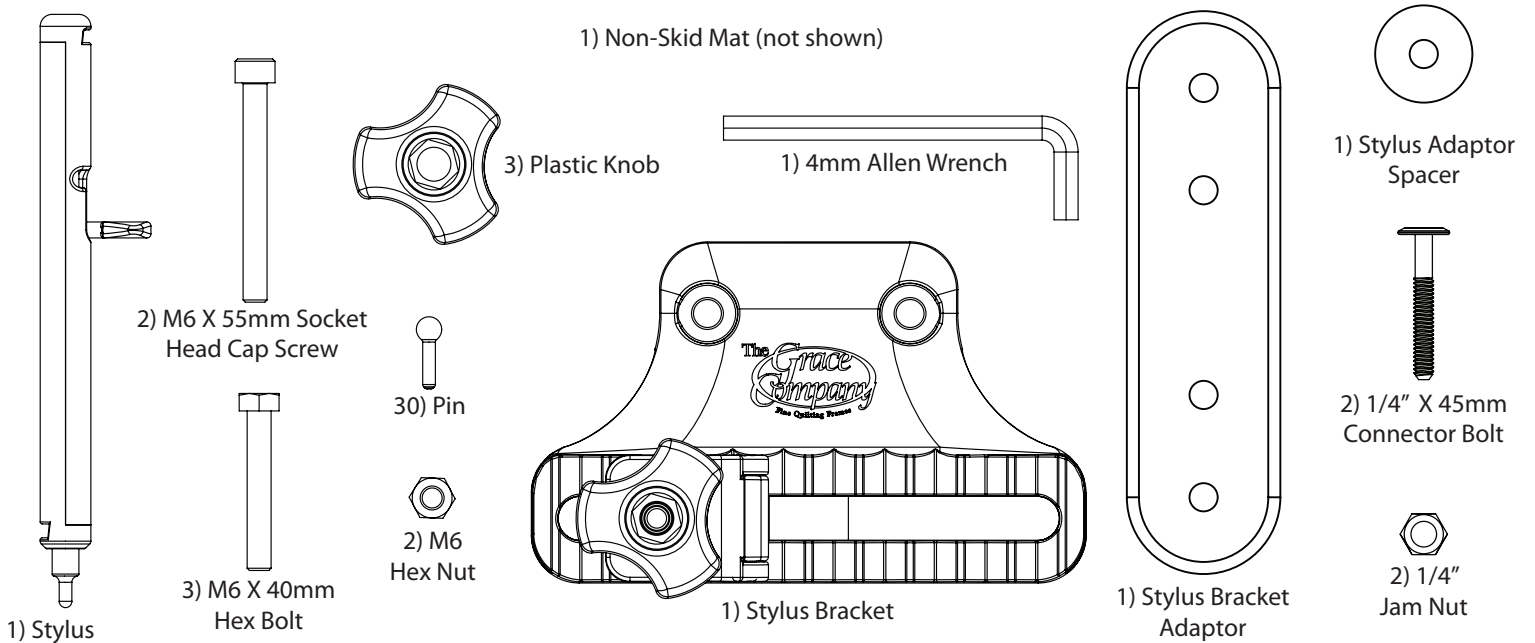
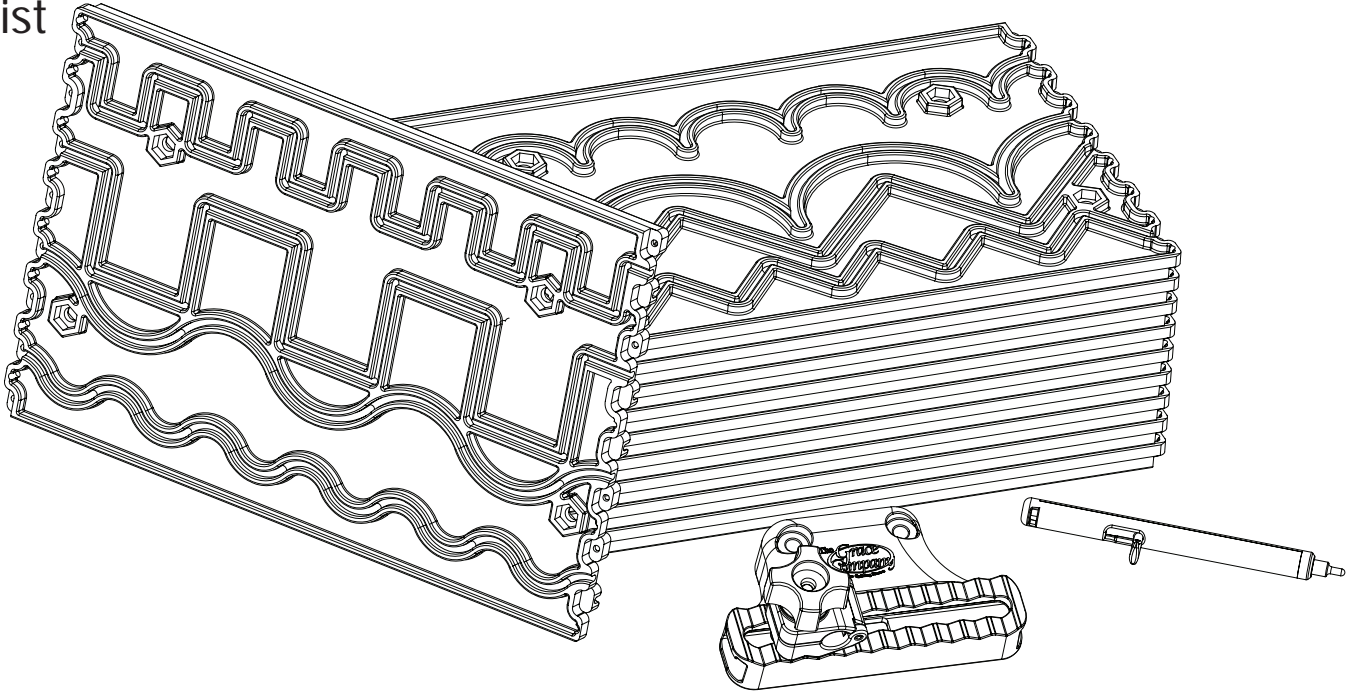

## Step 1: Fastening Templates to Table

Parts Needed: 1-Non-Skid Mat  
3-M6 x 40 Hex Bolt  
3-Plastic Knobs  
Pattern Templates  
Pins

**1-1** Your frame size will determine how many templates you will need.

**1-2** To assemble your templates you will need to decide what patterns you want to line up and put the grooves together. \*\*You have 8 different patterns to choose from (4 on each side).

**1-3** First, lay down the Non-Skid Mat on the table top, making sure there are not wrinkles.

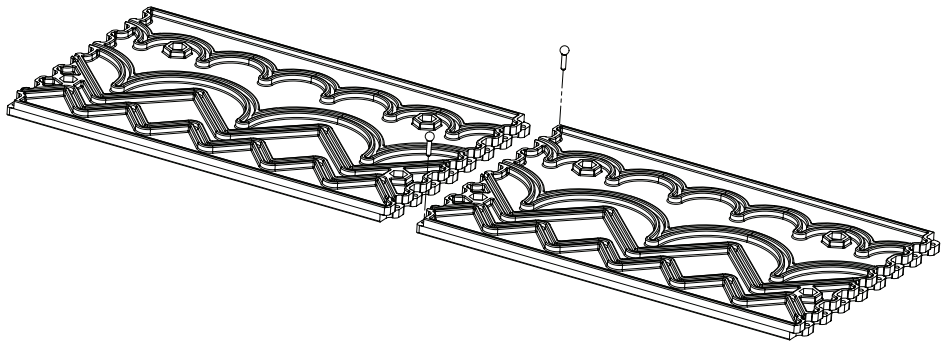

**1-4** Next, determine which pattern set you wish to use, and place that pattern set face-up on the mat. Connect the next template, using a minimum of two Pins, as shown.

**1-5** For added template stability, we recommend you fasten the templates to the table top using a M6x40 Hex Bolt. To do this, find a hole that is near the middle of the template assembly and make sure it lines up with one of the slots in your frame's table. You may need to shift your template assembly slightly to line up the hole with a slot. Put a bolt through the hole in the template, push it through the mat and into one of the table slots.

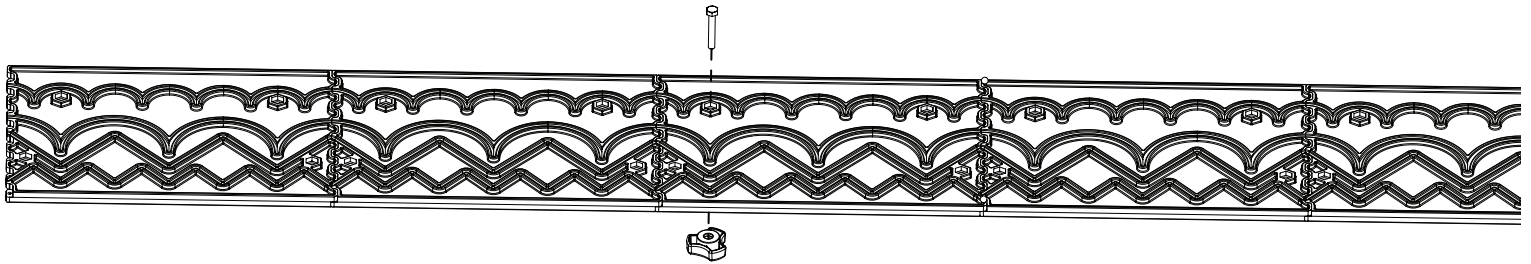

(If necessary you can further secure your patterns by inserting bolts on both ends, as shown below.)

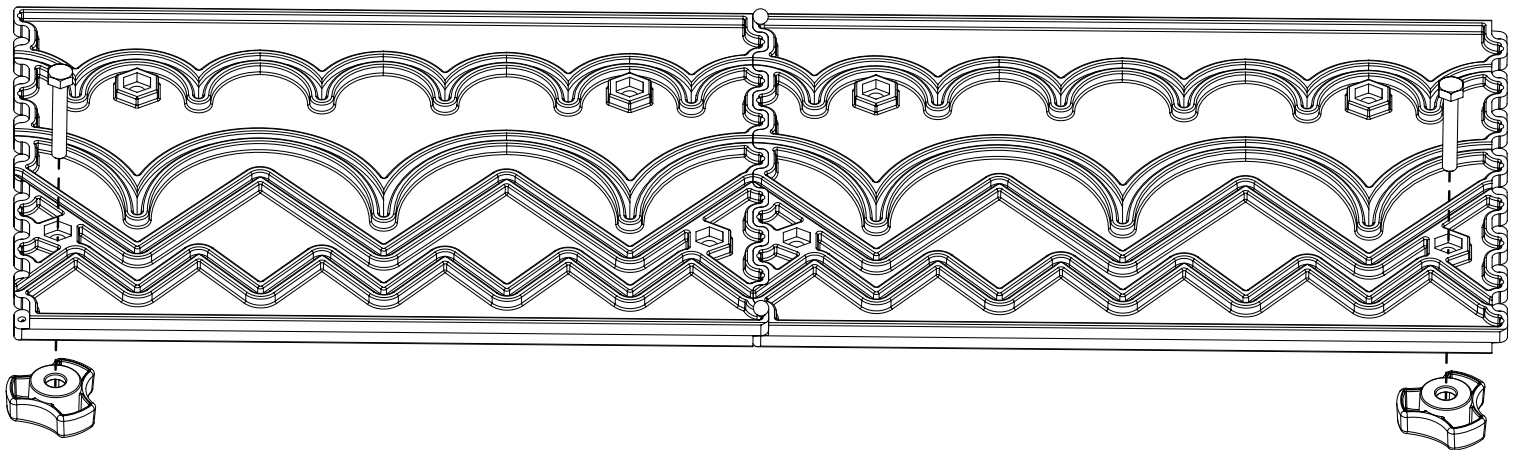

**1-6** Place plastic knob onto the end of the bolt and hand tighten completely

## Step 2A: Pattern Perfect Stylus Bracket Assembly (Metal carriage)

Parts Needed: 1-Stylus Bracket  
2-M6 x 55 Socket Head Cap Screw  
2-M6 Hex Nut

**2A-1** Remove your machine from the top carriage allowing you to more easily install the stylus bracket.

**2A-2** Take your top carriage off the frame and turn it upside down. Place two M6 x 55 Cap Screws through each hole in the Stylus Bracket and the top carriage plate. (The Stylus Bracket can be attached on either the left or right side of the carriage).

**2A-3** Next completely tighten the M6 Hex Nuts onto the ends of each bolt.

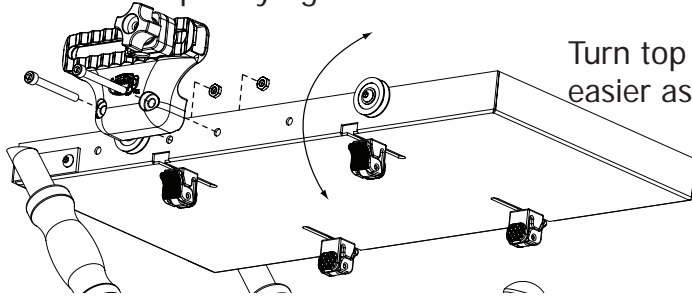

Turn top plate upside-down for easier assembly

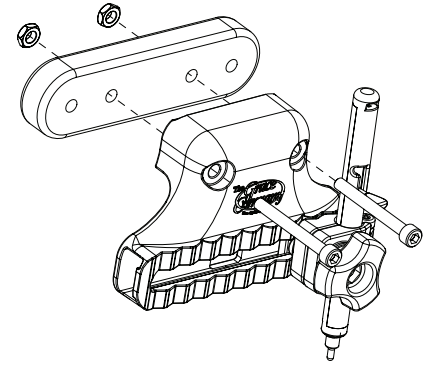

## Step 2B: Pattern Perfect Stylus Bracket Assembly (Wood carriage)

Parts Needed, in addition to those listed in step 2A:

1-Stylus Adaptor  
1-Stylus Adaptor Disk  
2-1/4" x 45 Connector bolt  
2-1/4" Jam Nut

**2B-1** first secure the stylus adaptor to the stylus bracket, using 2- M6 X 55mm socket head cap screws, and 2- M6 hex nuts.

**2B-2** Remove the connector bolt closest to the middle from the handle that is on the side of the carriage that you will be mounting the stylus bracket.

**2B-3** Now secure the stylus adaptor to the top plate by inserting both 45mm connector bolts through the outer holes in the stylus adaptor.

**2B-4** Next place the stylus adaptor disk onto the bolt that will be furthest from the carriage handles.

**2B-5** Insert the bolts through the holes in the top plate, and secure into place using the provided 1/4" jam nuts.

## Step 3: Stylus to Stylus Bracket Assembly

Parts Needed: 1-Stylus  
1-Stylus Bracket Assembly with Top Carriage

**3-1** First loosen the Plastic Knob on your Stylus Attachment, slide the stylus down into the stylus holder (as show right), and tighten the Plastic Knob.

### User Tips:

• You can create different pattern designs/combinations by offsetting individual templates. Combine patterns from either side of the templates (see example #1), or stagger the templates to line up different from the same or different sides (see example #2).

### Example #1

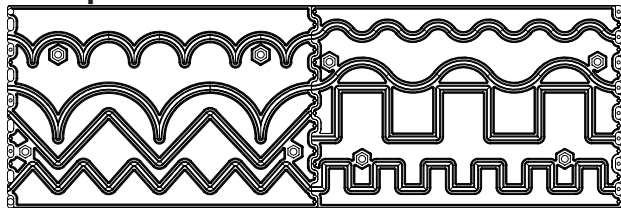

### Example #2

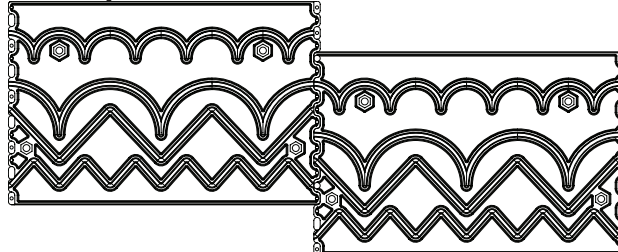

• You can also index the Stylus in 1/2 inch increments, which allows you to offset patterns on your quilt or switch to different patterns on the templates.

(See reverse for examples of offset patterns)

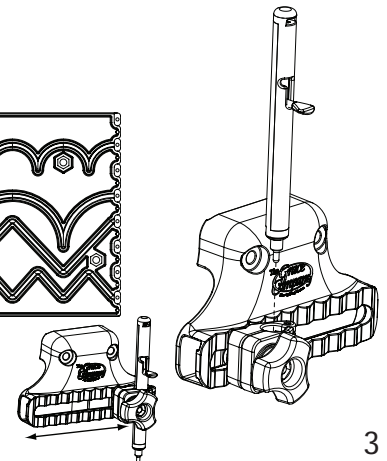



# Template Guide Example Patterns

Each pattern is created using the same principles. By moving the stylus forward or back and the template right or left incrementally at the beginning of each pass, numerous different patterns can be created. Combining series of combinations of the designs can also create an infinite number of different patterns.

## 4 Inch Scallop

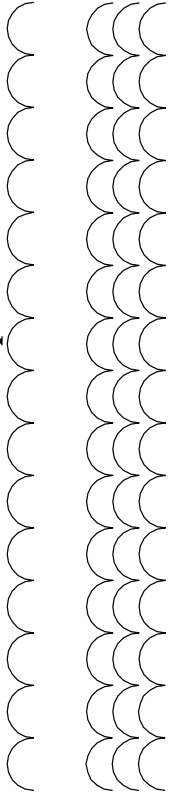

1. Begin at the left side of your quilt with the stylus as far forward as possible.
2. Next move the stylus 2" (4 notches) back and begin tracing the pattern moving left (This will move the machine 2" forward where you will begin sewing)
3. Repeat the last step when you reach the left side of the pattern.
4. When you finish the third step and have arrived at the right side of the pattern again, reset the stylus to the starting position and begin the process over again, this time beginning from the right side of the quilt.

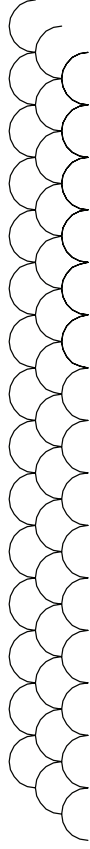

This pattern is created by moving the stylus back 2" (4 notches) and shifting the template over 2" after each pass.

## 4 Inch VPattern

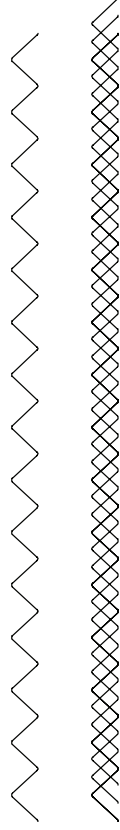

This pattern is created by shifting the template to 1" after each pass.

## 4 Inch Bump

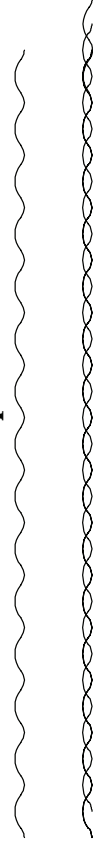

This pattern is created by shifting the template 2" after each pass.



This pattern is created by moving the stylus 2" (4 notches) and shifting the template over 2" after each pass.

## Large & Small Scallop Combination



To create this pattern begin both patterns at the same point. Then repeat the previous step 2" forward from the starting point.

## Small Bump & Large V Combination

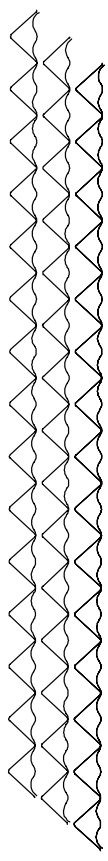

To create this pattern begin both patterns at the same point. Then repeat the previous step 2" forward and 2" from the starting point.

## Small V & Small Scallop V Combination

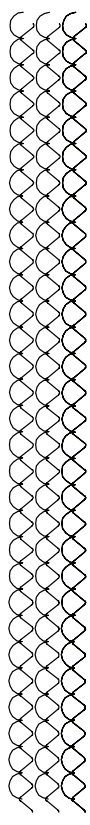

To create this pattern begin the scallop pattern 1" forward and 1" from the starting point of the small V pattern. Then repeat the previous step 2" forward from the starting point.

## Large Scallop & Large Bump Reversed Combination

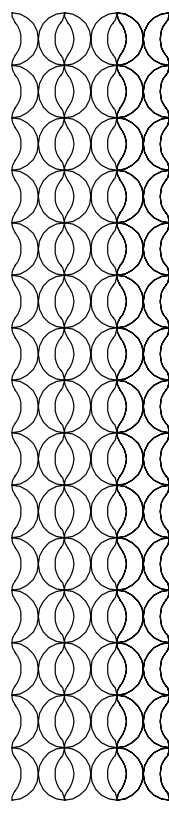

To create this pattern begin the patterns at the same point. Rotate the pattern and repeat the the two patterns beginning 4" forward from the start point. Continue by repeating the previous steps.

## Large Scallop Reversed Combination

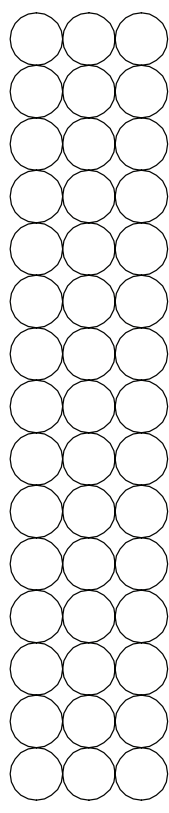

To create this pattern begin the first and second pass at the same point. Rotate the pattern for the second pass. Repeat the previous steps beginning 4" inches forward from the start point of the first pass.